



SPECIFICATION FOR APPROVAL

1/3W, 1206, Low Resistance Chip Resistor (Lead free / Halogen Free)

1. Scope

This specification applies to 3.2mm x 1.6mm size 1/3W, fixed thick film low resistance value chip resistors rectangular type.

2. Type Designation

RLT1632 - F -

(1) (2) (3) (4)

Where (1) Size No.

(2) Power Rating:

$$F = 1/3W$$

(3) Resistance value: Refer to paragraph 4-1

For example --

Four digits of number

$$R100 = 0.1\Omega$$

$$1R00 = 1.0\Omega$$

The "R" shall be used as a decimal point

(4) Resistance tolerance:

$$F = \pm 1.0\%, G = \pm 2\%, J = \pm 5\%$$

3. Outline Dimensions

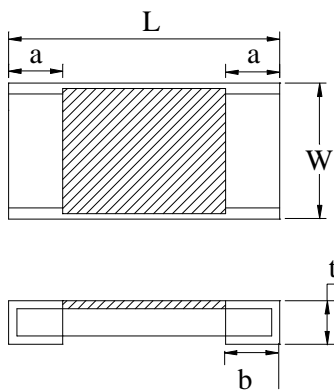

Code Letter	Dimension
L	3.20 ± 0.20
W	1.60 ± 0.20
t	0.60 ± 0.10
a	0.50 ± 0.25
b	0.50 ± 0.25

Unit : mm



SPECIFICATION FOR APPROVAL

4. Ratings

4-1 Specification

Table 1

Power Rating*	1/3 W	
Resistance Tolerance	1%(F), 2%(G), 5%(J)	
Resistance Range	0.05Ω ~ <0.1Ω	0.1Ω ~ <10Ω
Temperature Coefficient of Resistance(ppm/°C)	0 ~ +250	0 ~ +200

Note*:

Power Rating is based on continuous full load operation at rated ambient temperature of 70°C.

For resistor operated at ambient temperature in excess of 70°C, the maximum load

shall be derated in accordance with the following curve.

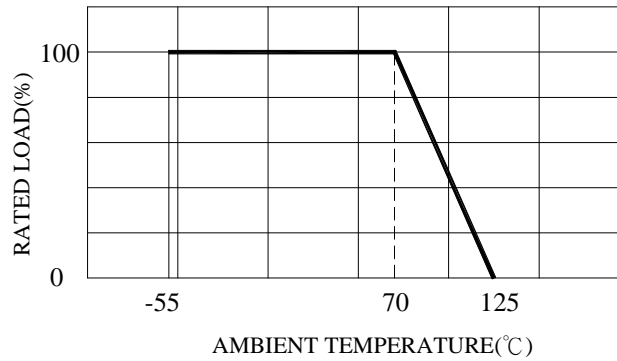

4-2 Rated Voltage

The d.c. or a.c. r.m.s. voltage shall be calculated from the following expression

$$V = \sqrt{P \times R}$$

Where V : Rated voltage (V)

P : Rated power (W)

R : Nominal resistance (Ω)

4-3 Operating and Storage Temperature Range

-55 to +125°C

SPECIFICATION FOR APPROVAL

5. Marking

Each Resistor is marked with 4 digits code on the protective coating to designate to the nominal resistance value.

$0.05 \leq R < 10\Omega$, Marking 4 digits

EX) $0.05\Omega \rightarrow$ R050 , $0.1\Omega \rightarrow$ R100

$4.7\Omega \rightarrow$ 4R70 , $10\Omega \rightarrow$ 10R0

6. Characteristics

6-1 Electrical

Item	Specification and Requirement	Test Method (JIS 5201)
Temperature Coefficient of Resistance(ppm/°C)	As follow table 1.	Room temperature Room temperature +100°C
Short Time Overload	$\Delta R: \pm 1.0\%$ Without damage by flashover, spark, arcing, burning or breakdown	(1) Applied voltage: 2.5 x rated voltage (2) Test time: 5 seconds
Insulation Resistance	Over 100 M Ω on Overcoat layer face up Over 1,000 M Ω on Substrate side face up	(1) Setup as figure 1 (2) Test voltage: 100V _{DC} ±15V _{DC} (3) Test time: 60 + 10 / - 0 seconds
Voltage Proof	Resistance range:±1.0% Without damage by flashover, spark, arcing, burning or breakdown	(1) Setup as figure 1 (2) Test voltage: 400V _{AC} (rms.) (3) Test time: 60 + 10 / - 0 seconds

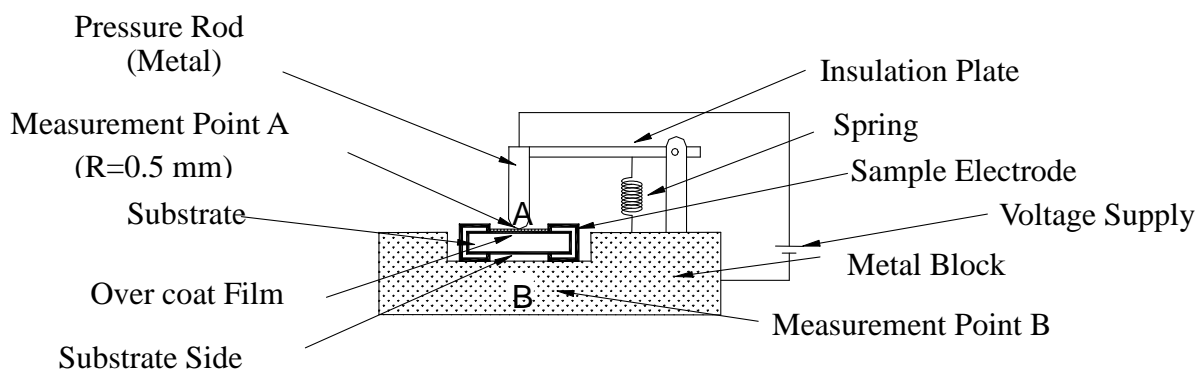

Figure 1 : Measurement Setup

**SPECIFICATION FOR APPROVAL**

6-2 Mechanical

Item	Specification and Requirement	Test Method (JIS 5201)
Solderability	The surface of terminal immersed shall be minimum of 95% covered with a new coating of solder	Solder bath: After immersing in flux, dip in $245 \pm 5^{\circ}\text{C}$ molten solder bath for 2 ± 0.5 seconds
Resistance to Solder Heat	$\Delta R: \pm 1.0\%$ Without distinct deformation in appearance	(1) Pre-heat: $100\sim 110^{\circ}\text{C}$ for 30 seconds (2) Immersed at solder bath of $270 \pm 5^{\circ}\text{C}$ for 10 ± 1 seconds (3) Measuring resistance 1 hour after test
Bending Test	$\Delta R: \pm 1.0\%$ Without mechanical damage such as break	Bending value: 3 mm for 30 ± 1 seconds
Solvent Resistance	Without mechanical and distinct damage in appearance	(1) Solvent: Trichloroethane or Isopropyl alcohol (2) Immersed in solvent at room temperature for 300 seconds



SPECIFICATION FOR APPROVAL

6-3 Endurance

Item	Specification and Requirement	Test Method (JIS 5201)
Rapid Change of Temperature	△ R:±1.0% Without distinct damage in appearance	(1) Repeat 5 cycle as follow: (-55 ± 3°C,30minutes) →(Room temperature, 2~3 minutes) →(+125 ± 2°C,30minutes) →(Room temperature 2~3 minutes) (2) Measuring resistance 1 hour after test
Moisture with Load	△ R: ±5.0% Without distinct damage in appearance	(1) Environment condition: 40 ± 2°C,90~95% RH (2) Applied Voltage: rated voltage (3) Test period: (1.5 hour ON) →(0.5 hour OFF) cycled for total 1,000 + 48 / - 0 hours (4) Measuring resistance 1 hour after test
Load Life	△ R: ±5.0% Without distinct damage in appearance	(1) Test temperature: 70 ± 3°C (2) Applied Voltage: rated voltage (3) Test period: (1.5 hour ON) →(0.5 hour OFF) cycled for total 1,000 + 48 / - 0 hours (4) Measuring resistance 1 hour after test
Low Temperature Store	△ R: ± 5.0% Without distinct damage in appearance	(1) Store temperature: -55 ± 3°C for total 1,000 + 48 / - 0 hours (2) Measuring resistance 1 hour after test
High Temperature Store	△ R: ± 5.0% Without distinct damage in appearance	(1) Store temperature: +125 ± 2°C for total 1,000 + 48 / - 0 hours (2) Measuring resistance 1 hour after test

SPECIFICATION FOR APPROVAL

7. Recommend Land Pattern Dimensions

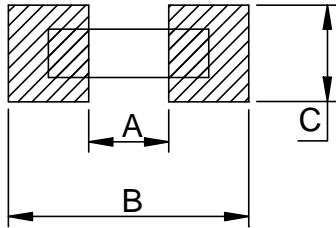

A	2.2~2.6
B	4.4~4.8
C	1.8~2.4

Unit : mm

8. Construction Drawing

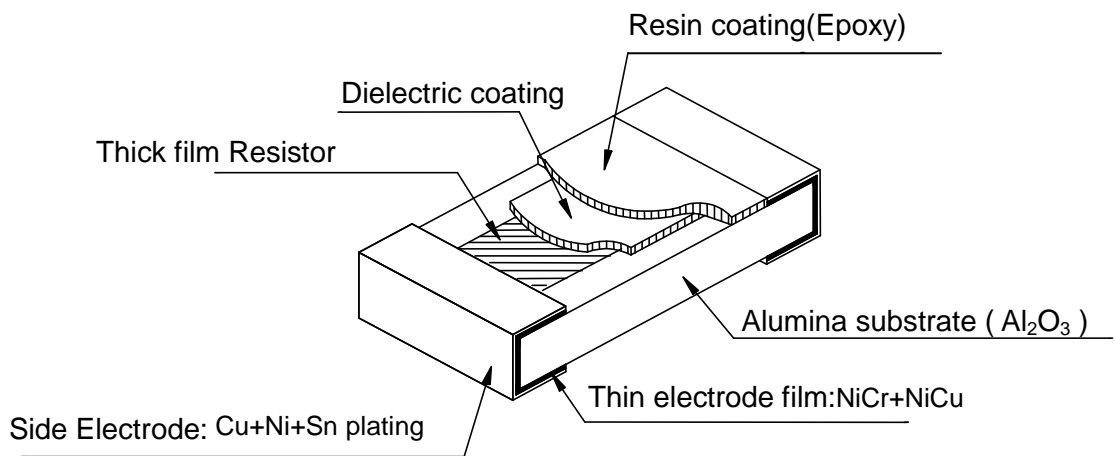



SPECIFICATION FOR APPROVAL

9. Packaging

9-1 Dimensions

9-1-1 Tape packaging dimensions

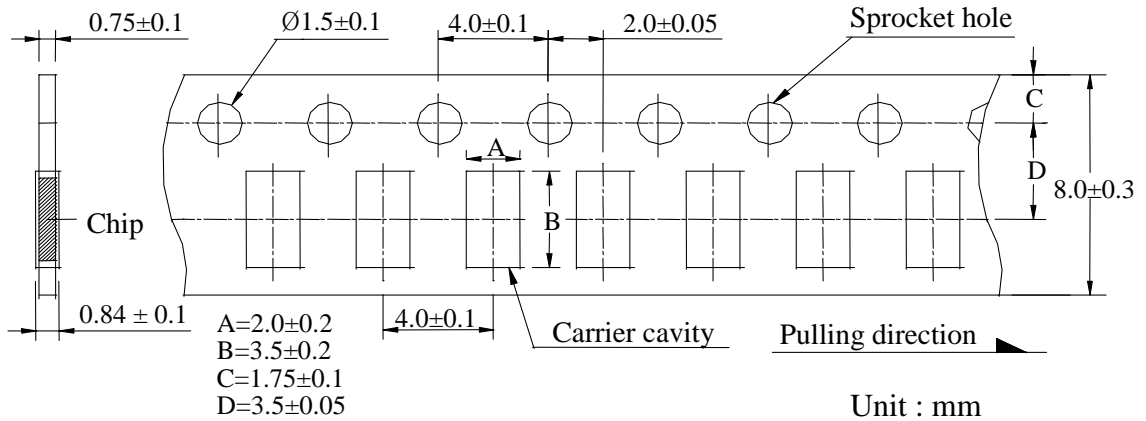

Remark: Leader tape length ≥ 30 cm(150 Hollow carrier cavity)

9-1-2 Reel dimensions

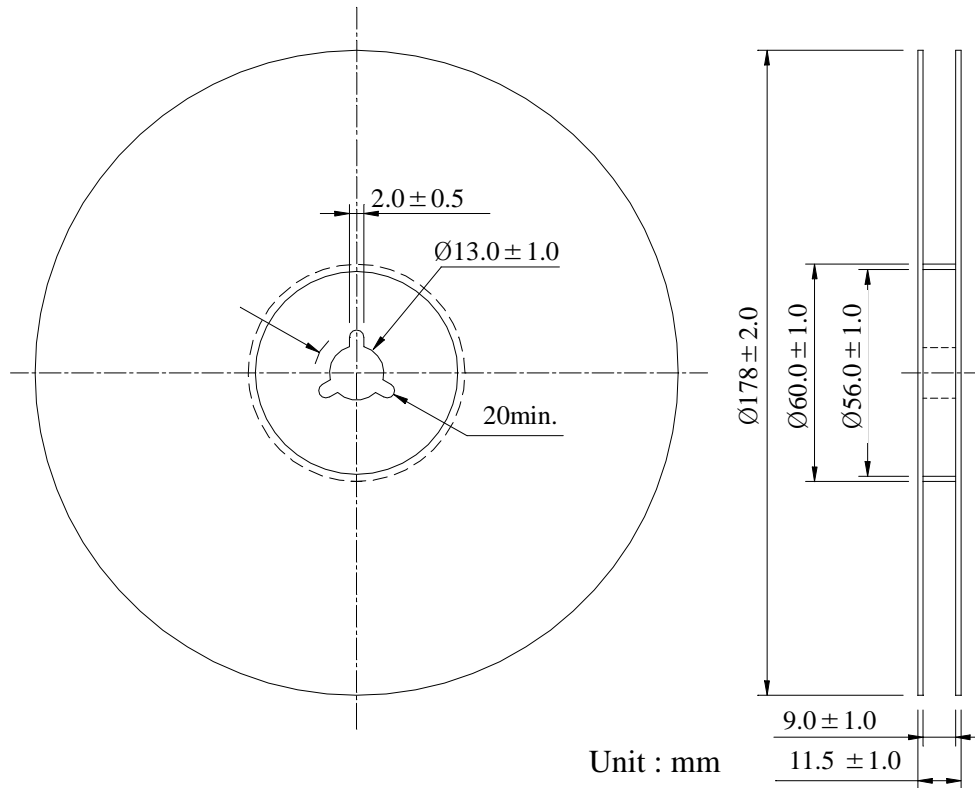



SPECIFICATION FOR APPROVAL

9-2 Peel force of top cover tape

The peel speed shall be about 300 mm/min.

The peel force of top cover tape shall be between 0.1 to 0.7 N.

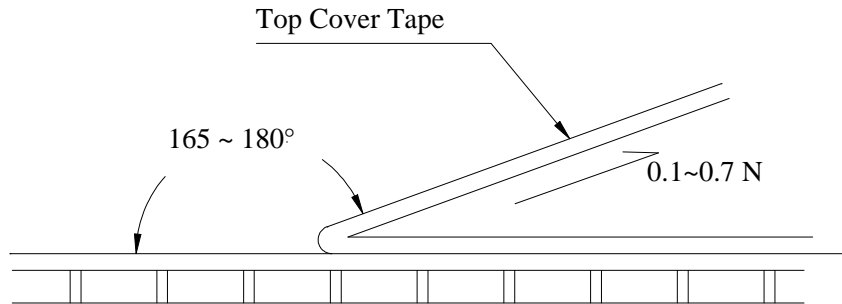

9-3 Numbers of taping 5,000 pieces /reel

9-4 Label making

The following items shall be marked on the reel.

- (1) Type designation.
- (2) Quantity
- (3) Manufacturing date code
- (4) Manufacturer's name



SPECIFICATION FOR APPROVAL

10. Carenote

10-1 Care note for storage

- (1) Chip resistor shall be stored in a room where temperature and humidity must be controlled. (temperature 5 to 35°C , humidity 45 to 85% RH) However, a humidity keep it low, as it is possible.
- (2) Chip resistor shall be stored as direct sunshine doesn't hit on it.
- (3) Chip resistor shall be stored with no moisture, dust, a material that will make solderability inferior, and a harmful gas (Chloridation hydrogen, sulfurous acid gas, and sulfuration hydrogen)

10-2 Carenote for operating and handling

- (1) It is necessary to protect the edge and protection coat of resistors from mechanical stress.
- (2) Handle with care when printing circuit board (PCB) is divided or fixed on support body, because bending of printing circuit board (PCB) mounting will make mechanical stress for resistors.
- (3) Resistors shall be used with in rated range shown in specification. Especially, if voltage more than specified value will be loaded to resistor, there is a case it will make damage for machine because of temperature rise depending on generating of heat, and increase resistance value or breaks.
- (4) In case that resistor is loaded a rated voltage, it is necessary to confirms temperature of a resistor and to reduce a load power according to load reduction curve, because a temperature rise of a resistor depends on influence of heat from mounting density and neighboring element.
- (5) Observe Limiting element voltage and maximum overload voltage specified in each specification
- (6) If there is possibility that a large voltage (pulse voltage, shock voltage) charge to resistor, it is necessary that operating condition shall be set up before use.