



Photo is for reference only

Input voltage: 36~75V
 Single output: 12V
 Output current: 67A

FEATURES

Electrical

- Typical Efficiency up to 96.3% at 50% load
- PMBus communication
- Fully regulated output voltage
- Fully protected: Input UVP, output OVP, OCP and OTP
- Remote ON/OFF
- Monotonic and Pre-bias startup
- No minimum load required
- 2250Vdc isolation

Mechanical

- Size: 58.4x36.83x12.7mm (2.30"x1.45"x0.50")

Safety & Certificate

- IEC/EN/UL/CSA 62368-1, 2nd edition
- ISO 9001, TL 9000, ISO 14001, QS 9000,
- OHSAS18001 certified manufacturing facility

SOLDERING METHOD

- Wave soldering
- Hand soldering

APPLICATIONS

- Datacom / Networking
- Wireless Networks
- Optical Network Equipment
- Server and Data Storage
- Industrial / Testing Equipment

Recommended Part Number

Model Name	Input		Output		Eff. @ 50% Load	Others
Q48SK12067NNDH	36V~75V	24A	12V	67A	96.3% @48Vin	With PMBus
Q48SK12067PNDH	36V~75V	24A	12V	67A	96.3% @48Vin	With PMBus
Q48SK12067PNDN	36V~75V	24A	12V	67A	96.3% @48Vin	With PMBus
Q48SK12067NCIH	36V~75V	24A	12V	67A	96.3% @48Vin	Without PMBus
Q48SK12067NRAH	36V~75V	24A	12V	67A	96.3% @48Vin	Without PMBus
Q48SK12067NRDH	36V~75V	24A	12V	67A	96.3% @48Vin	With PMBus

Part Numbering System

Q	48	S	K	120	67	N	N	D ^{note}	H
Form Factor	Input Voltage	Number Of Outputs	Product Series	Output Voltage	Output current	ON/OFF Logic	Pin Length	Pin Assignment	Option Code
Q - Quarter Brick	48 - 36~75V	S - Single	K - Series Number	120 - 12.0V	67 - 67A	N - Negative P - Positive	R - 0.170" N - 0.145" C - 0.180"	D - Digital pins A - Analog pins I - IBC pins	H - With baseplates

Note:

1. A - Analog pins: without digital pins(pin9~15)
2. D - Digital pins: with digital pins(pin9~15)
3. I - IBC pins*: without digital pins & sense & trim pins

($T_A=25^\circ\text{C}$, airflow rate=300 LFM, $V_{in}=48\text{Vdc}$, nominal V_{out} unless otherwise noted.)

PARAMETER	NOTES and CONDITIONS	Q48SK12067			
		Min.	Typ.	Max.	Units
ABSOLUTE MAXIMUM RATINGS					
Input Voltage					
Continuous		0		75	Vdc
Transient	100mS			100	Vdc
Vin step				10	V/ms
Operating Ambient Temperature		-40		85	$^\circ\text{C}$
Operating Module Temperature	Hot Spot Temperature (Refer to Figure 18 for Hot spot's location)	-40		123	$^\circ\text{C}$
Storage Temperature		-55		125	$^\circ\text{C}$
Input/Output Isolation Voltage				2250	Vdc
INPUT CHARACTERISTICS					
Operating Input Voltage		36	48	75	Vdc
Input Under-Voltage Lockout					
Turn-On Voltage Threshold		33		36	Vdc
Turn-Off Voltage Threshold		31		34	Vdc
Lockout Hysteresis Voltage			2		Vdc
Maximum Input Current	Full Load, $36V_{in}$			24	A
No-Load Input Current	$V_{in}=48\text{V}$, $I_o=0\text{A}$		120		mA
Off Converter Input Current	$V_{in}=48\text{V}$		20		mA
Inrush Current	With 100uF Aluminum Capacitor			1	A ² S
Internal Input Ripple Current	$V_{in}=48\text{V}$, $I_o=67\text{A}$, P-P thru 12uH inductor		1		Arms
Input Voltage Rejection	At 120Hz		-40		dB
OUTPUT CHARACTERISTICS					
Output Voltage Set Point	$V_{in}=48\text{V}$, $I_o=\text{Open Load}$, $T_c=25^\circ\text{C}$	11.88	12	12.12	Vdc
Output Regulation					
Load Regulation	$V_{in}=48\text{V}$, $I_o=I_{o\text{min}}$ to $I_{o\text{max}}$		120		mV
Line Regulation	$V_{in}=36\text{V}$ to 75V , $I_o=0$		0.5		% $V_{o,\text{set}}$
Temperature Regulation	$T_a=-40^\circ\text{C}$ to 85°C	-1	0	+1	% $V_{o,\text{set}}$
Total Output Voltage Range	Over sample load, 36V-75Vin and temperature	11.64	12	12.36	V
Output Voltage Ripple and Noise	5Hz to 20MHz bandwidth				
Peak-to-Peak	Full Load, $C_o=1000\mu\text{F}$ (80%Oscon+20%MLCC) ,1uF ceramic, 10uF tantalum		120		mV
RMS	Full Load, $C_o=1000\mu\text{F}$ (80%Oscon+20%MLCC) ,1uF ceramic, 10uF tantalum		20		mV
Operating Output Current Range	36V-75Vin	0		67	A
Output Over Current Protection(latch mode)	when $V_o<10\%V_{o,\text{nom}}$,	73		100	A
Output Over Voltage Protection(latch mode)			15.2		V
Output voltage trim range		9.6		13.2	V
DYNAMIC CHARACTERISTICS					
Output Voltage Current Transient	$C_o=1000\mu\text{F}$ (80% Oscon+20%MLCC), 1uF ceramic, 10uF tantalum , 2.5A/us				
Positive Step Change in Output Current	75% $I_{o,\text{max}}$ to 50% $I_{o,\text{max}}$		240		mV
Negative Step Change in Output Current	50% $I_{o,\text{max}}$ to 75% $I_{o,\text{max}}$		-240		mV
Settling Time (within 1% nominal V_{out})			200		us
Turn-On Delay Time					
Start-Up Delay Time From Input Voltage	On/Off=On, from $V_{in}=\text{Turn-on Threshold}$ to $V_o=10\%V_{o,\text{nom}}$		35		mS
Start-Up Delay Time From On/Off Control	$V_{in}=V_{in,\text{nom}}$, from On/Off=On to $V_o=10\%V_{o,\text{nom}}$		20		mS
Output Voltage Rise Time	$V_o=10\%$ to $90\%V_{o,\text{nom}}$		16		mS
Output Capacitance Range	20% ceramic, 80% Oscon or AL	1000		20000	uF
EFFICIENCY					
100% Load	$V_{in}=48\text{V}$, $I_o=\text{Full Load}$, $T_c=25^\circ\text{C}$		95.8		%
50% Load	$V_{in}=48\text{V}$, $I_o=\text{Half Load}$, $T_c=25^\circ\text{C}$		96.3		%
ISOLATION CHARACTERISTICS					
Input to Output Isolation Capacitance			4.7		nF
FEATURE CHARACTERISTICS					
Switching Frequency			160		kHz
On/Off Control, Negative Remote On/Off logic					
Logic Low (Module On)	$V_{on/off}$	0		0.7	V
Logic High (Module Off)	$V_{on/off}$	3.5		10	V
ON/OFF Current	$I_{on/off}$ at $V_{on/off}=0.0\text{V}$			1.5	mA
Leakage Current	Logic High, $V_{on/off}=5\text{V}$		1		mA
On/off pin open circuit voltage			4.5		V
GENERAL SPECIFICATIONS					
MTBF	$I_o=80\%$ of $I_{o,\text{max}}$, $T_a=25^\circ\text{C}$		4.2		Mhours
Weight	With heat-spreader		78		grams
Over-Temperature Shutdown (With heat-spreader)	Refer to Figure 18 for Hot spot 1 location (48Vin,80% I_o , 200LFM,Airflow from V_{in+} to V_{in-})		133		$^\circ\text{C}$
Over-Temperature Shutdown (With 0.27" height heat sink)	Refer to Figure 20 for Hot spot 2 location (48Vin,80% I_o , 200LFM,Airflow from V_{in+} to V_{in-})		133		$^\circ\text{C}$
Over-Temperature Shutdown (With 0.5" height heat sink QTL050A)	Refer to Figure 22 for Hot spot 3 location (48Vin,80% I_o , 200LFM,Airflow from V_{in+} to V_{in-})		133		$^\circ\text{C}$
Over-Temperature Shutdown (Heat spreader is attached to cold plate)	Refer to Figure 25 for Hot spot 4 location (48Vin,80% I_o ,No airflow, Water cooling)		133		$^\circ\text{C}$
Over-Temperature Shutdown (NTC resistor)			130		$^\circ\text{C}$
Note1: Please attach thermocouple on NTC resistor to test OTP function, the hot spots' temperature is just for reference.					

PARAMETER	NOTES and CONDITIONS	Min.	Typ.	Max.	Units
PMBUS SIGNAL INTERFACE CHARACTERISTICS					
Logic Input Low (V _{IL})	Data, SMBAlert, Clock pin	0		0.8	V
Logic Input High (V _{IH})	Data, SMBAlert, Clock pin	2.4		3.6	V
Logic Output Low (V _{OL})	Data, SMBAlert, Clock pin; IOL=4mA			0.4	V
Logic Output High (V _{OH})	Data, SMBAlert, Clock pin; IOH=-4mA	2.5			V
PMBus Operating Frequency Range		100		400	KHz
PMBUS MONITORING CHARACTERISTICS					
Output Current Reading Accuracy	V _{in} =48V, I _o =50% ~ 100% of I _o , max;		5		%
Output Current Reading Accuracy	V _{in} =48V, I _o =0% ~ 50% of I _o , max;		5		%
Output Voltage Reading Accuracy		-3		+3	%
Input Voltage Reading Accuracy			3		%
Temperature Reading Accuracy		-5		+5	°C
Input Power Reading Accuracy			10		%

Typical Application Schematic

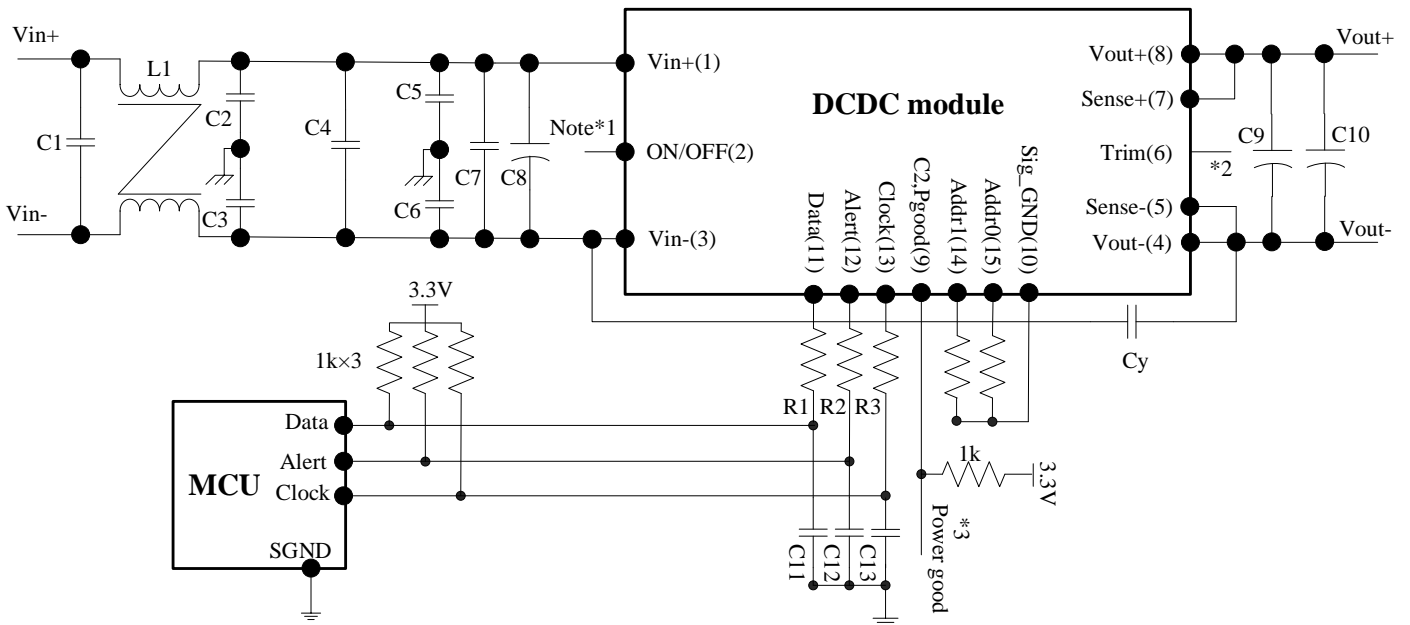

***Note:**

1. Refer to page11 for the On/off(pin2) implementation.
2. Refer to page11 for the Trim(pin6) implementation.
3. Refer to page11 for C2/Pgood pin implementation.
4. Refer to page15 for ADDR (pin14-15) implementation.
5. R1/R2/R3/C11/C12/C13 value are 49.9ohm/49.9ohm/49.9ohm /100p/100p/100p, and should be close to brick in application.

Location	Vendor P/N	Description	Qty	Vendor	Purpose
C8	80SXE47M	CAP AL SP 80V 47uF M 10*13 P5	1	MATSUSHITA	For stable operation
C9	RBS1C471MCS1KX	CAP AL SP 16V 470uF M 8*11.5 TP P	2	NICHICON	
C10	C4532X5R1C336MT	CAP MC SMD 16V 33uF M X5R 1812	6	TDK	
C1	C3216X7R2A105KT5	CAP MC SMD 100V 1uF K X7R 1206 OPEN	1	TDK	For EMC
C2	C3216X7R2A105KT5	CAP MC SMD 100V 1uF K X7R 1206 OPEN	1	TDK	
C3	CS17-F2GA103MYVS	CAP Y2/X1 CD 250VAC 0.01uF M F TP VI10	1	TDK	
C4	C3216X7R2A105KT5	CAP MC SMD 100V 1uF K X7R 1206 OPEN	1	TDK	
C5	MKP-104K0257AB107S-P	CAP X2 MP PC 275VAC 0.1uF K S7.5	1	HUA JUNG	
C6	MKP-104K0257AB107S-P	CAP X2 MP PC 275VAC 0.1uF K S7.5	1	HUA JUNG	
C7	UBT2A101MHD	CAP AL 100V 100uF M 12.5*20 P5	1	NICHICON	
CY	/	/	/	/	
L1	/	1mH	1	/	

*The components for EMC purpose can be deleted if don't need the function.

Mechanical Drawing For Q48SK12067XXDX

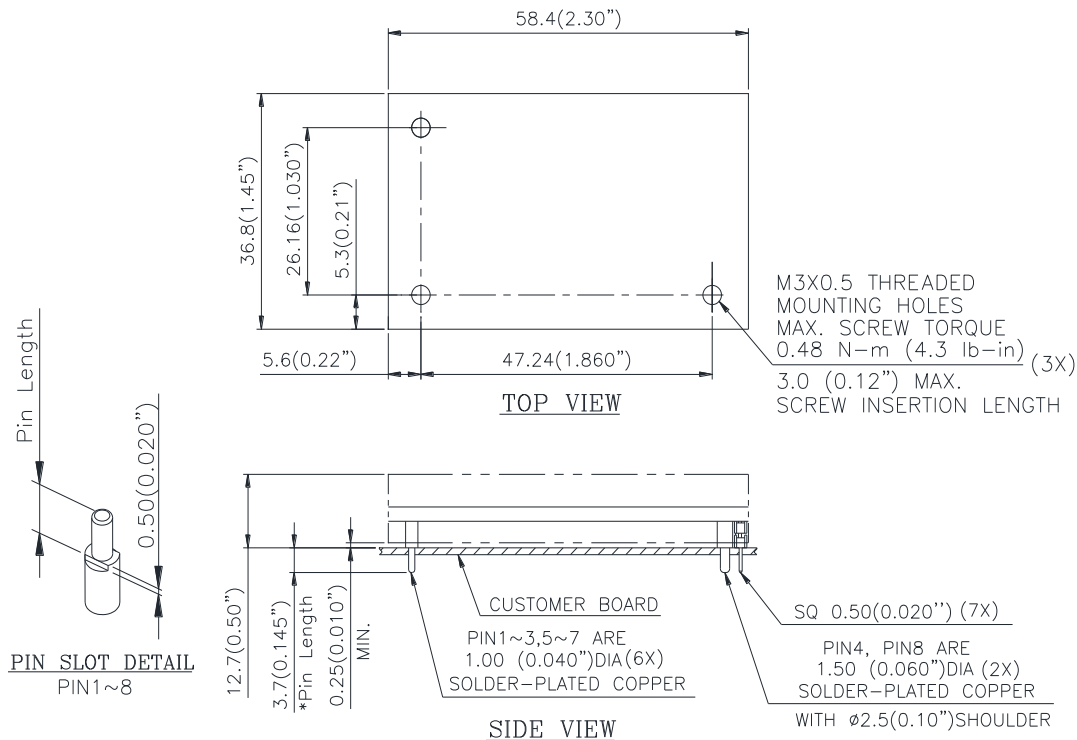

*Standard pin tail length. Optional pin tail lengths shown in PART NUMBERING SYSTEM

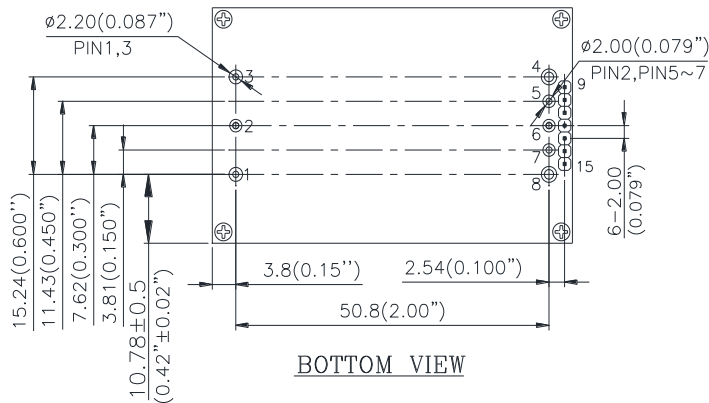

PIN	NAME	OPTIONAL
1	Vin(+)	
2	ON/OFF	
3	Vin(-)	
4	Vout(-)	
5	Sense(-)	YES
6	Trim	YES
7	Sense(+)	YES
8	Vout(+)	
9	C2	
10	SIG_DGND	
11	DATA	
12	SMBAlert	
13	CLK	
14	ADDR1	
15	ADDR0	

NOTES:
 DIMENSIONS ARE IN MILLIMETERS AND (INCHES)
 TOLERANCES: X.Xmm ± 0.5 mm(X.XX in. ± 0.02 in.)
 X.XXmm ± 0.25 mm(X.XXX in. ± 0.010 in.)

Pin Specification:

- Pins 1-3, 5-7: 1.00mm (0.040") diameter (All pins are copper alloy with matte Tin plating over Nickel under plating)
- Pins 4, 8: 1.50mm (0.059") diameter (All pins are copper alloy with matte Tin plating over Nickel under plating)
- Pins 9-15: Digital pins, SQ 0.50mm(0.020") (All pins are copper with gold flash plating)

Mechanical Drawing
For Q48SK12067XXAX
For Q48SK12067XXIX

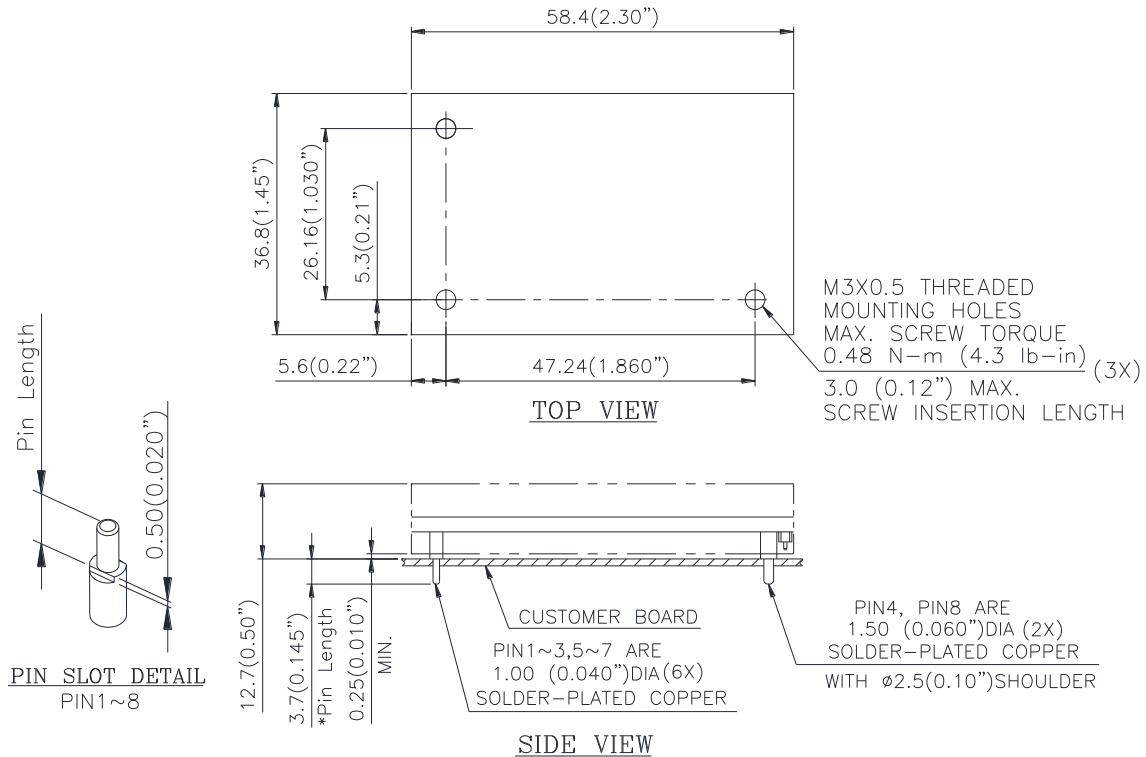

*Standard pin tail length. Optional pin tail lengths shown in PART NUMBERING SYSTEM

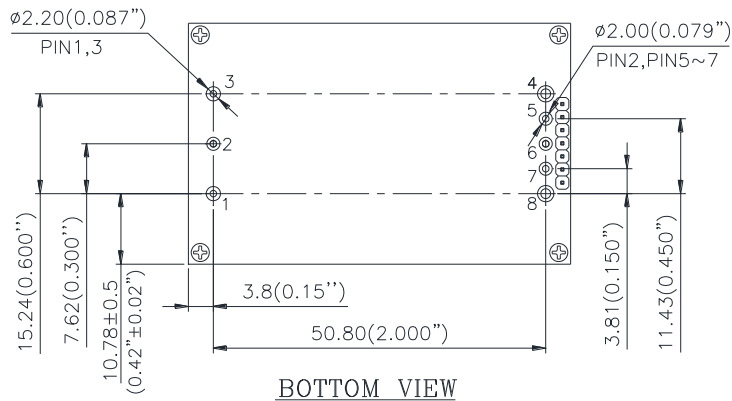

PIN	NAME	OPTIONAL
1	Vin(+)	
2	ON/OFF	
3	Vin(-)	
4	Vout(-)	
5	Sense(-)	YES
6	Trim	YES
7	Sense(+)	YES
8	Vout(+)	

NOTES:
DIMENSIONS ARE IN MILLIMETERS AND (INCHES)
TOLERANCES: X.Xmm \pm 0.5mm(X.XX in. \pm 0.02 in.)
X.XXmm \pm 0.25mm(X.XXX in. \pm 0.010 in.)

Pin Specification:

Pins 1-3,5-7 1.00mm (0.040") diameter (All pins are copper alloy with matte Tin plating over Nickel under plating)
Pins 4,8 1.50mm (0.059") diameter (All pins are copper alloy with matte Tin plating over Nickel under plating)

Suggested Layout For Q48SK12067XXDX

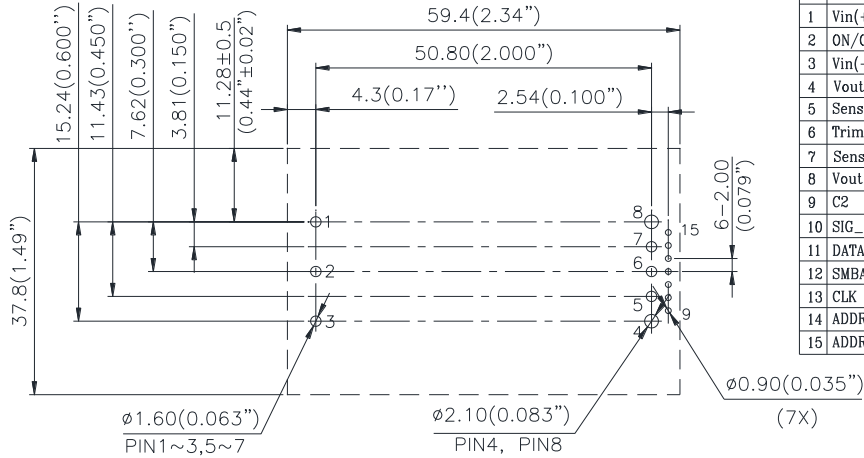

PIN	NAME	OPTIONAL
1	Vin(+)	
2	ON/OFF	
3	Vin(-)	
4	Vout(-)	
5	Sense(-)	YES
6	Trim	YES
7	Sense(+)	YES
8	Vout(+)	
9	C2	
10	SIG_DGND	
11	DATA	
12	SMBAlert	
13	CLK	
14	ADDR1	
15	ADDR0	

NOTES:
DIMENSIONS ARE IN MILLIMETERS AND (INCHES)
TOLERANCES: X.Xmm±0.5mm(X.XX in.±0.02 in.)
X.XXmm±0.25mm(X.XXX in.±0.010 in.)

For Q48SK12067XXAX For Q48SK12067XXIX

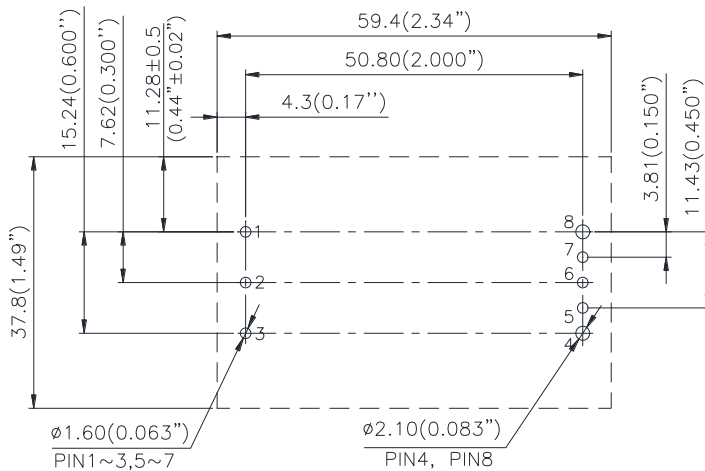

PIN	NAME	OPTIONAL
1	Vin(+)	
2	ON/OFF	
3	Vin(-)	
4	Vout(-)	
5	Sense(-)	YES
6	Trim	YES
7	Sense(+)	YES
8	Vout(+)	

NOTES:
DIMENSIONS ARE IN MILLIMETERS AND (INCHES)
TOLERANCES: X.Xmm±0.5mm(X.XX in.±0.02 in.)
X.XXmm±0.25mm(X.XXX in.±0.010 in.)

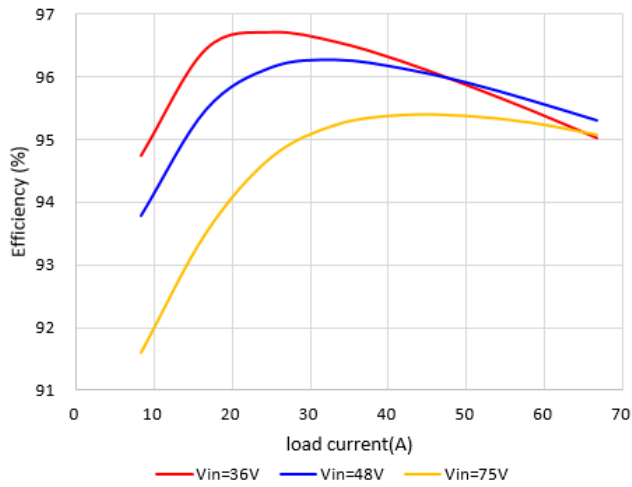

Figure 1: Efficiency vs. load current

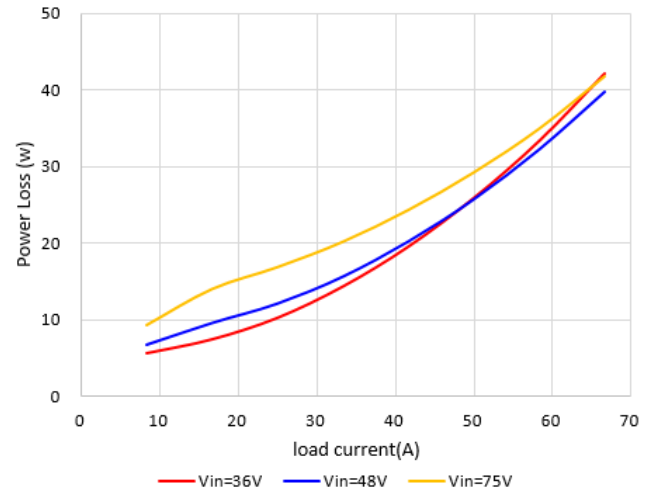

Figure 2: Loss vs. load current

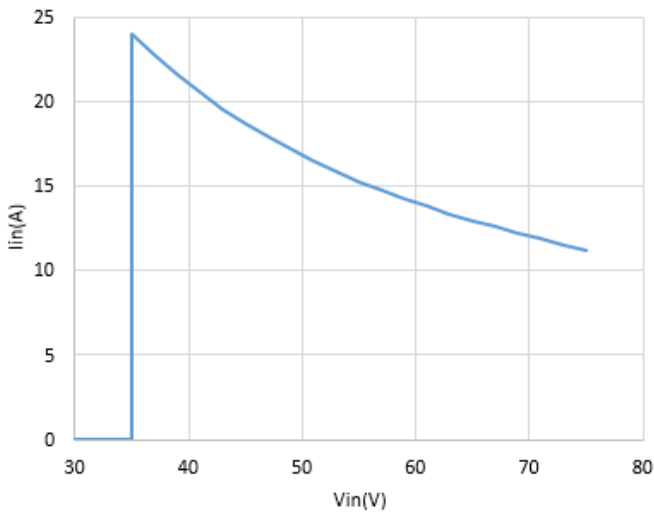

Figure 3: Full Load Input Characteristics

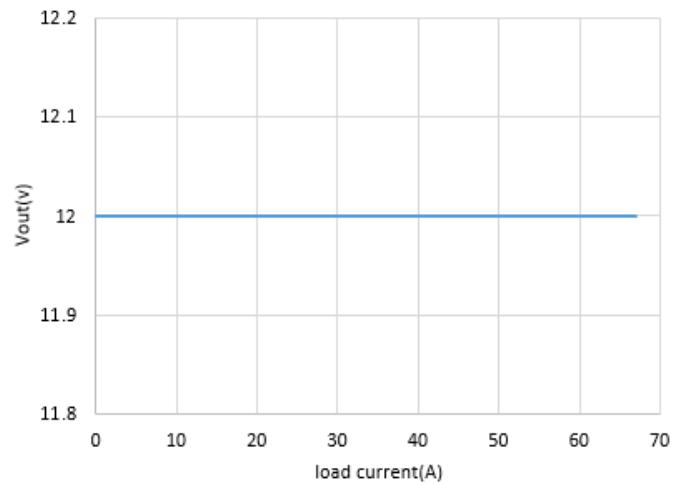

Figure 4: Output voltage vs. load current

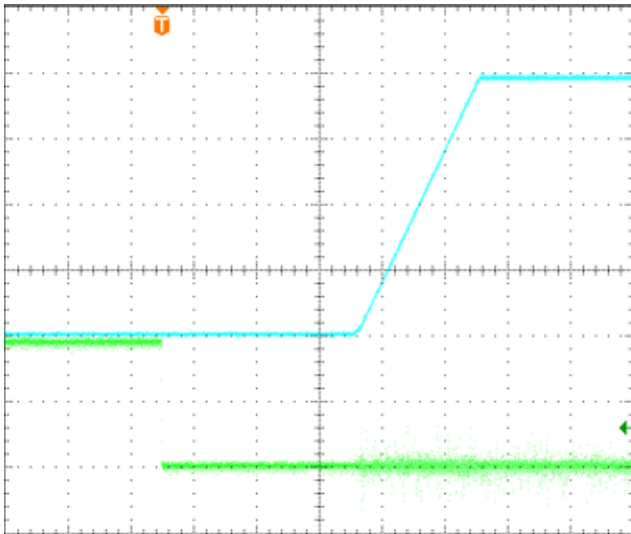

Figure 5: Remote On/off (negative logic) at full load
 $V_{in}=48V$, $I_{out}=67A$, Time: 5ms/div.
 V_{out} (top trace): 3V/div;
 V_{remote} On/Off signal(bottom trace): 2V/div.

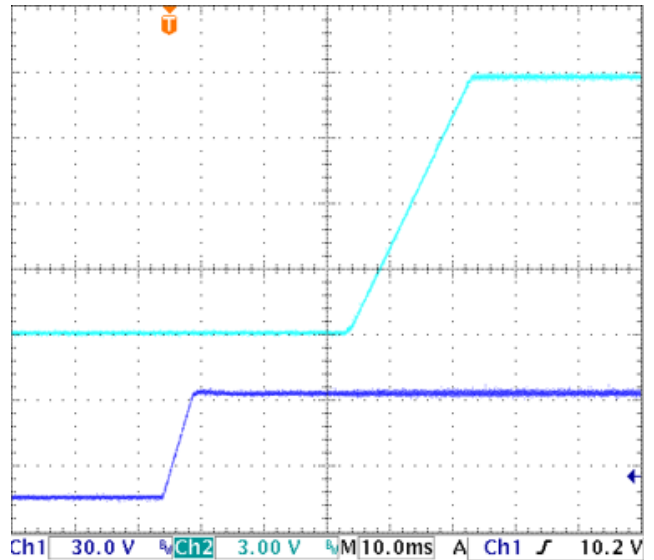

Figure 6: Input Voltage Start-up at full load
 $V_{in}=48V$, $I_{out}=67A$, Time: 10ms/div.
 V_{out} (top trace): 3V/div;
 V_{in} (bottom trace): 30V/div.

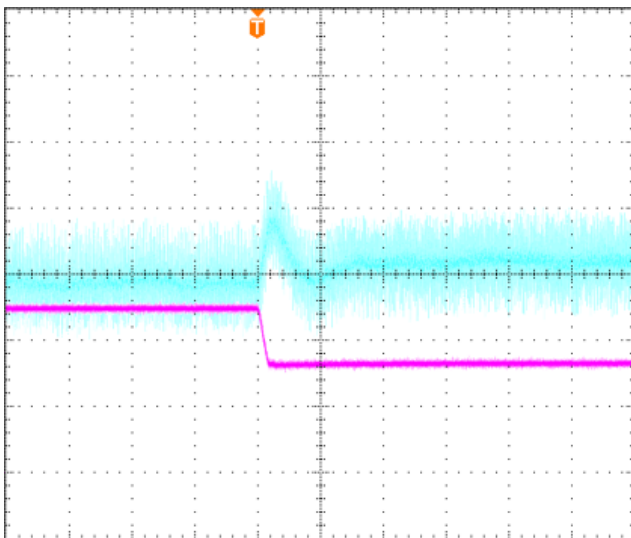

Figure 7: Transient Response
 $(V_{in}=48V, 1A/\mu s$ step change in load from 50% to 75% of $I_{o,max}$)
 V_{out} (top trace): 200mV/div, 100us/div;
 I_{out} (bottom trace): 20A/div.
 Scope measurement should be made using a BNC cable (length shorter than 20 inches). Position the load between 51 mm to 76 mm (2 inches to 3 inches) from the module
 820uF Oscon, 33uF*6 MLCC, 1uF Ceramic, 10uF Tantalum.

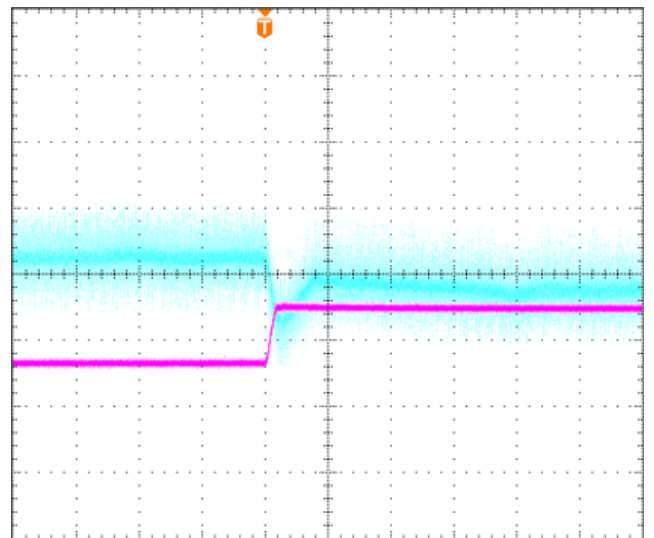

Figure 8: Transient Response
 $(V_{in}=48V, 1A/\mu s$ step change in load from 75% to 50% of $I_{o,max}$)
 V_{out} (top trace): 200mV/div, 100us/div;
 I_{out} (bottom trace): 20A/div.
 Scope measurement should be made using a BNC cable (length shorter than 20 inches). Position the load between 51 mm to 76 mm (2 inches to 3 inches) from the module
 820uF Oscon, 33uF*6 MLCC, 1uF Ceramic, 10uF Tantalum.

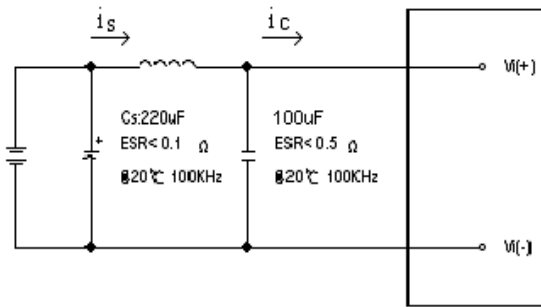

Figure 9: Test Setup Diagram for Input Ripple Current

Note: Measured input reflected-ripple current with a simulated source Inductance of 12µH. Measure current as shown above.

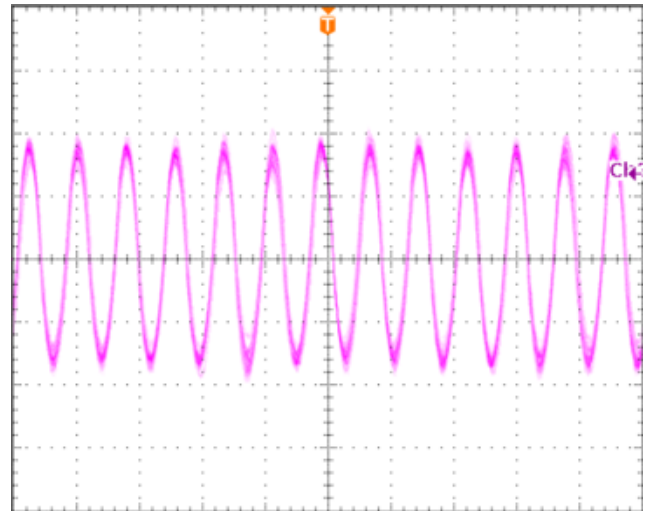

Figure 10: Input Terminal Ripple Current, i_c , at max output current and nominal input voltage with 12µH source impedance and 100µF electrolytic capacitor (1A/div, 4µs/div).

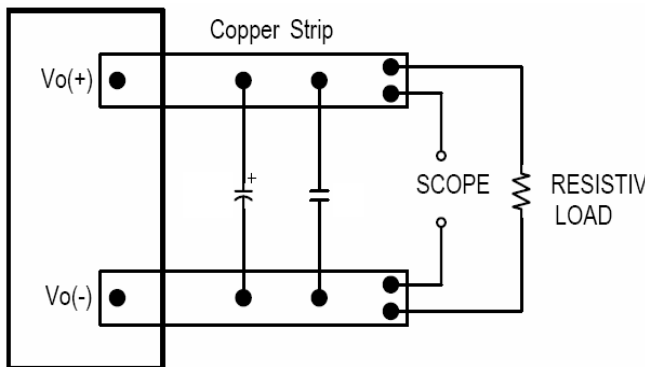
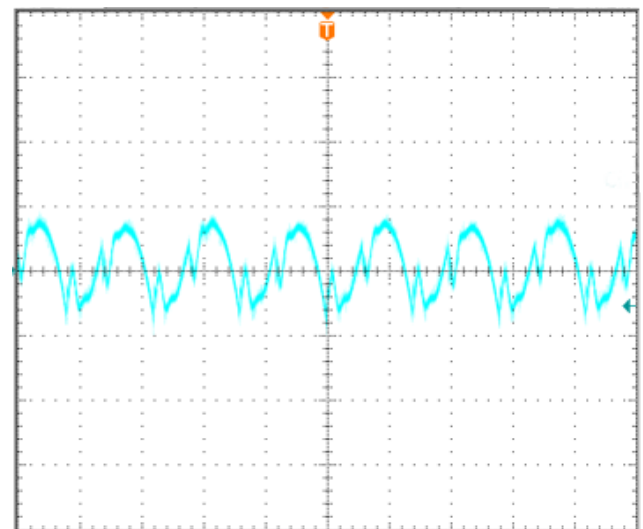

Figure 11: Test Setup for Output Voltage Noise and Ripple



**Figure 12: Output Voltage Ripple and Noise at nominal input voltage and max load current (50 mV/div, 4µs/div)
Load cap: 820µF Oscon, 33µF*6 MLCC, 1µF Ceramic, 10µF Tantalum.
Bandwidth: 20MHz.**

Layout and EMC Considerations

Delta's DC/DC power modules are designed to operate in a wide variety of systems and applications. Below is the reference design for an input filter and tested result which can meet class B in CISPR 22. Refer to page 4 Typical Application schematic.

Test result:

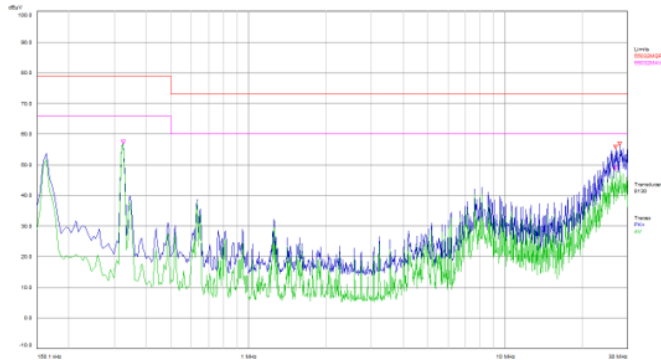

Figure 13: Test Result of EMC (Vin=48V, Io=67A)

Safety Considerations

The power module must be installed in compliance with the spacing and separation requirements of the end-user's safety agency standard, i.e. IEC 62368-1: 2014 (2nd edition), EN 62368-1: 2014 (2nd edition), UL 62368-1, 2nd Edition, 2014-12-01 and CSA C22.2 No. 62368-1-14, 2nd Edition, 2014-12, if the system in which the power module is to be used must meet safety agency requirements.

DC input is considered as ES2, basic safeguard shall be provided between ES2 and MAINS.

The power module has been evaluated and tested in the combination with a supplementary two external fuses in parallel, rated 20A/100Vdc from Littelfuse type 456 series during the safety abnormal test. The need for repeating these tests in the end-use application shall be considered if installed with a higher rated protective device.

This module is not for ordinary person accessible.

This module has basic insulation between input to output with 2250Vdc isolation.

The output is classified as ES1, the need for evaluate end-use application shall be considered if on the system where the module is used, in combination with the module, to ensure that under a single fault, the output voltage does not exceed ES1 limit.

This module is always provided with heat spreader and heat spreader is considered as floating, the additional consideration is required during end-use application where the higher grade of isolation is required.

When installed into a Class II equipment (without grounding), spacing consideration should be given to the end-use installation, as the spacing between the module and mounting surface have not been evaluated.

Over-Current Protection

The modules include an internal output over-current protection circuit, which will endure current limiting for an unlimited duration during output overload. If the output current exceeds the OCP set point, the modules will shut down (hiccup mode). The modules will try to restart after shutdown. If the overload condition still exists, the module will shut down again. This restart trial will continue until the overload condition is corrected.

The modules support to restart three times by default. If the overload condition still exists after three times restart, the modules will disable the output and remain off until the fault is cleared by input voltage repower on, module re-enabled by remote on/off or module re-enabled by PMBUS 0x01 OPERATION command.

The OCP function could be changed via PMBUS. The command related to OCP function are IOUT_OC_WARN_LIMIT, IOUT_OC_FAULT_LIMIT, IOUT_OC_FAULT_RESPONSE, MFR_SLOW_OCP_FAULT_LIMIT, MFR_SLOW_OCP_FAULT_RESPONSE, MFR_IOUT_OC_FAST_FAULT_LIMIT, MFR_IOUT_OC_FAST_FAULT_RESPONSE.

Over-Voltage Protection

The modules include an internal input over-voltage protection circuit, which monitors the voltage on the input terminals. If this voltage exceeds the over-voltage set point, the protection circuit will shut down, and enter latch mode.

The modules will remain off until the fault is cleared by input voltage repower on, module re-enabled by remote on/off or module re-enabled by PMBUS 0x01 OPERATION command. The Vo OVP function could be changed via PMBUS. The command related to Vo OVP function are VOUT_OV_WARN_LIMIT, VOUT_OV_FAULT_LIMIT and VOUT_OV_FAULT_RESPONSE.

Over-Temperature Protection

The over-temperature protection consists of circuitry that provides protection from thermal damage. If the temperature exceeds the over-temperature threshold the module will shut down. The module will restart after the temperature is within specification

Remote On/Off

The primary remote on/off feature on the module can be either negative or positive logic. Negative logic turns the module on during a logic low and off during a logic high. Positive logic turns the modules on during a logic high and off during a logic low.

The primary remote on/off can be controlled by an external switch between the on/off terminal and the Vi (-) terminal. The switch can be an open collector or open drain. If the remote on/off feature is not used, for negative logic, please short the on/off pin to Vi (-); For positive logic, please leave the on/off pin floating.

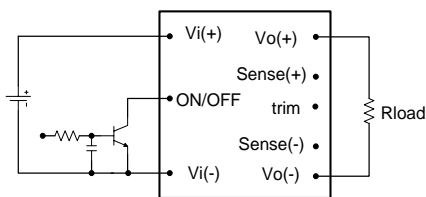

Figure 14: Remote On/Off Implementation

Remote Sense

Remote sense minimizes the effects of distribution losses by regulating the voltage at the remote-sense connections. The SENSE(-) pin should be always connected to VO(-) pin. The voltage between the remote-sense pins and the output terminals must not exceed the output voltage sense range given in the Feature Specifications

$$VO(+)-SENSE(+)\leq 1.2V$$

$$SENSE(-)-VO(-)\leq 0.12V$$

The output voltage can also be increased by the trim, the maximum increase for the output voltage is the sum of both. The amount of power delivered by the module is defined as the voltage at the output terminals multiplied by the output current. When using remote sense and trim, the output voltage of the module can be increased, which at the same output current, would increase the power output of the module. Care should be taken to ensure that the maximum output power of the module remains at or below the maximum rated power (Maximum rated power = Vo,set x Io,max)

Output Voltage Adjustment (Analog TRIM)

To increase or decrease the output voltage set point, connect an external resistor between the TRIM pin and either the Sense(+) or Sense(-). The TRIM pin should be left open if this feature is not used.

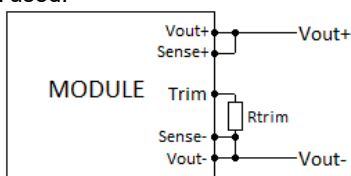

Figure 15: Circuit configuration for trim-down (decrease output voltage)

If the external resistor is connected between the TRIM and Sense (-) pins, the output voltage set point decreases (Fig. 16). The external resistor value required to obtain a percentage of output voltage change $\Delta\%$ is defined as:

$$R_{trim_down} = \left[\frac{511}{\Delta} - 10.2 \right] (K\Omega)$$

Ex. When Trim-down -10% ($12V \times 0.9 = 10.8V$)

$$R_{trim_down} = \left[\frac{511}{10} - 10.2 \right] (K\Omega) = 40.88(K\Omega)$$

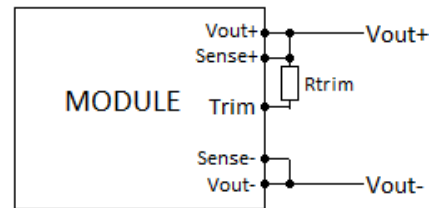

Figure 16: Circuit configuration for trim-up (increase output voltage)

If the external resistor is connected between the TRIM and Sense(+) the output voltage set point increases (Fig.16) The external resistor value required to obtain a percentage output voltage change $\Delta\%$ is defined as:

$$R_{trim_up} = \frac{5.11V_o(100+\Delta)}{1.225\Delta} - \frac{511}{\Delta} - 10.2(K\Omega)$$

Ex. When Trim-up +10% ($12V \times 1.1 = 13.2V$)

$$R_{trim_up} = \frac{5.11 \times 12 \times (100 + 10)}{1.225 \times 10} - \frac{511}{10} - 10.2 = 489.3(K\Omega)$$

Power Good, PG

The module provides a Power Good (PG) signal which need external pull-up to a high level, voltage level is 3.3V, PG pin is open drain, to indicate that the output voltage is within the normal output voltage range of the power module. The PG signal will be de-asserted to a low state if any condition such as over temperature, overcurrent or loss of regulation occurs that would result in the output voltage going below the normal voltage range value. The Vout PG function could be changed via PMBUS. The command related to Vout PG function are POWER_GOOD_ON and POWER_GOOD_OFF.

At the beginning of 20mS after Vin is applied to the module, PG maintain high although the Vout doesn't start up. After this 20mS, module internal MCU finish initialization and the PG indicate output voltage correctly, please refer to below picture.

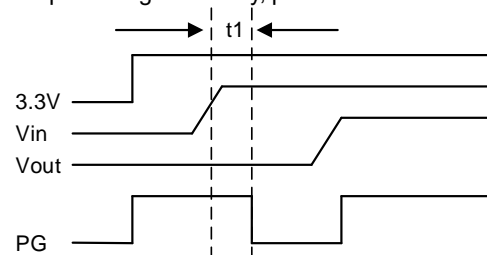

Thermal Testing Setup (Airflow Cooling)

Thermal management is an important part of the system design. To ensure proper, reliable operation, sufficient cooling of the power module is needed over the entire temperature range of the module. Convection cooling is usually the dominant mode of heat transfer.

Hence, the choice of equipment to characterize the thermal performance of the power module is a wind tunnel.

Delta's DC/DC power modules are characterized in heated vertical wind tunnels that simulate the thermal environments encountered in most electronics equipment. This type of equipment commonly uses vertically mounted circuit cards in cabinet racks in which the power modules are mounted.

The following figure shows the wind tunnel characterization setup. The power module is mounted on a 185mmX185mm, 105µm (3Oz), 8 layers' test PWB and is vertically positioned within the wind tunnel. The space between the neighboring PWB and the top of the power module is constantly kept at 6.35mm (0.25").

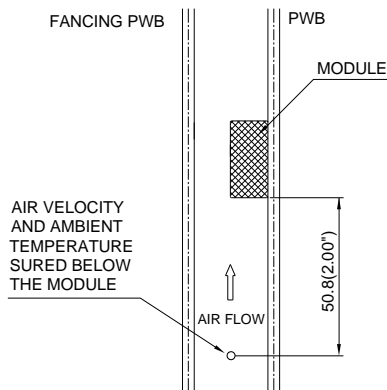

Note: Wind Tunnel Test Setup Figure Dimensions are in millimeters and (Inches)

Figure 17: Wind Tunnel Test Setup

Thermal De-rating

Heat can be removed by increasing airflow over the module. To enhance system reliability, the power module should always be operated below the maximum operating temperature. If the temperature exceeds the maximum module temperature, reliability of the unit may be affected.

Thermal Curves (with heat spreader)

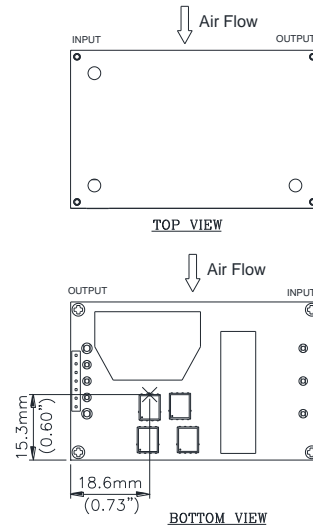

Figure 18: Hot spot 1 temperature measurement location

The allowed maximum hot spot 1 temperature is defined at 123 °C.

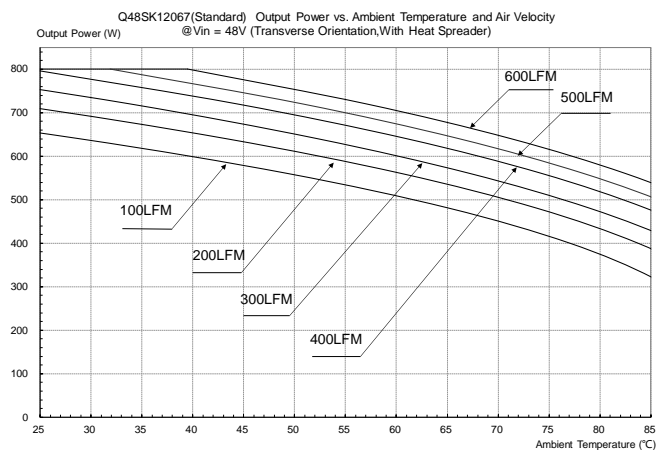

Figure 19: Output Power vs. Ambient Temperature and Air Velocity @Vin = 48V (Transverse Orientation, Airflow from Vin+ to Vin-, With Heat Spreader)

Thermal Curves (with 0.27" height heat sink)

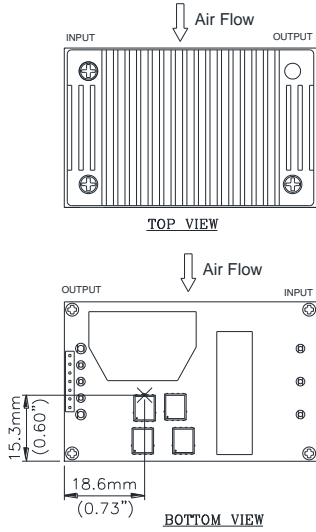

Figure 20: Hot spot 2 temperature measurement location

The allowed maximum hot spot 2 temperature is defined at 123 °C.

Thermal Curves (with 0.5" height heat sink QTL050A)

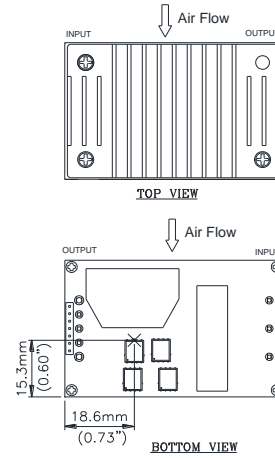

Figure 22: Hot spot 3 temperature measurement location

The allowed maximum hot spot 3 temperature is defined at 123 °C.

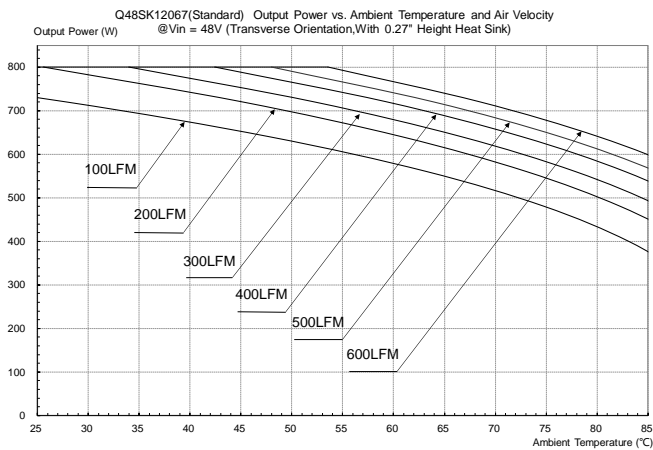

Figure 21: Output Power vs. Ambient Temperature and Air Velocity @ Vin = 48V (Transverse Orientation, Airflow from Vin+ to Vin-, With 0.27" Height Heat Sink)

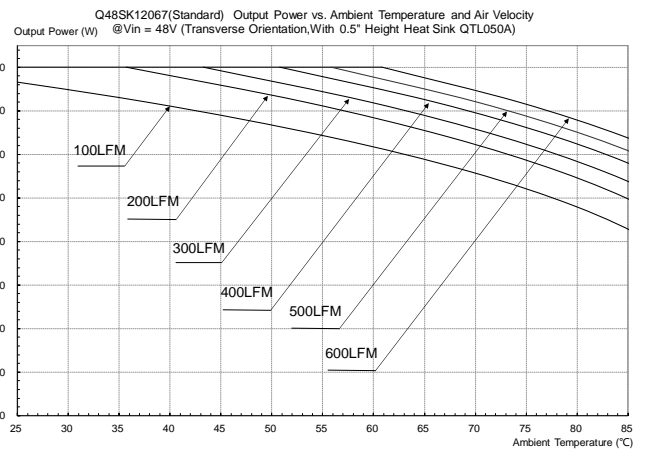

Figure 23: Output Power vs. Ambient Temperature and Air Velocity @ Vin = 48V (Transverse Orientation, Airflow from Vin+ to Vin-, With 0.5" Height Heat Sink QTL050A)

Cold Plate Cooling (Water Cooling)

Thermal management is an important part of the system design. To ensure proper, reliable operation, sufficient cooling of the power module is needed over the entire temperature range of the module.

Thermal Testing Setup

The following figure shows thermal test setup. The power module is mounted on a test PWB and attached to cold plate with thermal interface material (TIM).

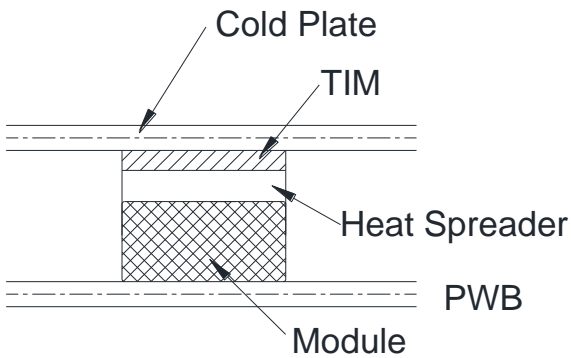

Figure 24: Thermal test setup

Thermal Derating

To enhance system reliability, the power module should always be operated below the maximum heat spreader temperature. If the temperature exceeds the maximum heat spreader temperature, reliability of the unit may be affected.

Thermal Curves (Heat Spreader is attached to Cold Plate)

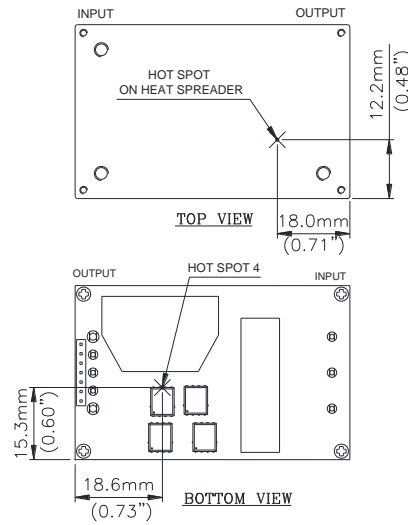

Figure 25: * Hot spot on heat spreader and Hot spot 4 temperature measurement locations. The allowed maximum hot spot 4 temperature is defined at 123 °C.

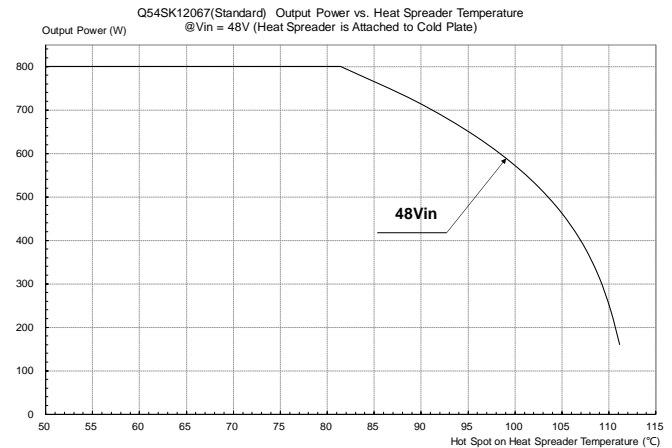

Figure 26: Output Power vs. Hot Spot on Heat Spreader Temperature @Vin=48V(Heat spreader is attached to Cold Plate)

Digital Feature Descriptions

The module has a digital PMBus interface to allow the module to be monitored, controlled and configured by the system. The module supports 4 PMBus signal lines, Data, Clock, SMBALERT (optional), POWER_GOOD (optional), and 2 Address line Addr0 and Addr1. More detail PMBus information can be found in the PMBUS Power Management Protocol Specification, Part I and part II, revision 1.3; which is shown in <http://pmbus.org>. Both 100kHz and 400kHz bus speeds are supported by the module. Connection for the PMBus interface should be following the High Power DC specifications given in section 4.3.4 in the SMBus specification V3.0 or the Low Power DC specifications in section 4.3.3. The complete SMBus specification is shown in <http://smbus.org>.

The module supports the Packet Error Checking (PEC) protocol. It can check the PEC byte provided by the PMBus master, and include a PEC byte in all message responses to the master. And the module also can communicate with the master that does not implement the PEC mechanism.

SMBALERT protocol is also supported by the module. SMBALERT line is also a wired-AND signal; by which the module can alert the PMBUS master via pulling the SMBALERT pin to an active low. There is only one way that the master and the module response to the alert of SMBALERT line.

This way is for the module used in a system that does not support Alert Response Address (ARA). The module is to retain its resistor programmed address, when it is in an ALERT active condition. The master will communicate with the slave module using the programmed address, and using the various READ_STATUS commands to find who cause for the SMBALERT. The CLEAR_FAULTS command will clear the SMBALERT.

The module contains a one-time programmable memory (OTP) used to store configuration settings, which will not be programmed into the device OTP automatically. The STORE_USER_CODE(0x17) command must be used to commit the current settings are transfer from RAM to OTP as device defaults.

Note: The one-time programmable memory (OTP) has limited storing times, frequent use of STORE_USER_CODE commands can lead to memory space exhaustion.

PMBUS Addressing

The Module has flexible PMBUS addressing capability. When connect different resistor from Addr0 and Addr1 pin to GND pin, 64 possible 7bits addresses can be acquired. PMBUS address mentioned below are all 7bits format. The address is in the form of decimal digits; Each pin offers one decimal digit, and then combine together to form the decimal address as shown in below.

$$\text{Address} = 8 * \text{ADDR1} + \text{ADDR0}$$

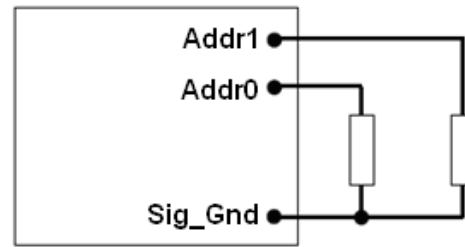

Corresponded to each octal digit, the requested resistor values are shown in below, and +/-1% resistors accuracy can be accepted. If there are any resistances exceeding the requested range, address 97 will be return. 0-12 and 40, 44, 45, 55, and 64-68, 72-75, 120-127 in decimal address can't be used, since they are reserved according to the SMBus specifications, and which will also return address 97.

Address 10 is already used by the IC in this module, so users should not use address 10 to communicate with this module.

Decimal digit	Resistor (Kohm)
0	10
1	15.4
2	23.7
3	36.5
4	54.9
5	84.5
6	130
7	200

PMBus Data Format

The module receives and report data in LINEAR format. The Exponent of the data words is fixed at a reasonable value for the command; altering the exponent is not supported. DIRECT format is not supported by the module.

For commands that set or report any voltage thresholds related to the output voltage, the module supports the linear data format consisting of a two-byte value with a 16-bit, unsigned mantissa, and a fixed exponent of -12. The format of the two data bytes is shown below:

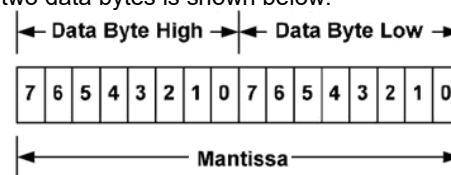

The equation can be written as:

$$V_{out} = \text{Mantissa} \times 2^{-12}$$

For example, considering set V_{out} to 12V by VOUT_COMMAND, the read/write data can be calculated refer to below process:

$$\text{Mantissa} = V_{out} / 2^{-12} = 12 / 2^{-12} = 49152;$$

Converter the calculated Mantissa to hexadecimal 0xC000.

For commands that set or report all other thresholds, including input voltages, output current, temperature, time and frequency, the supported linear data format is a two-byte value with: an 11 bit, two's complement mantissa, and a 5 bit, two's complement exponent (scaling factor). The format of the two data bytes is shown as in below.

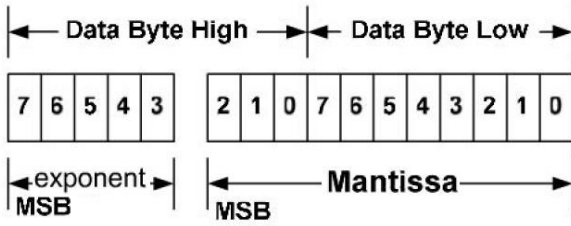

The equation can be written as:

$$\text{Value} = \text{Mantissa} \times 2^{(\text{exponent})}$$

For example, considering set the turn on threshold of input under voltage lockout to 34V by VIN_ON command; the read/write data can be calculated refer to below process:

Get the exponent of Vin, -3; whose binary is 11101

$$\text{Mantissa} = \text{Vin} / 2^{(-3)} = 34 / 2^{(-3)} = 272;$$

Converter the calculated Mantissa to hexadecimal 110, then converter to binary 00100010000;

Combine the exponent and the mantissa, 11101 and 00100010000;

Converter binary 1110100100010000 to hexadecimal E910.

The detail exponent and resolution of main parameter is summarized as below:

	Exponent	Resolution
Vin	-2/-3	0.25V/0.125V
Vo	-12	0.244mV
Io	-3/0	125mA/1A
Temperature	0	1°C
Switching frequency	0	1Khz
Time	-2	0.25ms
Power	0	1W

Supported PMBus Commands

The main PMBus commands described in the PMBus 1.3 specification are supported by the module. Partial PMBus commands are fully supported; Partial PMBus commands have difference with the definition in PMBus 1.3 specification. All the supported PMBus commands are detail summarized in below table.

Command	Command Code	Command description	Transfer type	Compatible with standard PMBUS or not?	Data Format	Default value	Range limit	Data units	Exponent	Note
OPERATION	0x01	Turn on or off	R/W byte	Refer to below description;	Bit field	0x80	/	/	/	/
ON_OFF_CONFIG	0x02	Configures primary on/off & command	R/W byte	Yes	Bit field	0x1D	/	/	/	0x1D (Neg Logic); 0x1F (Pos Logic);
CLEAR_FAULTS	0x03	Clear any fault bits that have been set	Send byte	Yes	/	/	/	/	/	/
WRITE_PROTECT	0x10	Control writing to the PMBUS device.	R/W byte	Yes	/	0x80	0x00, 0x20, 0x40, 0x80	/	/	To protect accidental changes.
STORE_USER_CODE	0x17	Store a command's data from RAM to non-volatile memory OTP.	Write byte	Yes	/	/	/	/	/	The one byte data this command write is the command that user want to store.
CAPABILITY	0x19	Information of a PMBus device	Read byte	Yes	/	0xB0	/			
VOUT_MODE	0x20	Read Vo data format	Read byte	Yes	mode+exp	0x14	/	/	/	/
VOUT_COMMAND	0x21	Read or write the output voltage	R/W word	Yes	Vout Linear	12.0	9.6~13.2	V	-12	/
VOUT_MARGIN_HIGH	0x25	Read or write the output voltage margin high value	R/W word	Yes	Vout Linear	13	10~13.8	V	-12	
VOUT_MARGIN_LOW	0x26	Read or write the output voltage margin low value	R/W word	Yes	Vout Linear	11	9.2~12.6	V	-12	
VIN_ON	0x35	Read or write the turn on voltage threshold of Vin under voltage lockout	R/W word	Yes	Vin Linear	35	34~36	V	-2	VIN_ON should be higher than VIN_OFF.
VIN_OFF	0x36	Read or write the turn off voltage threshold of Vin under voltage lockout	R/W word	Yes	Vin Linear	32	31~34	V	-2	VIN_ON should be higher than VIN_OFF.
VOUT_OV_FAULT_LIMIT	0x40	Read or write the output overvoltage fault threshold.	R/W word	Yes	Vout Linear	15	11~15.99	V	-12	Must be higher than the value of VOUT_COMMAND and VOUT_OV_WARN_LIMIT;
VOUT_OV_FAULT_RESPONSE	0x41	Instructs what action to take in response to an output overvoltage fault.	R/W byte	Refer to below description;	Bit field	0x9E	/	/	/	Default retry 3 times before latch.
VOUT_OV_WARN_LIMIT	0x42	Read or write a threshold causing an output voltage high warning.	R/W word	Yes	Vout Linear	14	10~15.99	V	-12	Must be less than VOUT_OV_FAULT_LIMIT value
IOUT_OC_FAULT_LIMIT	0x46	Read or write the output overcurrent fault threshold.	R/W word	Yes	Iout Linear	100	70~110	A	0	Must be greater than IOUT_OC_WARN_LIMIT value
IOUT_OC_FAULT_RESPONSE	0x47	Instructs what action to take in response to an output overcurrent fault.	R/W byte	Refer to below description;	Bit field	0xDE	/	/	/	Default retry 3 times before latch.

Command	Command Code	Command description	Transfer type	Compatible with standard PMBUS or not?	Data Format	Default value	Range limit	Data units	Exponent	Note
IOUT_OC_WARN_LIMIT	0x4A	Read or write a threshold causing an output current high warning.	R/W word	Yes	Iout Linear	85	69~109	A	0	Must be less than IOUT_OC_FAULT_LIMIT, MFR_SLOW_OCP_FAULT_LIMIT value.
OT_FAULT_LIMIT	0x4F	Read or write the over temperature fault threshold.	R/W word	Yes	TEMP Linear	130	100~140	°C	0	Must be greater than OT_WARN_LIMIT value
OT_WARN_LIMIT	0x51	Read or write a threshold causing a temperature high warning.	R/W word	Yes	TEMP Linear	110	100~140	°C	0	Must be less than OT_FAULT_LIMIT value
VIN_UV_WARN_LIMIT	0x58	Read or write the value of the input voltage that causes an input voltage low warning.	R/W word	Yes	Vin Linear	34	32~35	V	-2	Must be greater than VIN_UV_FAULT_LIMIT value
VIN_UV_FAULT_LIMIT	0x59	Read or write the value of the input voltage that causes an fast Input Under voltage Fault.	R/W word	Yes	Vin Linear	30	28~31	V	-2	Must be less than VIN_UV_WARN_LIMIT value
POWER_GOOD_ON	0x5E	Read or write the output voltage at which the bit 3 of STATUS_WORD high byte should be asserted.	R/W word	Yes	Vout Linear	11.5	8~13	V	-12	Must be greater than POWER_GOOD_OFF value
POWER_GOOD_OFF	0x5F	Read or write the output voltage at which the bit 3 of STATUS_WORD high byte should be negated.	R/W word	Yes	Vout Linear	10.8	6~12	V	-12	Must be less than POWER_GOOD_ON value
TON_DELAY	0x60	Read or write the time from input voltage condition is received until the output voltage starts to rise	R/W word	Yes	Time Linear	18	16~20	ms	-2	/
TON_RISE	0x61	Read or write the time from the output starts to rise until the voltage has entered the regulation band.	R/W word	Yes	Time Linear	20	18~22	ms	-2	/
STATUS_WORD	0x79	Returns the information with a summary of the module's fault/warning	Read word	Refer to below description;	Bit field	/	/	/	/	/
STATUS_VOUT	0x7A	Returns the information of the module's output voltage related fault/warning	R/W byte	Refer to below description;	Bit field	/	/	/	/	ALL of the warning or fault bits set in the status registers remain set, even if the fault or warning condition is removed or corrected, until one of the following occur: 1) The bit is individually cleared; 2) The device receives a CLEAR_FAULTS command; 3) Bias power is removed from the module. 4) Operation command or Enable pin turn on the module.
STATUS_IOUT	0x7B	Returns the information of the module's output current related fault/warning	R/W byte	Refer to below description;	Bit field	/	/	/	/	
STATUS_INPUT	0x7C	Returns the information of the module's input over voltage and under voltage fault	R/W byte	Refer to below description;	Bit field	/	/	/	/	
STATUS_TEMPERATURE	0x7D	Returns the information of the module's temperature related fault/warning	R/W byte	Refer to below description;	Bit field	/	/	/	/	
STATUS_CML	0x7E	Returns the information of the module's communication related faults.	R/W byte	Refer to below description;	Bit field	/	/	/	/	
STATUS_MFR_SPECIFIC	0x80	Returns the information of the module's MFR related faults.	R/W byte	Refer to below description;	Bit field	/	/	/	/	Enable pin turn on the module.
READ_VIN	0x88	Returns the input voltage of the module	Read word	Yes	Vin Linear	/	/	V	-3	/
READ_VOUT	0x8B	Returns the output voltage of the module	Read word	Yes	Vout Linear	/	/	V	-12	/
READ_IOUT	0x8C	Returns the output current of the module	Read word	Yes	Iout Linear	/	/	A	-3	/
READ_TEMPERATURE_1	0x8D	Returns the module's hot spot temperature of the module	Read word	Yes	TEMP Linear	/	/	°C	0	/
READ_PIN	0x97	Returns the input power of the module	Read word	Yes	Power Linear	/	/	W	0	/
PMBUS_REVISION	0x98	Reads the revision of the PMBus	Read byte	Yes	Bit field	0x33	/	/	/	/

Command	Command Code	Command description	Transfer type	Compatible with standard PMBUS or not?	Data Format	Default value	Range limit	Data units	Exponent	Note
MFR_ID	0x99	Read the manufacturer's ID	Read Block	Yes	ASCII	"DELTA"	/	/	/	Data that read should be converted to ASCII code
MFR_MODEL	0x9A	Set or read the manufacturer's model number	Read Block	Yes	ASCII	"Q48SK12067****"	/	/	/	
MFR_REVISION	0x9B	Set or read the module's label version	Read Block	Yes	ASCII	"SX.X"	/	/	/	
MFR_LOCATION	0x9C	Read the manufacturing location of the device	Read Block	Yes	ASCII	"Thailand"	/	/	/	
MFR_SLOW_OC_FAULT_LIMIT	0xB3	Read or write output current slow overcurrent fault threshold.	R/W word	No	Iout Linear	80	56~88	A	0	/
MFR_SLOW_OC_FAULT_RESPONSE	0xB4	Instructs what action to take in response to a slow output overcurrent fault.	R/W byte	Refer to below description;	Bit field	0x9E	/	/	/	continues to operate (Delay with CC retry), and Default retry 3 times before latch.
MFR_SLOW_VIN_UVP_FAULT_LIMIT	0xB5	Read or write output current slow vin under voltage fault threshold.	R/W word	No	Vin Linear	33	31~34	V	-2	/
MFR_SLOW_VIN_UVP_FAULT_RESPONSE	0xB6	Instructs what action to take in response to a slow input under voltage fault.	R/W byte	Refer to below description;	Bit field	0x78	/	/	/	Operate for delay time
MFR_IOUT_OC_FAST_FAULT_RESPONSE	0xCA	Instructs what action to take in response to a fast output overcurrent fault.	R/W byte	Refer to below description;	Bit field	0xDE	/	/	/	Default retry 3 times before latch.
MFR_READ_BLACKBOX_DATA	0xD0	Read history event from black box at an appointed offset set by command 0xD2 MFR_BLACKBOX_OFFSET	Read Block	No	/	/	/	/	/	/
MFR_IOUT_OC_FAST_FAULT_LIMIT	0xD1	Read or write output current fast overcurrent fault threshold.	R/W word	No	Iout Linear	110	86~125	A	0	/
MFR_BLACKBOX_OFFSET	0xD2	Read black-box offset. And set an appointed history-event offset for 0xD0 Reading	R/W word	No	/	/	/	/	/	Read this command, it will return the next event log offset value x. If want to read the last fault data, write x-1, then send 0xD0 read black box data.

OPERATION [0x01]

Bit number	Purpose	Bit Value	Meaning	Default Settings, 0x80
7:	Enable/Disable the module	1	Output is enabled	1
		0	Output is disabled	
6:	Reserved			0
5:4	Margins	00	No margin	00
		01	Margin low(Act on Fault)	
		10	Margin high(Act on Fault)	
3:0	Reserved			0000

ON_OFF_CONFIG [0x02]

Bit number	Purpose	Bit Value	Meaning	Default Settings 0x1D (negative) /0x1F (positive)
7:5	Reserved			000
4	Controls how the unit responds to the primary on/off pin and the OPERATION command;	1	Module does not power up until commanded by the primary ON/OFF pin and the OPERATION	1
		0	Module power up at any time regardless of the state of the primary ON/OFF pin and the OPERATION	
3	Controls how the unit responds to the OPERATION command	1	Module responds to the 7 bit in the OPERATION	1
		0	Module ignores the 7 bit in the OPERATION	
2	Controls how the unit responds to the primary on/off pin	1	Module requires the primary ON/OFF pin to be asserted to start the unit	1
		0	Module ignores the state of the primary ON/OFF pin	
1	Control logic of primary on/off pin	1	Positive Logic	0, negative; 1, positive.
		0	Negative Logic	
0	Unit turn off delay time control	1	Shut down the module with 0 delay cycle	1

VOUT_OV_FAULT_RESPONSE [0x41]

Bit number	Purpose	Bit Value	Meaning	Default Settings, 0x9E
7:6	Response settings	10	Unit shuts down and responds according to the retry settings	10
5:3	Retry settings	111	Unit continuously restarts while fault is present until commanded off	011
		001-110	The PMBus device attempts to restart the number of times set by these bits.	
		000	Unit does not attempt to restart on fault	
2:0	Delay time setting	000-111	Setting over current hiccup delay time. The time unit is 16ms. Total delay time = $2^{(\text{bit}[2:0])} * 16\text{ms}$	110

IOUT_OC_FAULT_RESPONSE [0x47]

Bit number	Purpose	Bit Value	Meaning	Default Settings, 0xDE
7:6	Response settings	11	Unit shuts down and responds according to the retry settings	11
5:3	Retry settings	111	Unit continuously restarts while fault is present until commanded off	011
		001-110	The PMBus device attempts to restart the number of times set by these bits.	
		000	Unit does not attempt to restart on fault	
2:0	Delay time setting	000-111	Setting over current hiccup delay time. The time unit is 16ms. Total delay time = $2^{(\text{bit}[2:0])} * 16\text{ms}$	110

STATUS_WORD [0x79]
High byte

Bit number	Purpose	Bit Value	Meaning
7	An output voltage fault or warning	1	Occurred
		0	No Occurred
6	An output over current fault or warning	1	Occurred
		0	No Occurred
5	An input voltage fault or warning, including over voltage and under voltage	1	Occurred
		0	No Occurred
4	A manufacturer specific fault or warning	1	Occurred
		0	No Occurred
3	Power Good	1	is negated
		0	ok
2:0	Reserved		

Low byte

Bit number	Purpose	Bit Value	Meaning
7	Reserved		
6	OFF (The unit is not providing power to the output, regardless of the reason)	1	Occurred
		0	No Occurred
5	An output over voltage fault	1	Occurred
		0	No Occurred
4	An output over current fault	1	Occurred
		0	No Occurred
3	An input under voltage fault	1	Occurred
		0	No Occurred
2	A temperature fault or warning	1	Occurred
		0	No Occurred
1	CML (A communications, memory or logic fault)	1	Occurred
		0	No Occurred
0	A fault or warning not listed in bits [7:1] of this byte has occurred	1	Occurred
		0	No Occurred

STATUS_VOUT [0x7A]

Bit number	Purpose	Bit Value	Meaning
7	Output over voltage fault	1	Occurred
		0	No Occurred
6	Output over voltage warning	1	Occurred
		0	No Occurred
5	Output under voltage warning	1	Occurred
		0	No Occurred
4	Output under voltage fault	1	Occurred
		0	No Occurred
3:0	Reserved		

STATUS_IOUT [0x7B]

Bit number	Purpose	Bit Value	Meaning
7	Output over current fault	1	Occurred
		0	No Occurred
6	Reserved		
5	Output over current warning	1	Occurred
		0	No Occurred
4:0	Reserved		

STATUS_INPUT [0x7C]

Bit number	Purpose	Bit Value	Meaning
7	Reserved		
6	Reserved		
5	Input under voltage warning	1	Occurred
		0	No Occurred
4	Input under voltage fault	1	Occurred
		0	No Occurred
3	Off due to VIN OFF	1	Occurred
		0	No Occurred
2:0	Reserved		

STATUS_TEMPERATURE [0x7D]

Bit number	Purpose	Bit Value	Meaning
7	Over temperature fault	1	Occurred
		0	No Occurred
6	Over temperature warning	1	Occurred
		0	No Occurred
5:0	Reserved		

STATUS_CML [0x7E]

Bit number	Purpose	Bit Value	Meaning
7	Invalid/Unsupported Command Received	1	Occurred
		0	No Occurred
6	Invalid/Unsupported Data Received	1	Occurred
		0	No Occurred
5	Packet Error Check Failed	1	Occurred
		0	No Occurred
4:0	Reserved		

STATUS_MFR_SPECIFIC [0x80]

Bit number	Purpose	Bit Value	Meaning
7:6	Reserved		
5	Fast Output Over Current Fault	1	Occurred
		0	No Occurred
4:2	Reserved		
1	Slow Vin Under Voltage Fault	1	Occurred
		0	No Occurred
0	Slow Output Over Current Fault	1	Occurred
		0	No Occurred

MFR_SLOW_OCP_FAULT_RESPONSE [0xB4]

Bit number	Purpose	Bit Value	Meaning	Default Settings, 0x9E
7:6	Response settings	10	If the fault happens continuously for a delay time, the unit will shut down and respond according to the retry settings	10
5:3	Retry settings	111	Unit continuously restarts while fault is present until commanded off	011
		001-110	The PMBus device attempts to restart the number of times set by these bits.	
		000	Unit does not attempt to restart on fault	
2:0	Delay time setting	000-111	Setting over current hiccup delay time. The time unit is 16ms. Total delay time = $2^{(\text{bit}[2:0])} * 16\text{ms}$	110

MFR_SLOW_VIN_UVP_FAULT_RESPONSE [0xB6]

Bit number	Purpose	Bit Value	Meaning	Default Settings, 0x78
7:6	Response settings	01	If the fault happens continuously for a delay time, the unit will shut down and respond according to the retry settings.	01
5:3	Retry settings	111	Unit continuously restarts while fault is present until commanded off	111
		001-110	The PMBus device attempts to restart the number of times set by these bits.	
		000	Unit does not attempt to restart on fault	
2:0	Delay time setting	000-111	Setting over current hiccup delay time. The time unit is 16ms. Total delay time = $2^{(\text{bit}[2:0])} * 16\text{ms}$	000

MFR_IOUT_OC_FAST_FAULT_RESPONSE [0xCA]

Bit number	Purpose	Bit Value	Meaning	Default Settings, 0xDE
7:6	Response settings	11	Unit shuts down and responds according to the retry settings	11
5:3	Retry settings	111	Unit continuously restarts while fault is present until commanded off	011
		001-110	The PMBus device attempts to restart the number of times set by these bits.	
		000	Unit does not attempt to restart on fault	
2:0	Delay time setting	000-111	Setting over current hiccup delay time. The time unit is 16ms. Total delay time = $2^{(\text{bit}[2:0])} * 16\text{ms}$	110

Black Box

HISTORY EVENT READ SECTION:

- **0xD2 command: Write the Offset Value to Slave to decide which history data for read.**
- **0xD0 command: read the history data after 0xD2 command**

When the power module fault happens (OVP, OCP, OTP), the MCU inside power module write information in below table into black box. The PMBUS command code MFR_READ_BLACKBOX_DATA command (Register 0xD0) is a block read command that returns the appointed black box index with all related data in below table.

Byte	Register Name
0	Byte Count = 31
1 to 8	Reserved
9:11	Run time from turn on to off
12	The last PMbus command
13:14	PMBus temperature when off
15:16	STATUS_WORD
17:18	PMBUS-Vin, when off
19:20	PMBus-Vin,1ms before off
21:22	PMBus-Iout, when off
23:24	PMBus-Io,1ms before off
25:26	Duty, when off
27:28	PMBus-Vo, when off
29 to 31	Reserved

Because these commands are block read commands, the first byte returned by slave is called the BYTE_COUNT and indicates the PMBus master how many bytes needs to read. In this module, the BYTE_COUNT = 31. The module will return 31 bytes black box data from Byte 1 to byte 31.

In Byte 15 and 16, Returns the information with a summary of the module's fault/warning when fault happens. It includes the OCP, OVP, OTP and so on. More information please refer to STATUS_WORD [0x79] command.

In Byte 17 to 28, record input voltage, output voltage, output current, duty when power module fault happens.

The available storage size to record black box is 8KB (0x1002E000 – 0x10030000). The maximum records quantity is 170 times.

The following is the Black-Box data read steps.

READ MFR_BLACKBOX_OFFSET [0xD2]

Send command 0xD2 and read one byte, it will return the next event log offset value x.

Start	Device Address & R/W	Command byte(0xD2)	Repeated Start	Device Address & R/W
Event log offset value		PEC	Stop	

SET MFR_BLACKBOX_OFFSET [0xD2]

Then send command 0xD2 and write the offset value x-1. if send command 0xD0 to read data after this write command 0xD2, the last event data will be read back.

Start	Device Address & R/W	Command byte(0xD2)	Offset value	PEC	Stop
-------	----------------------	--------------------	--------------	-----	------

READ MFR_READ_BLACKBOX_DATA [0xD0]

Send Read-Block command 0xD0, the appointed index black box data will be read back.

Start	Device Address & R/W	Command byte(0xD0)	Repeated Start
Device Address & R/W	Block size (0x1F)	Byte1 to Byte31 in above table	PEC Stop

Soldering Method

Generally, as the most common mass soldering method for the solder attachment, wave soldering is used for through-hole power modules and reflow soldering is used for surface-mount ones. Delta recommended soldering methods and process parameters are provided in this document for solder attachment of power modules onto system board. SAC305 is the suggested lead-free solder alloy for all soldering methods. The soldering temperature profile presented in this document is based on SAC305 solder alloy.

Reflow soldering is not a suggested method for through-hole power modules due to many process and reliability concerns. If you have this kind of application requirement, please contact Delta sales or FAE for further confirmation.

Wave Soldering (Lead-free)

Delta's power modules are designed to be compatible with single-wave or dual wave soldering. The suggested soldering process must keep the power module's internal temperature below the critical temperature of 217°C continuously. The recommended wave-soldering profile is shown below:

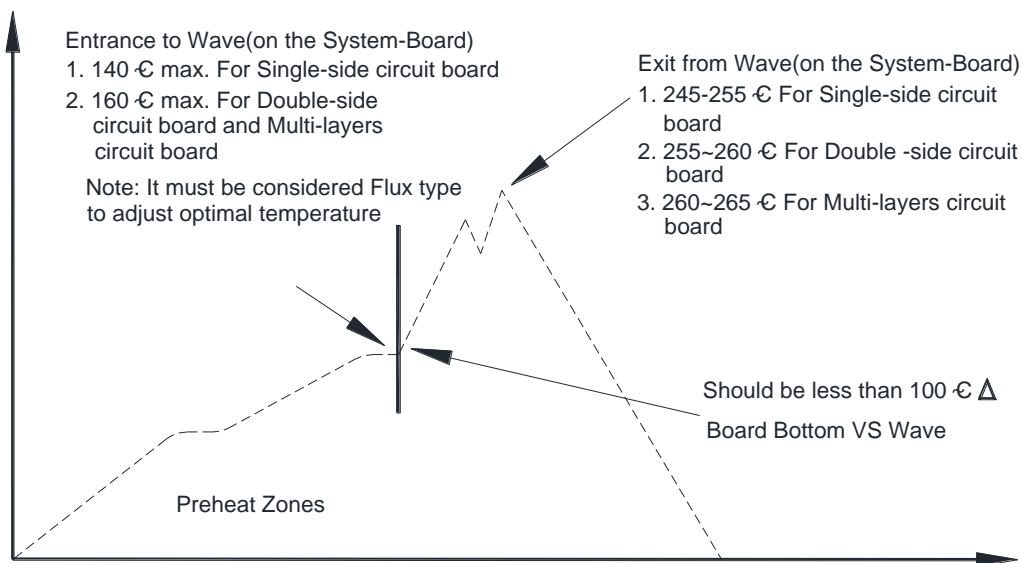

Recommended Temperature Profile for Lead-free Wave Soldering
Note: The temperature is measured on solder joint of pins of power module.

The typical recommended (for double-side circuit board) preheat temperature is 115 \pm 10°C on the top side (component side) of the circuit board. The circuit-board bottom-side preheat temperature is typically recommended to be greater than 135°C and preferably within 100°C of the solder-wave temperature. A maximum recommended preheat up rate is 3°C /s. A maximum recommended solder pot temperature is 255 \pm 5°C with solder-wave dwell time of 3~6 seconds. The cooling down rate is typically recommended to be 6°C/s maximum.

Hand Soldering (Lead Free)

Hand soldering is the least preferred method because the amount of solder applied, the time the soldering iron is held on the joint, the temperature of the iron, and the temperature of the solder joint are variable. The recommended hand soldering guideline is listed in Table below. The suggested soldering process must keep the power module's internal temperature below the critical temperature of 217°C continuously.

Parameter	Single-side Circuit Board	Double-side Circuit Board	Multi-layers Circuit Board
Soldering Iron Wattage	90	90	90
Tip Temperature	385 \pm 10°C	420 \pm 10°C	420 \pm 10°C
Soldering Time	2 ~ 6 seconds	4 ~ 10 seconds	4 ~ 10 seconds



CONTACT US:

Website: www.deltaww.com/dcdc

Email: dcdc@deltaww.com

USA:

Telephone:

East Coast: 978-656-3993

West Coast: 510-668-5100

Fax: 510-668-0680

Europe:

Telephone: +31-20-800-3900

Fax: +31-20-800-3999

Asia & the rest of world:

Telephone: +886-3-452-6107

Ext. 6221~6226

Fax: +886-3-433-1810

WARRANTY

Delta offers a two (2) year limited warranty. Complete warranty information is listed on our web site or is available upon request from Delta.

Information furnished by Delta is believed to be accurate and reliable. However, no responsibility is assumed by Delta for its use, nor for any infringements of patents or other rights of third parties, which may result from its use. No license is granted by implication or otherwise under any patent or patent rights of Delta. Delta reserves the right to revise these specifications