

## Wall mount

## HEF160VAA series



### Dimension drawing

Filter Fan Unit (HEF160VAA)

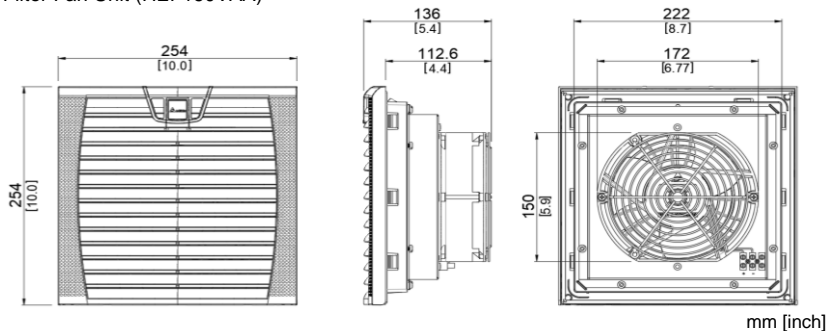

Exhaust Grille package (HEF1600ACA)

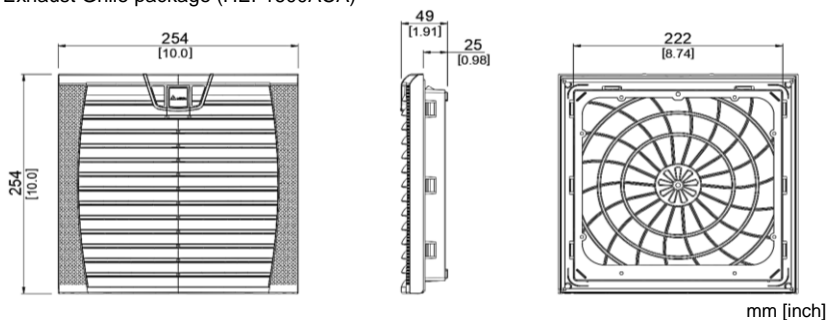

### Features

- ◆ Reliable and energy efficient thermal solutions
- ◆ Energy efficient fans
- ◆ IP54 waterproof at external side
- ◆ High efficiency filter(G3/G4)
- ◆ UL 508 / TYPE12 Certification

### Design

- ◆ Quick installation
- ◆ Easy filter replacement
- ◆ Standard rope gasket
- ◆ Pin to pin cut-out sizes on the market
- ◆ Terminal block connections

MAIN FEATURE	UNIT	Model Name
		HEF160VAA
Input Voltage	VDC	24
Rated Current	A	0.57
Power Consumption	W	13.7
Free Airflow	CMH (CFM)	272 (160)
Airflow rate in filter with Exhaust Grille	CMH (CFM)	229 (135)
Power Connection	Terminal Block	
Unit Dimension (H x W x D)	mm (inch)	254 x 254 x 136 (10.0 x 10.0 x 5.35)
Cutout Dimension (H x W)	mm (inch)	224 x 224 (8.82 x 8.82)
Weight	Kg (lbs)	1.60 (3.53)
Color	RAL 7035 (light-gray)	
Noise (Sound pressure)	dB-A	55
Operating Temperature Range	°C (°F)	-10 ~ +55 (+14 ~ +131)
Service Life (L <sub>10</sub> )	hours	70,000 at 40°C
Protection Category	EN60529	IP54
Protection Category	UL508	NEMA Type 12

\* Specifications are subject to change without notice.