

The power behind competitiveness

Delta UPS - Ultron Family

DPS Series, Three Phase
300-600 kVA

User Manual

www.deltapowersolutions.com



SAVE THIS MANUAL

This manual contains important instructions and warnings that you should follow during the installation, operation, storage and maintenance of this product. Failure to heed these instructions and warnings will void the warranty.

Copyright © 2020 by Delta Electronics Inc. All Rights Reserved. All rights of this User Manual (“Manual”), including but not limited to the contents, information, and figures are solely owned and reserved by Delta Electronics Inc. (“Delta”). The Manual can only be applied to the operation or the use of this product. Any disposition, duplication, dissemination, reproduction, modification, translation, extraction, or usage of this Manual in whole or in part is prohibited without the prior written permission of Delta. Given that Delta will continuously improve and develop the product, changes may be made to the information in this Manual at any time without obligation to notify any person of such revision or changes. Delta will make all possible efforts to secure the accuracy and the integrity of this Manual. Delta disclaims any kinds or forms of warranty, guarantee, or undertaking, either expressly or implicitly, including but not limited to the completeness, faultlessness, accuracy, non-infringement, merchantability or fitness for a particular purpose of the Manual.

Table of Content

Chapter 1 : Important Safety Instructions	7
1.1 Installation Warnings.....	7
1.2 Connection Warnings.....	7
1.3 Usage Warnings.....	9
1.4 Storage Warnings	10
1.5 Standard Compliance	10
Chapter 2 : Introduction	11
2.1 General Overview	11
2.2 Inspection.....	11
2.3 Functions & Features.....	14
2.4 Exterior & Dimensions	16
2.5 Front View	17
2.6 Internal View	19
2.7 Tri-color LED Indicator & Buzzer	25
Chapter 3 : Operation Modes	28
3.1 On-Line Mode	28
3.2 Battery Mode.....	29
3.3 Bypass Mode	29
3.4 Manual Bypass Mode	30
3.5 ECO Mode	30
3.6 Frequency Conversion Mode.....	31
Chapter 4 : Communication Interfaces	32
4.1 Communication Interfaces I: on the Front of the UPS with the Front Door Open.....	32
4.1.1 Display Port.....	33
4.1.2 REPO Dry Contacts	33
4.1.3 External Battery Temperature Dry Contacts	39
4.1.4 External Switch/ Breaker Status Dry Contacts	39
4.1.5 Output Dry Contacts	40
4.1.6 Input Dry Contacts	42
4.1.7 Parallel Communication Cards	44

4.1.8	Parallel Ports.....	45
4.1.9	SMART Slot	45
4.1.10	USB Port & RS-232 Port.....	46
4.1.11	Auxiliary Power Cards.....	46
4.1.12	Battery Start Buttons.....	47
4.2	Communication Interfaces II: at the Rear of the Touch Panel	48
Chapter 5 : Installation and Wiring		53
5.1	Before Installation and Wiring	53
5.2	Installation Environment.....	53
5.3	Fixing the UPS	56
5.4	Wiring	59
5.4.1	Pre-wiring Warnings.....	59
5.4.2	Single Input to Dual Input Modification	62
5.4.3	Installation of Insulating Plates for Top & Bottom Wiring	65
5.4.4	Single Unit Wiring	67
5.4.5	Parallel Units Wiring.....	82
5.5	External Battery Cabinet Connection Warnings	89
5.6	Installation of Rodent Shields	97
5.6.1	Installation of 300kVA UPS's Rodent Shields	97
5.6.2	Installation of 400/ 500/ 600kVA UPS's Rodent Shields.....	99
Chapter 6 : UPS Operation.....		101
6.1	Pre Start-up & Pre Turn-off Warnings	101
6.2	Start-up Procedures.....	102
6.2.1	On-Line Mode Start-up Procedures.....	102
6.2.2	Battery Mode Start-up Procedures	103
6.2.3	Bypass Mode Start-up Procedures.....	104
6.2.4	Manual Bypass Mode Start-up Procedures.....	105
6.2.5	ECO Mode Start-up Procedures.....	107
6.2.6	Frequency Conversion Mode Start-up Procedures	109
6.3	Turn-off Procedures	111
6.3.1	On-Line Mode Turn-off Procedures	111
6.3.2	Battery Mode Turn-off Procedures.....	111

6.3.3	Bypass Mode Turn-off Procedures	112
6.3.4	Manual Bypass Mode Turn-off Procedures	112
6.3.5	ECO Mode Turn-off Procedures	112
6.3.6	Frequency Conversion Mode Turn-off Procedures.....	113
6.4	Start-up & Turn off Procedures for Parallel Units.....	113
Chapter 7 : LCD Display & Settings		115
7.1	LCD Display Hierarchy.....	115
7.2	How to Turn on the LCD	118
7.3	Introduction of Touch Panel and Function Keys	119
7.4	Password Entry.....	125
7.5	Check Kilowatt-Hour	125
7.6	UPS Settings.....	127
7.6.1	Bypass Setting	127
7.6.2	Mode Setting	127
7.6.3	Output Setting	128
7.6.4	Battery & Charging Setting	129
7.6.5	Parallel Setting.....	131
7.6.6	Dry Contact Setting.....	131
7.6.7	General Setting	133
7.6.8	IP Setting.....	134
7.6.9	Control.....	134
7.7	System Maintenance	135
7.7.1	Warning.....	135
7.7.2	Historical Event	135
7.7.3	Statistics.....	136
7.7.4	Test.....	136
7.7.5	Clear.....	136
7.7.6	Advanced Diagnosis	137
7.7.7	Version & S/N.....	137
Chapter 8 : Optional Accessories		138
8.1	EMS Function on the LCD Screen.....	140
8.2	BMS Function on the LCD Screen.....	144
8.3	MFC Function on the LCD Screen.....	146

Chapter 9 : Maintenance 148
Appendix 1 : Technical Specifications 149
Appendix 2 : Warranty 152

Chapter 1 : Important Safety Instructions

1.1 Installation Warnings

- This is a three-phase four-wire on-line uninterruptible power supply (hereafter referred to as 'UPS'). It can be used for commercial and industrial applications.
- Install the UPS in a well-ventilated indoor area, away from excess moisture, heat, dust, flammable gas or explosives.
- Leave adequate space around all sides of the UPS for proper ventilation and maintenance. Please refer to **5.2 Installation Environment**.
- Only authorized Delta engineers or service personnel can perform installation and maintenance. If you want to install the UPS by yourself, please install it under the supervision of authorized Delta engineers or service personnel.
- Follow the IEC 60364-4-42 standard to install the UPS.

1.2 Connection Warnings

- Before applying electrical power to the UPS, make sure the UPS is grounded to avoid a possible risk of current leakage.
- You can parallel up to eight UPS units.
- The UPS must be connected with an external battery cabinet (user-supplied, handled and configured by Delta service personnel). Please refer to **5.5 External Battery Cabinet Connection Warnings** for relevant information.
- It is necessary to connect the protective devices with the UPS when the UPS is connected to power sources and critical loads.
- The protective devices connected to the UPS must be installed near the UPS and easily accessible for operation.
- Protective Devices:
 1. For single input, please install (1) a protective device between the main AC source and the UPS and (2) a protective device between the connected critical loads and the UPS.
 2. For dual input, please install (1) a protective device between the main AC source and the UPS, (2) a protective device between the bypass source and the UPS and (3) a protective device between the connected critical loads and the UPS.
 3. Each protective device could be (1) a breaker, (2) a switch connected in series with fuses, or (3) a switch*¹. For the protective device's rated current, please refer to the table below.

**NOTE:**

*1 Only applicable when the UPS has the corresponding built-in fuses, and the configurations of the UPS's built-in fuses must meet the protective device's requirement **No.7** below.

300kVA	400kVA	500kVA	600kVA
800A	1000A	1250A	1500A

4. Each protective device should have the functions of overcurrent protection, short circuit protection, insulating protection and shunt trip feature. Please refer to the table below for the UPS cut-off current (I_{cc}).

300kVA	400kVA	500kVA	600kVA
10kA	12.12kA	15.16kA	18.18kA

5. When selecting the protective devices, please take each power cable's current capacity and the system's overload capacity (please refer to **Appendix 1: Technical Specifications**) into consideration. Besides, the short-circuit capacity of the upstream protective devices must be equal to or larger than the capacity of the UPS's input protective devices.
6. When the UPS has abnormalities and the input short-circuit current reaches 20kA, the UPS's internal semi-conductor fast-acting fuses need 8 ~ 10ms to be blown. Thus, the upstream protective devices' reaction time should be more than 10ms so that the UPS's semi-conductor fast-acting fuses would have sufficient time to block the system breakdown and let the UPS transfer to Bypass mode.
7. If the UPS is supplied by a power source whose neutral is grounded, each protective device must be a 3-pole type. If the UPS is supplied by a power source whose neutral is not grounded, each protective device must be a 4-pole type.
8. The recommended electrical rating of the backfeed protective device is as follows.

300kVA	400kVA	500kVA	600kVA
690V/ 630A	690V/ 800A	690V/ 1000A	690V/ 1250A

1.3 Usage Warnings

- Before installation, wiring and working on the UPS's internal circuits, please completely cut off all power supplying to the UPS, including the input power and battery power.
- The UPS is specifically designed for information technology equipment and used to power computers, servers, and associated peripheral devices. If you want to connect any capacitive loads or non-linear loads (that have serious surge current) to the UPS, it needs to be de-rated according to on-site applications. For such special applications, please contact Delta service personnel for the accurate UPS sizing. The UPS is not suitable for connecting with any asymmetrical loads (e.g. half-bridge motor drivers).
- The external slits and openings in the UPS are provided for ventilation. To ensure reliable operation of the UPS and to protect the UPS from overheating, these slits and openings must not be blocked or covered. Do not insert any object into the slits and openings that may hinder ventilation.
- Before applying electrical power to the UPS, you must allow the UPS to adjust to room temperature (20°C ~ 25°C (68°F ~ 77°F)) for at least one hour to avoid moisture condensing inside the UPS.
- Do not put beverages on the UPS, external battery cabinet(s) or any other accessory associated with the UPS.
- Do not open or remove the covers or panels of the UPS to avoid high-voltage electric shock. Only authorized Delta engineers or service personnel can do so for installation or maintenance. If you want to open or remove the covers or panels, do it only under the supervision of authorized Delta engineers or service personnel.
- It is strictly forbidden to connect the UPS to any regenerative loads (e.g. CNC machines and lifts).
- The risk of dangerous high voltage is possible when batteries are still connected to the UPS even if the UPS is disconnected from the power sources. Before maintenance of the UPS, turn off each external battery cabinet's circuit breaker to completely cut off the battery power from the UPS.
- Do not dispose of the battery or batteries in a fire. The batteries may explode.
- Do not open or damage the battery or batteries. The released electrolyte is harmful to the skin and eyes and may be toxic.
- The UPS is electronic equipment that runs 24 hours continuously. To ensure its normal lifetime, regular maintenance of the UPS and batteries is of vital importance and necessary.
- Some components like batteries, power capacitors, and fans will become worn-out due to long-term usage, and this will increase the risk of UPS failure. To replace and maintain the components, please contact Delta service personnel.

- A battery can present a risk of electric shock and high short-circuit current. The following precautions should be observed before replacement of batteries:
 1. Remove watches, rings, or other metal objects.
 2. Use tools with insulating handles.
 3. Wear insulating gloves and boots.
 4. Do not lay tools or metal parts on the top of batteries.
 5. Disconnect the charging source prior to connecting or disconnecting the battery terminals.
- You must contact Delta customer service if any of the following events occurs:
 1. Any liquid is poured or splashed on the UPS.
 2. The UPS is deformed.
 3. Any conductive powders or metals enter into the UPS.
 4. The UPS does not run normally after you carefully followed the instructions in this ***User Manual***.

1.4 Storage Warnings

- Use the original packing materials to pack the UPS to prevent any possible damage from rodents.
- If the UPS needs to be stored prior to installation, it should be placed in a dry indoor area. The allowable storage temperature is below 70°C (158°F) and relative humidity is below 95%.

1.5 Standard Compliance

- EN 62040-1
- EN 62040-2 Category C3
- EN 61000-4-2 Level 4
- EN 61000-4-3 Level 3
- EN 61000-4-6
- EN 61000-4-4 Level 4
- EN 61000-4-5 Level 4
- YD 5083-2005
- YD/ T 5096-2016
- NEBS GR-63-CORE Zone 4 Earthquake Level Qualification

Chapter 2 : Introduction

2.1 General Overview

The DPS series UPS, a three-phase four-wire online uninterruptible power supply (hereafter referred to as 'UPS'), is a dedicated design for data centers, factory facilities and large scale power systems. The unit not only adopts advanced IGBT technology to provide high quality, low noise, pure and uninterruptible output power to the connected loads but also applies the latest design of DSP digital control technology and highest quality components.

2.2 Inspection

During UPS transportation, some unpredictable situations might occur. It is recommended that you inspect the UPS exterior packaging. If you notice any damage, please immediately contact the dealer from whom you purchased the unit.

Please check if any items are missing according to the following package lists. If the UPS needs to be returned, carefully repack the UPS and all of the accessories using the original packing materials that came with the unit.

300kVA UPS

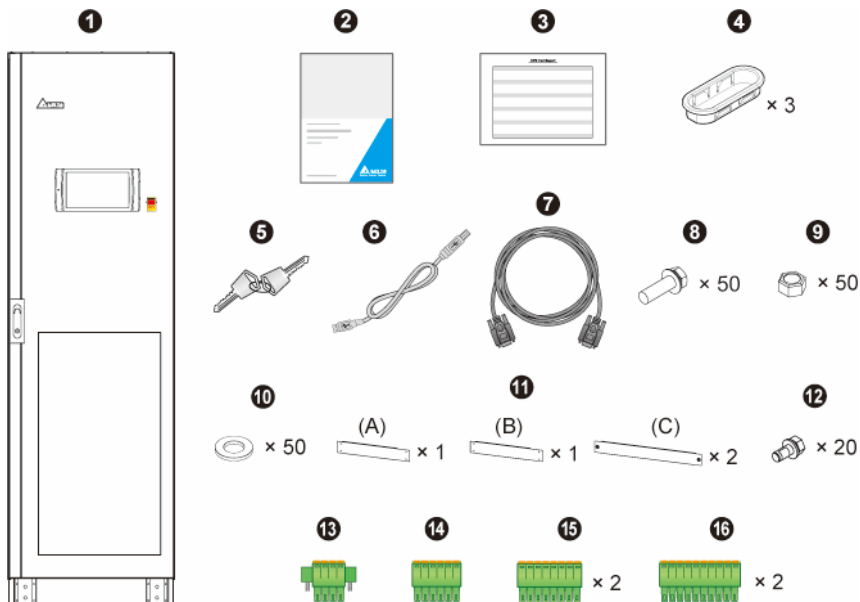

No.	Item	Q'ty
1	UPS	1 PC
2	User Manual	1 PC
3	Test Report	1 PC
4	Snap Bushing	3 PCS
5	Key (placed inside the UPS cabinet)	2 Copies
6	USB Cable	1 PC
7	Parallel Cable	1 PC
8	M12 Screw (used for input/ output/ battery wiring, the screws used for grounding have been fixed on the unit before shipment)	50 PCS
9	M12 Nut (used for input/ output/ battery wiring)	50 PCS
10	Flat Washer (used for input/ output/ battery wiring)	50 PCS
11	Rodent Shield (three types A, B, and C)	4 PCS
12	M5 Screw (used when fixing the rodent shields)	20 PCS
13	4-Pin Dry Contact Terminal Block (used for REPO dry contacts)	1 PC
14	6-Pin Dry Contact Terminal Block (used for MODBUS and BMS ports)	1 PC
15	8-Pin Dry Contact Terminal Block (used for (1) external battery temperature dry contacts and (2) external switch/ breaker status dry contacts)	2 PCS
16	10-Pin Dry Contact Terminal Block (used for input/ output dry contacts)	2 PCS

400/ 500/ 600kVA UPS

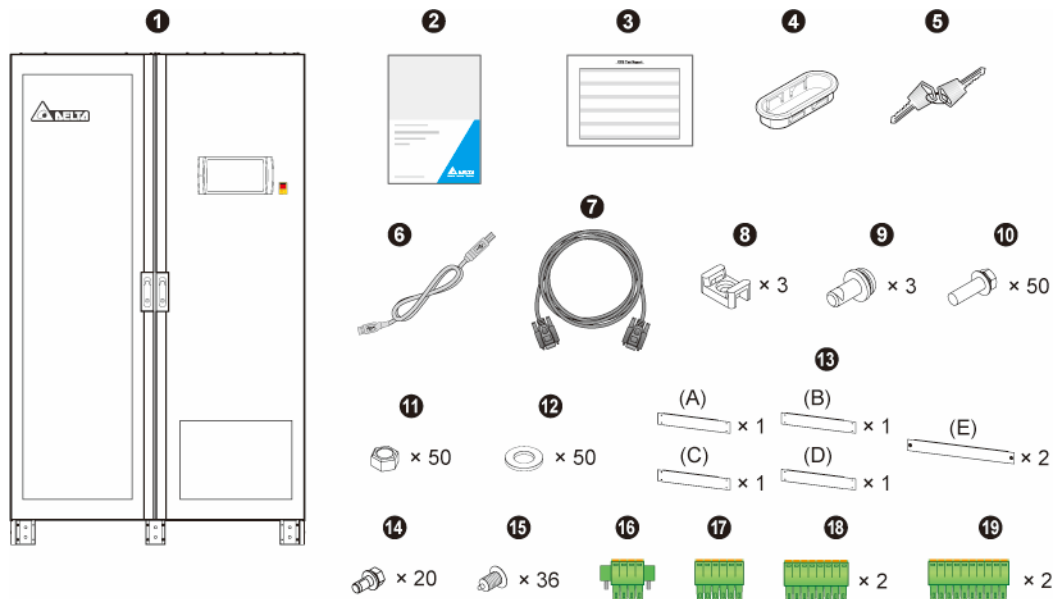

No.	Item	Q'ty
1	UPS	1 PC
2	User Manual	1 PC
3	Test Report	1 PC
4	Snap Bushing	1 PC
5	Key (placed inside the UPS cabinet)	2 Copies
6	USB Cable	1 PC
7	Parallel Cable	1 PC
8	Wire Mount (used for bundling and fixing the signal cables and parallel cables)	3 PCS
9	M4 Screw (used for fixing the wire mounts)	3 PCS
10	M12 Screw (used for input/ output/ battery wiring, the screws used for grounding have been fixed on the unit before shipment)	50 PCS
11	M12 Nut (used for input/ output/ battery wiring)	50 PCS
12	Flat Washer (used for input/ output/ battery wiring)	50 PCS
13	Rodent Shield (five types A, B, C, D, and E)	6 PCS

No.	Item	Q'ty
14	M5 Screw (used when fixing the rodent shields)	20 PCS
15	Plastic Rivet (spare accessories)	36 PCS
16	4-Pin Dry Contact Terminal Block (used for REPO dry contacts)	1 PC
17	6-Pin Dry Contact Terminal Block (used for MODBUS and BMS ports)	1 PC
18	8-Pin Dry Contact Terminal Block (used for (1) external battery temperature dry contacts and (2) external switch/ breaker status dry contacts)	2 PCS
19	10-Pin Dry Contact Terminal Block (used for input/ output dry contacts)	2 PCS

2.3 Functions & Features

- Hot-swappable communication interfaces realize on-line maintenance and reduce the MTTR (Mean Time to Repair).
- Automatic input frequency detection enables operation at 50Hz or 60Hz.
- Automatic restart:
 1. After a low battery shutdown, the UPS inverter will restart in normal mode automatically right after the AC input resumes.
 2. The UPS returns automatically to normal mode from Bypass mode after an overload condition is cleared.
- Automatically detects whether bypass voltage is out of the rated voltage. If yes, the UPS will stop supplying power to the critical loads to protect your electronic equipment.
- Supports ECO mode.
- Both auxiliary power and control circuit adopt redundancy design, which doubly enhances UPS reliability.
- Allows maintenance for the power modules and system components from the top and front of the unit.
- Generator compatible.
- Surge protection and EMI filter functions.
- Remote emergency power off.
- Single input and dual input functions.
- Supports external switch/ breaker status detection.

- Wide AC input voltage range (176/ 304Vac ~ 276/ 478Vac (full load); 132/ 228Vac ~ 276/ 478Vac (70% load)) reduces frequent transfer from normal mode to Battery mode to save battery consumption and prolong battery life.
- Battery start-up function even when there is no AC input.
- AC start-up function even when the UPS is not connected to the batteries.



WARNING:

Please note that when the UPS is not connected to the batteries, it will not protect your equipment if the utility power is lost.

- Connects at maximum four external battery cabinets (optional) to extend the backup time.
- Setting options of battery test (schedulable) and battery replacement alarm.
- Battery temperature monitoring and compensation.
- Optional battery management system (BMS) allows measurement of every battery's voltage.
- Smart battery charger design allows auto-charging or manual charging to shorten the charging time.
- Provides diversified communication interfaces and a SMART slot. Please refer to **4. Communication Interfaces**.
- Built-in memories record at maximum 10,000 event logs.
- Fan speed auto adjustment prolongs fan life and reduces noise when the critical loads decrease. Moreover, fan failure detection circuit is established.
- State-of-the-art microprocessor technology performs self-detection and monitors fan speed in real time, which provides complete and detailed operating status of the UPS.

2.4 Exterior & Dimensions

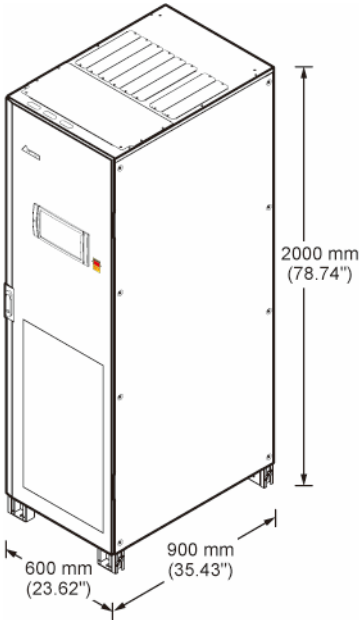

(Figure 2-1: 300kVA UPS_ Exterior & Dimensions)

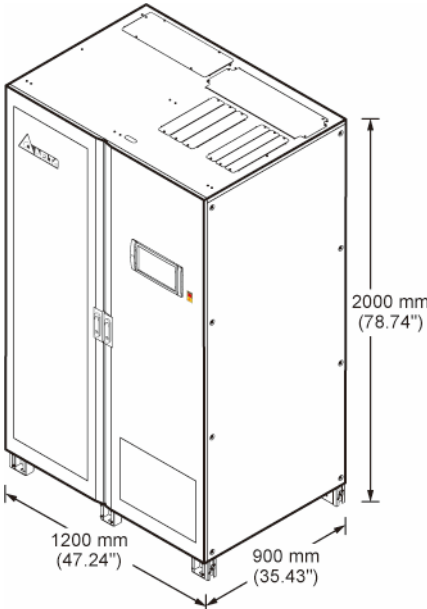

(Figure 2-2: 400/ 500/ 600kVA UPS_ Exterior & Dimensions)

2.5 Front View

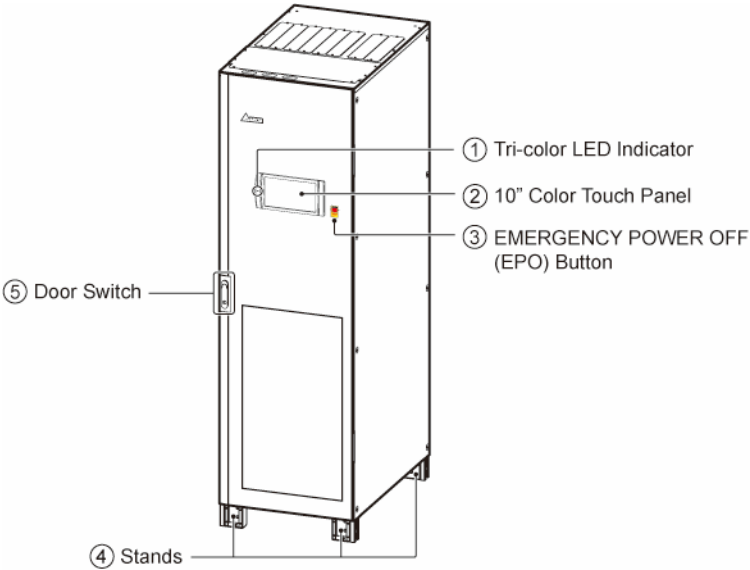

(Figure 2-3: Front View of 300kVA UPS)

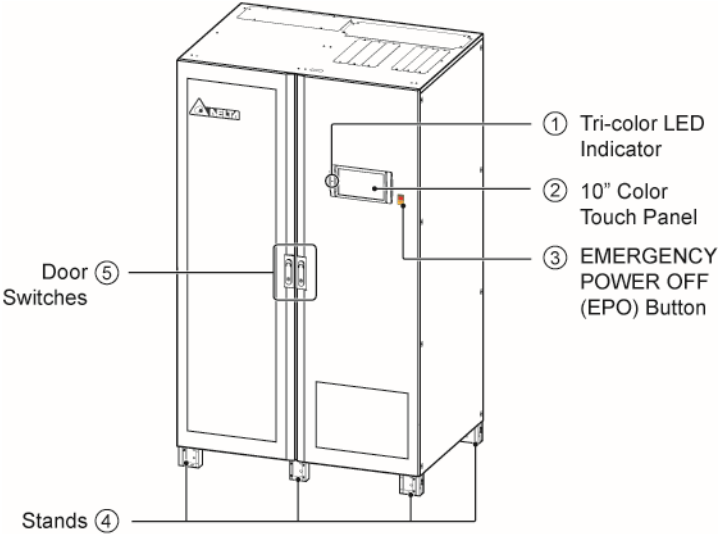

(Figure 2-4: Front View of 400/ 500/ 600kVA UPS)

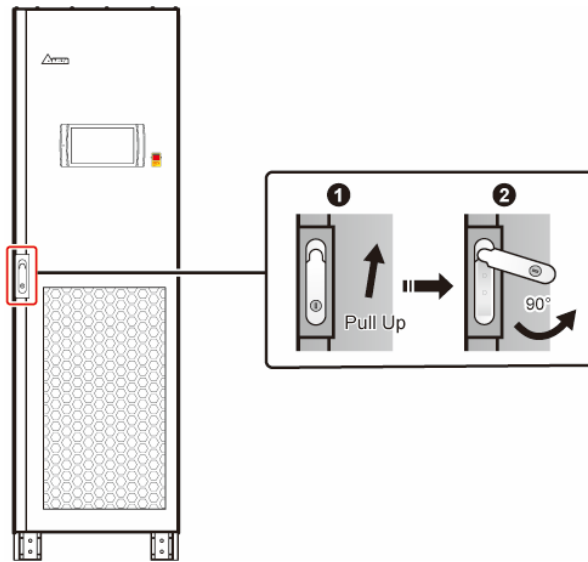

(Figure 2-5: How to Open the Front Door of 300kVA UPS)

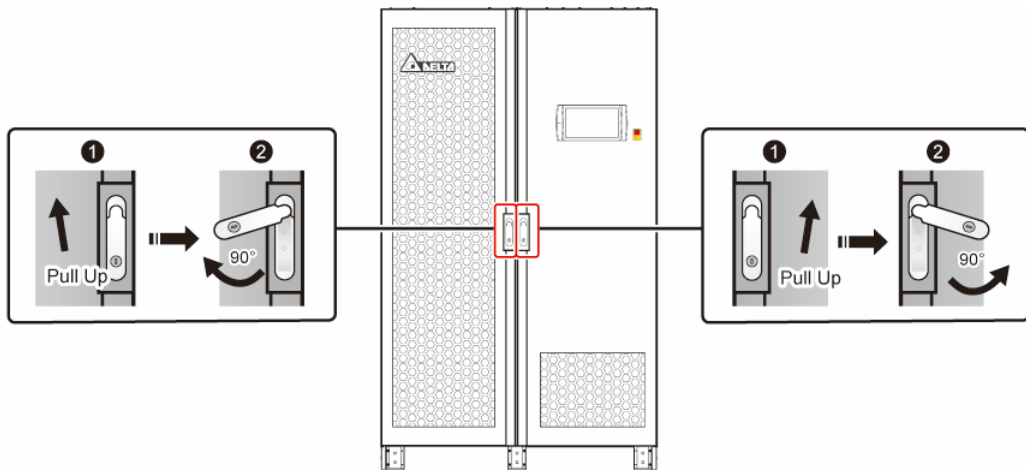

(Figure 2-6: How to Open the Front Doors of 400/ 500/ 600kVA UPS)

2.6 Internal View



WARNING:

Only authorized Delta engineers or service personnel can perform installation, wiring, panel & cover removal, maintenance and operation. If you want to execute any action mentioned above by yourself, the action must be under the supervision of authorized Delta engineers or service personnel.

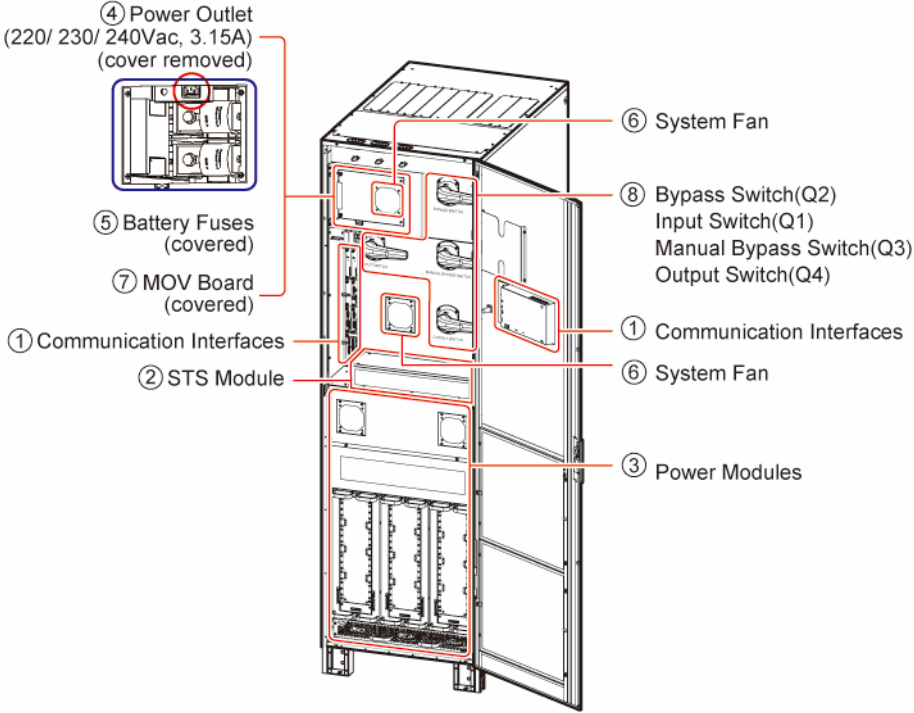

(Figure 2-7: 300kVA UPS_ Internal View)

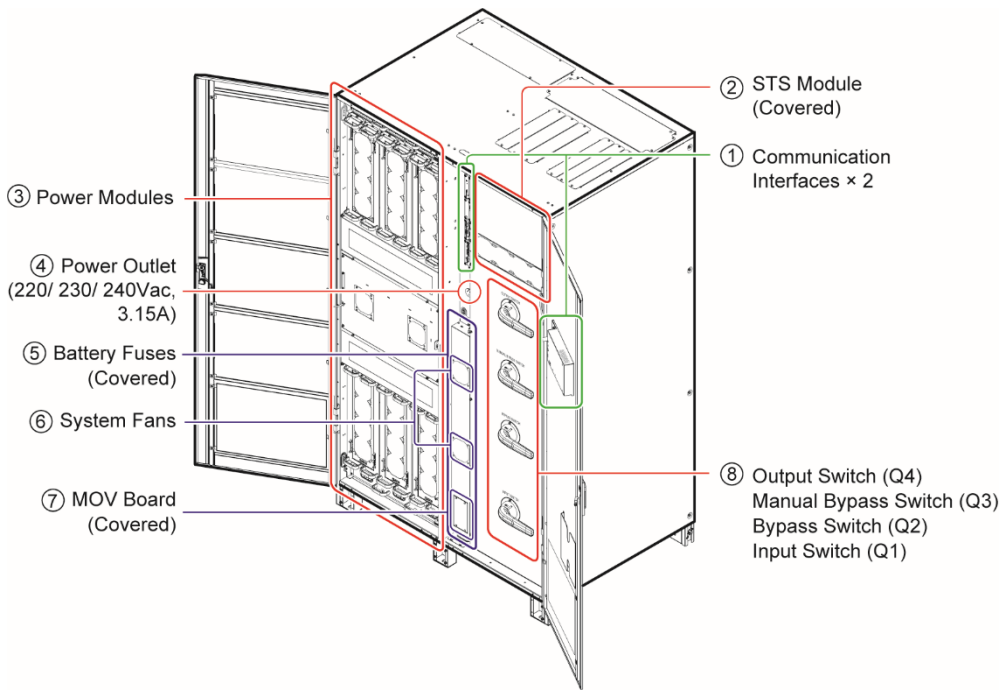

(Figure 2-8: 400/ 500/ 600 kVA UPS_ Internal View)



NOTE:

For 400, 500 and 600kVA UPS, their exteriors are the same. The main interior difference is the number of power cells. In this manual, only 600kVA UPS will be taken as an example for the 400/ 500/ 600kVA UPS.

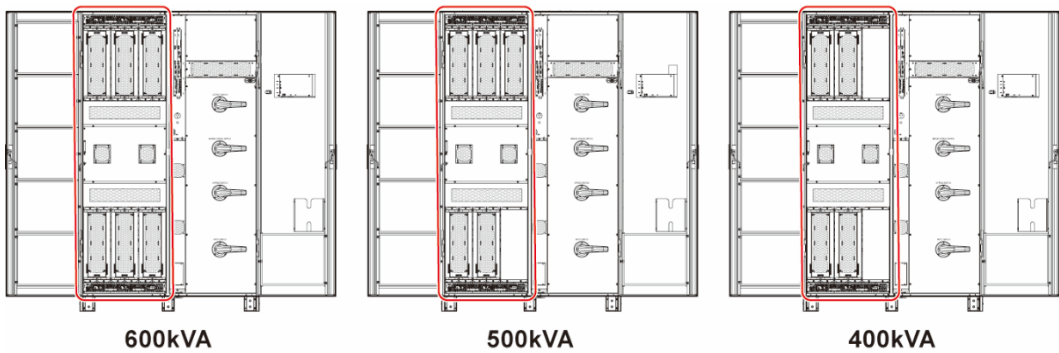

(Figure 2-9: 400/ 500/ 600 kVA UPS_ Interior Differences)

1. For detailed information about the communication interfaces, please refer to **4. Communication Interfaces**.
2. About how to turn on/ turn off the switch, please refer to **Figure 2-10**.

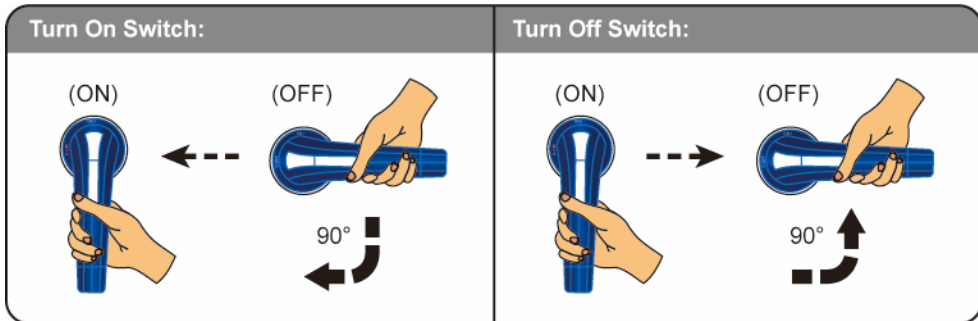

(Figure 2-10: Turn on/ off the Switch)

3. The power outlet (220/ 230/ 240Vac, 3.15A) is without galvanic isolation.



NOTE:

Only authorized Delta engineers or service personnel can use the power outlet. If you want to use the power outlet by yourself, it must be under the supervision of authorized Delta engineers or service personnel.

4. The system fans are for heat dissipation of the internal bus bars and the battery fuses.
5. To see the wiring terminals, please remove the switch panels.

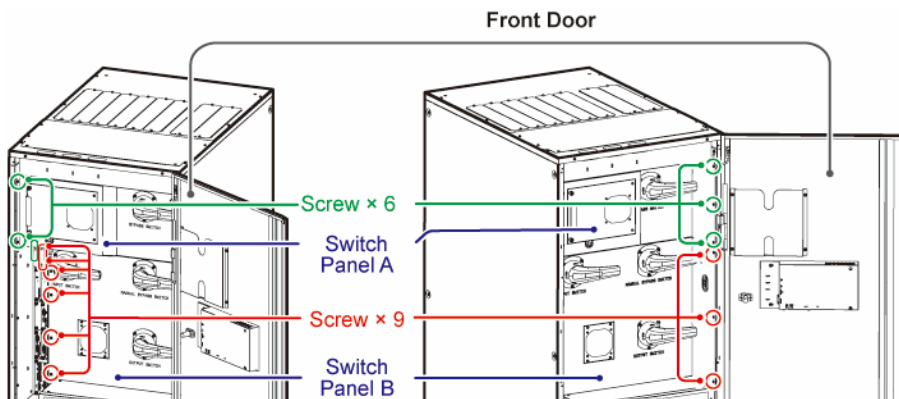

(Figure 2-11: 300kVA UPS_ Location of the Switch Panels and Screws)

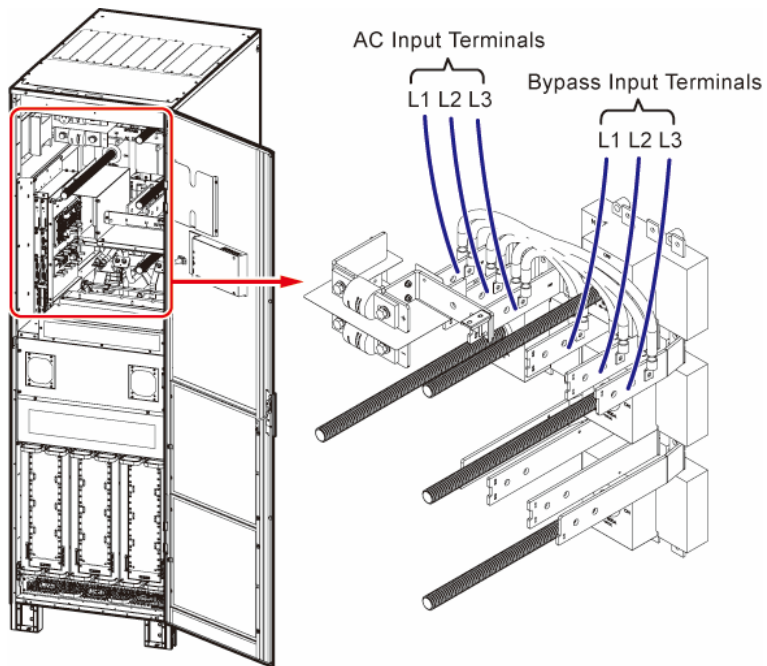

(Figure 2-12: 300kVA UPS_ AC Input Terminals & Bypass Input Terminals)

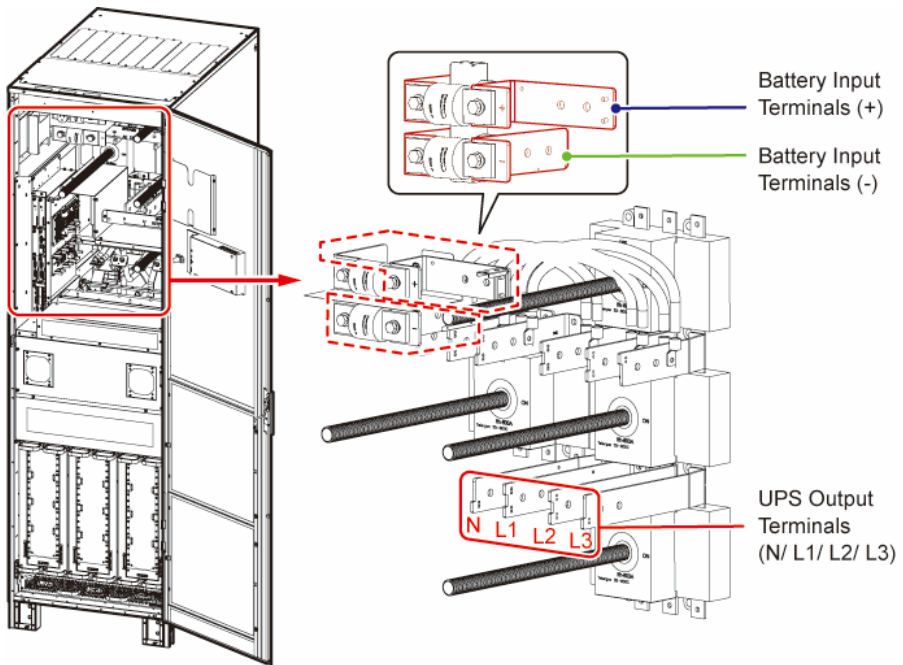

(Figure 2-13: 300kVA UPS_ UPS Output Terminals & Battery Input Terminals)

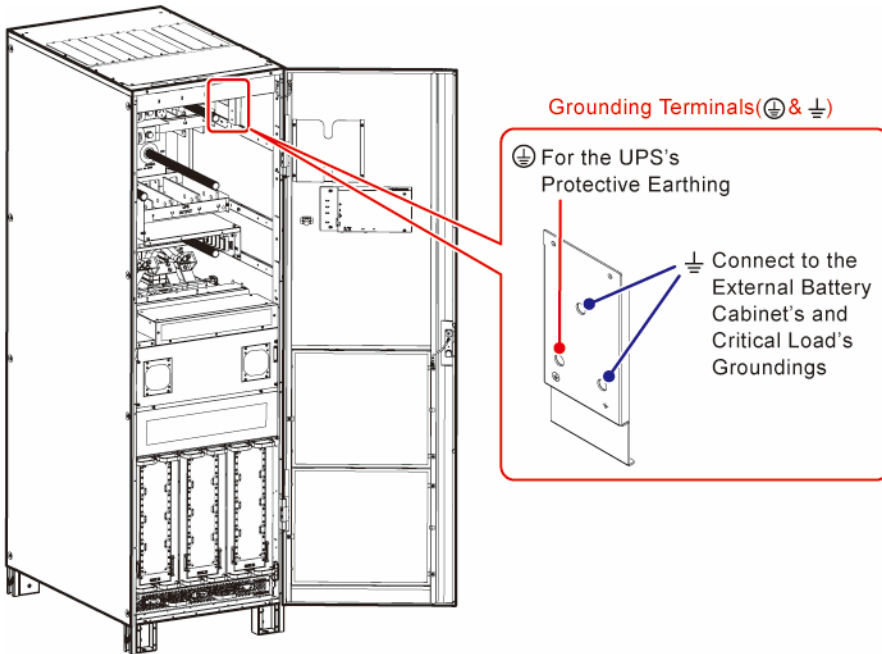

(Figure 2-14: 300kVA UPS_ Grounding Terminals)

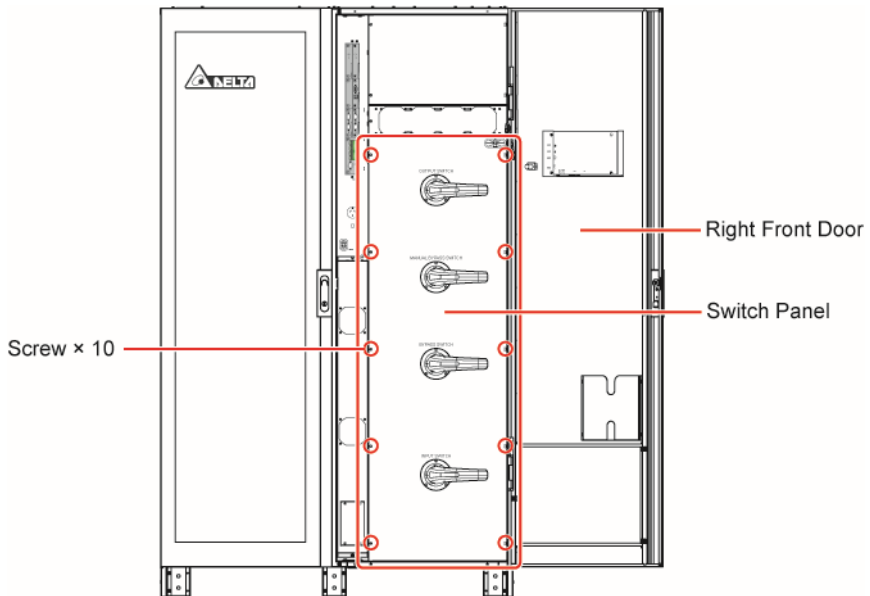

(Figure 2-15: 400/ 500/ 600kVA UPS_ Location of the Switch Panel and Screws)

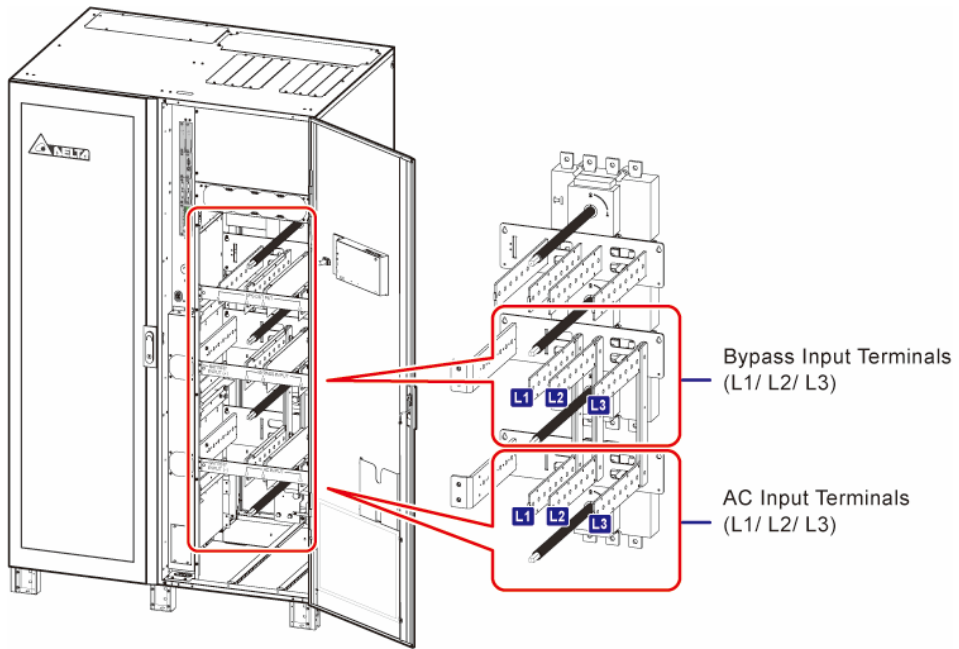

(Figure 2-16: 400/ 500/ 600kVA UPS_ AC Input Terminals & Bypass Input Terminals)

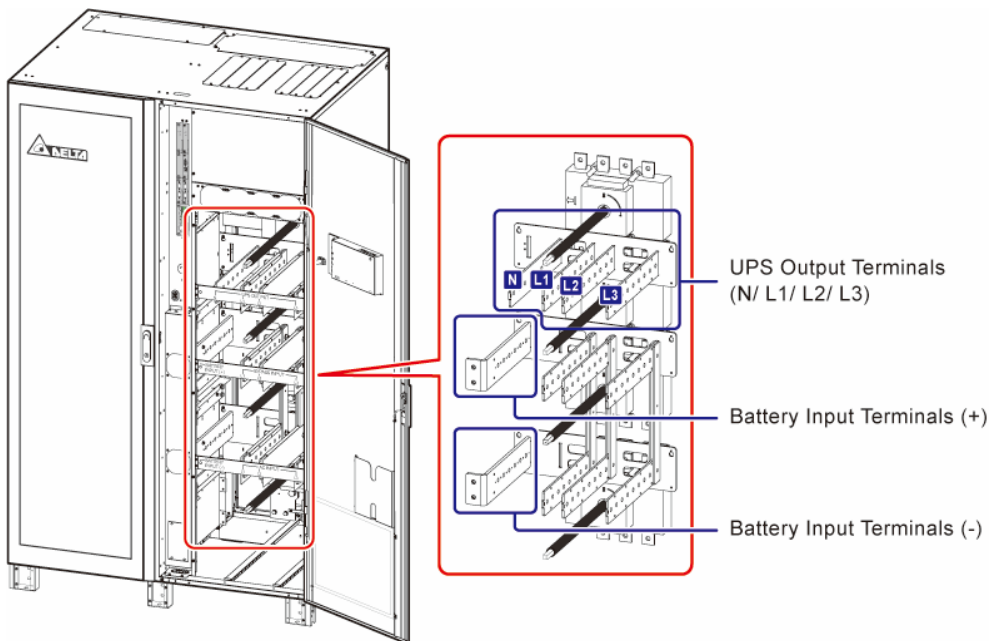

(Figure 2-17: 400/ 500/ 600kVA UPS_ UPS Output Terminals & Battery Input Terminals)

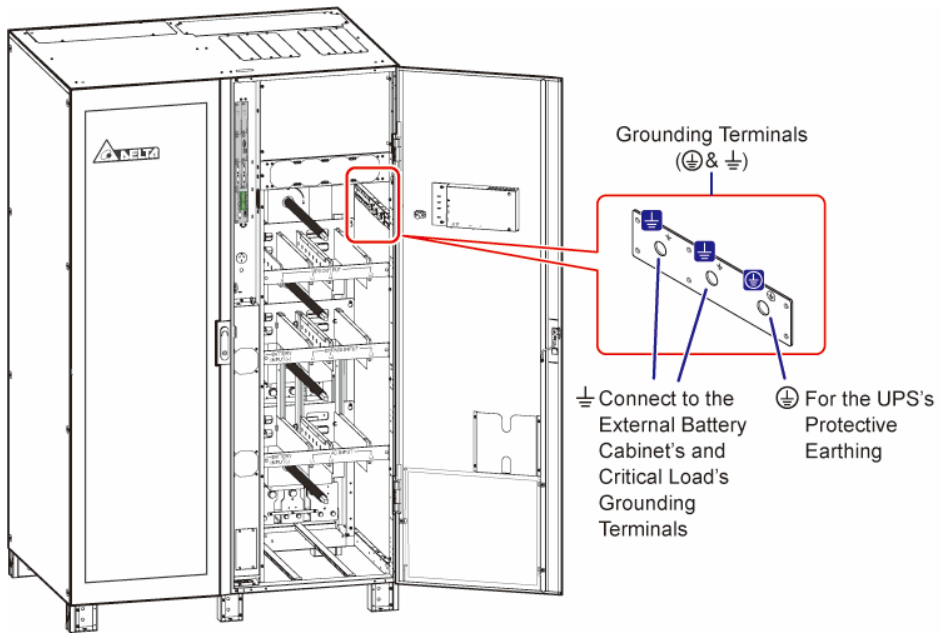

(Figure 2-18: 400/ 500/ 600kVA UPS_ Grounding Terminals)

2.7 Tri-color LED Indicator & Buzzer



(Figure 2-19: Tri-color LED Indicator Location)



NOTE:

For information about the 10" color touch panel, please refer to **7. LCD Display & Settings**.

The buzzer is located at the rear of the front door.

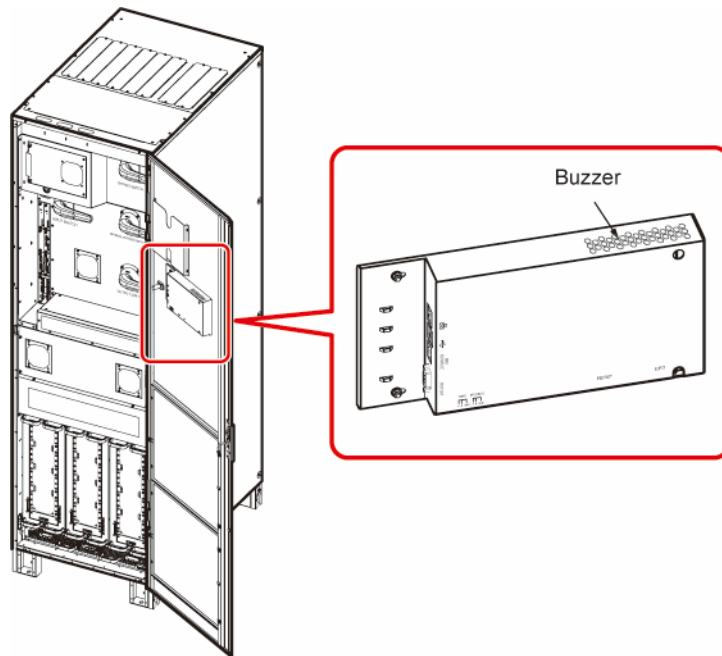

(Figure 2-20: 300kVA UPS_ Buzzer Location)

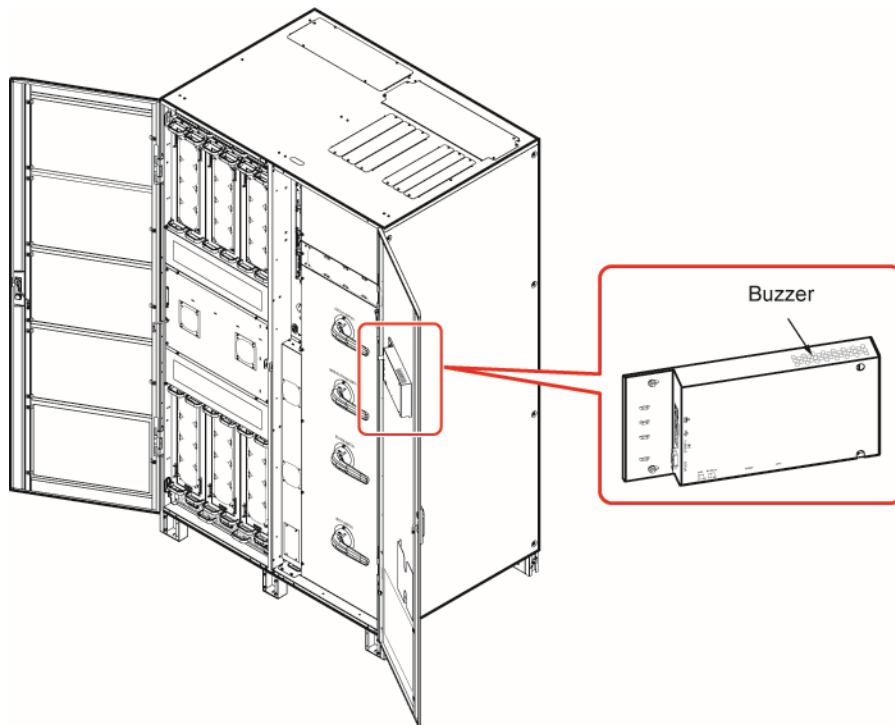

(Figure 2-21: 400/ 500/ 600kVA UPS_ Buzzer Location)

Table 2-1: Tri-color LED Indicator, UPS Operation Mode & Buzzer

Tri-color LED Indicator	Status	Meaning																
Green	ON	<ul style="list-style-type: none"> Indicates the UPS is operating in one of the following modes: <table border="1" data-bbox="550 378 1204 645"> <thead> <tr> <th data-bbox="554 384 856 459">UPS Operation Mode</th> <th data-bbox="858 384 1200 459">Text on the LCD Screen (upper-right corner)</th> </tr> </thead> <tbody> <tr> <td data-bbox="554 463 856 510">On-Line Mode</td> <td data-bbox="858 463 1200 510">'On-Line'</td> </tr> <tr> <td data-bbox="554 513 856 560">ECO Mode</td> <td data-bbox="858 513 1200 560">'ECO'</td> </tr> <tr> <td data-bbox="554 564 856 639">Frequency Conversion Mode</td> <td data-bbox="858 564 1200 639">'Frequency Conversion'</td> </tr> </tbody> </table> 	UPS Operation Mode	Text on the LCD Screen (upper-right corner)	On-Line Mode	'On-Line'	ECO Mode	'ECO'	Frequency Conversion Mode	'Frequency Conversion'								
UPS Operation Mode	Text on the LCD Screen (upper-right corner)																	
On-Line Mode	'On-Line'																	
ECO Mode	'ECO'																	
Frequency Conversion Mode	'Frequency Conversion'																	
Yellow	ON	<ul style="list-style-type: none"> Indicates the UPS is operating in one of the following modes: <table border="1" data-bbox="550 751 1204 1037"> <thead> <tr> <th data-bbox="554 757 856 832">UPS Operation Mode</th> <th data-bbox="858 757 1200 832">Text on the LCD Screen (upper-right corner)</th> </tr> </thead> <tbody> <tr> <td data-bbox="554 836 856 882">Bypass Mode</td> <td data-bbox="858 836 1200 882">'Bypass'</td> </tr> <tr> <td data-bbox="554 886 856 933">Battery Mode</td> <td data-bbox="858 886 1200 933">'Battery'</td> </tr> <tr> <td data-bbox="554 937 856 983">Standby Mode</td> <td data-bbox="858 937 1200 983">'Standby'</td> </tr> <tr> <td data-bbox="554 987 856 1033">Softstart Mode</td> <td data-bbox="858 987 1200 1033">'Softstart'</td> </tr> </tbody> </table> Indicates a warning message: <table border="1" data-bbox="550 1083 1204 1302"> <thead> <tr> <th data-bbox="554 1089 856 1136">Warning Level</th> <th data-bbox="858 1089 1200 1136">Buzzer Frequency</th> </tr> </thead> <tbody> <tr> <td data-bbox="554 1139 856 1217">Minor</td> <td data-bbox="858 1139 1200 1217">Sounds for 0.5 second every 3 seconds.</td> </tr> <tr> <td data-bbox="554 1221 856 1298">Medium</td> <td data-bbox="858 1221 1200 1298">Sounds for 0.5 second every second.</td> </tr> </tbody> </table> 	UPS Operation Mode	Text on the LCD Screen (upper-right corner)	Bypass Mode	'Bypass'	Battery Mode	'Battery'	Standby Mode	'Standby'	Softstart Mode	'Softstart'	Warning Level	Buzzer Frequency	Minor	Sounds for 0.5 second every 3 seconds.	Medium	Sounds for 0.5 second every second.
UPS Operation Mode	Text on the LCD Screen (upper-right corner)																	
Bypass Mode	'Bypass'																	
Battery Mode	'Battery'																	
Standby Mode	'Standby'																	
Softstart Mode	'Softstart'																	
Warning Level	Buzzer Frequency																	
Minor	Sounds for 0.5 second every 3 seconds.																	
Medium	Sounds for 0.5 second every second.																	
Red	ON	<ul style="list-style-type: none"> Indicates a warning message <table border="1" data-bbox="550 1369 1204 1470"> <thead> <tr> <th data-bbox="554 1375 856 1421">Warning Level</th> <th data-bbox="858 1375 1200 1421">Buzzer Frequency</th> </tr> </thead> <tbody> <tr> <td data-bbox="554 1425 856 1472">Major</td> <td data-bbox="858 1425 1200 1472">Long beep.</td> </tr> </tbody> </table> 	Warning Level	Buzzer Frequency	Major	Long beep.												
Warning Level	Buzzer Frequency																	
Major	Long beep.																	

Chapter 3 : Operation Modes

The UPS runs in six basic operation modes, which are **On-Line** mode, **Battery** mode, **Bypass** mode, **Manual Bypass** mode, **ECO** mode and **Frequency Conversion** mode.



NOTE:

1. In this user manual, Q1, Q2, Q3, Q4 and Q5 represents the following.

Code	Meaning
Q1	Input Switch
Q2	Bypass Switch
Q3	Manual Bypass Switch
Q4	Output Switch
Q5	External Battery Cabinet's Breaker

2. To enable the following operation modes, please refer to **6. UPS Operation & 7. LCD Display & Settings**.

3.1 On-Line Mode

In On-Line mode, the main AC source supplies AC power via the Input Switch (Q1) to the rectifier, and the rectifier converts the AC power to DC power and supplies the DC power to the inverter. In the meantime, the rectifier provides charging power to the batteries. After receiving the DC power, the inverter converts it into clean and stable AC power to the connected critical loads via the Output Switch (Q4). During On-Line mode, the UPS's tri-color LED illuminates green and the text '**On-Line**' appears in the upper right corner of the LCD screen.

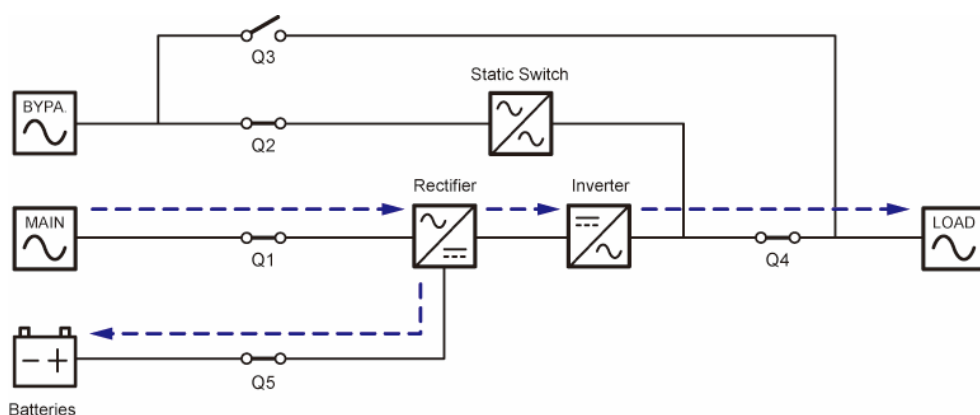

3.2 Battery Mode

The UPS transfers to Battery mode automatically if the main AC source is abnormal, for example, when unstable voltage or a power outage occurs. In Battery mode, the batteries provide DC power and the UPS converts it into AC power and supplies it to the connected critical loads via the Output Switch (Q4). During the conversion process, output voltage remains the same. During Battery mode, the UPS's tri-color LED illuminates yellow and the text 'Battery' appears in the upper right corner of the LCD screen.

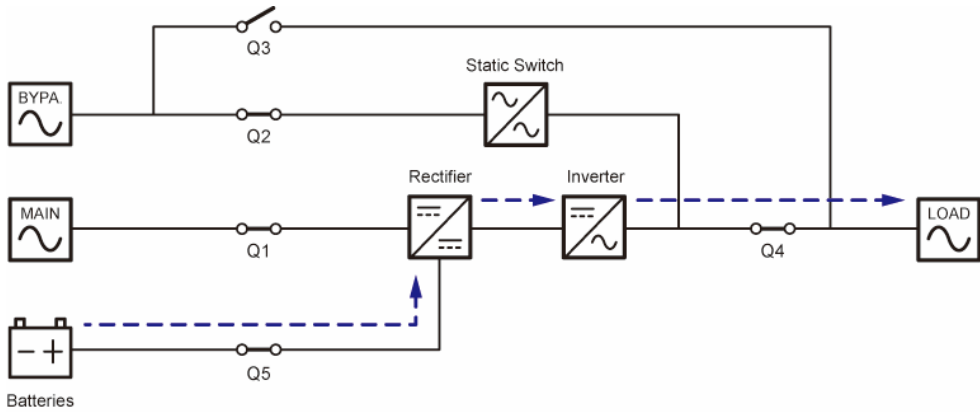

3.3 Bypass Mode

When the inverter encounters abnormal situations such as over temperature, overload, short circuit, abnormal output voltage or low battery, it will automatically shut itself down. If the UPS detects the bypass input is normal, it will automatically switch to Bypass mode to protect the connected critical loads from power interruption. After the above-mentioned abnormalities are eliminated, the UPS will switch back to On-Line mode from Bypass mode. During Bypass mode, the UPS's tri-color LED illuminates yellow and the text 'Bypass' appears in the upper right corner of the LCD screen.

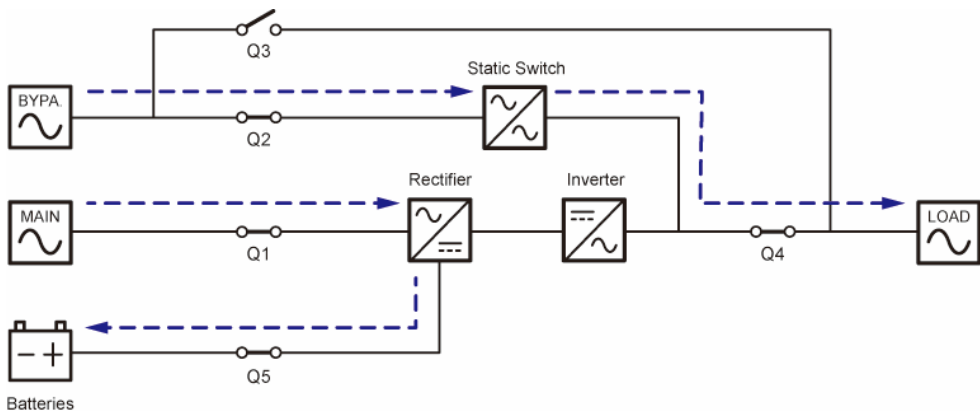

3.4 Manual Bypass Mode

When the UPS works in Manual bypass mode, the current flows through the maintenance bypass instead of the power modules so that the maintenance personnel can maintain the circuit inside the UPS. However, DO NOT touch any terminal block which may carry high-voltage electricity. During Manual Bypass mode, UPS's input power is completely cut off, and the critical loads are not protected. At the moment, the UPS's tri-color LED and LCD screen are both off.

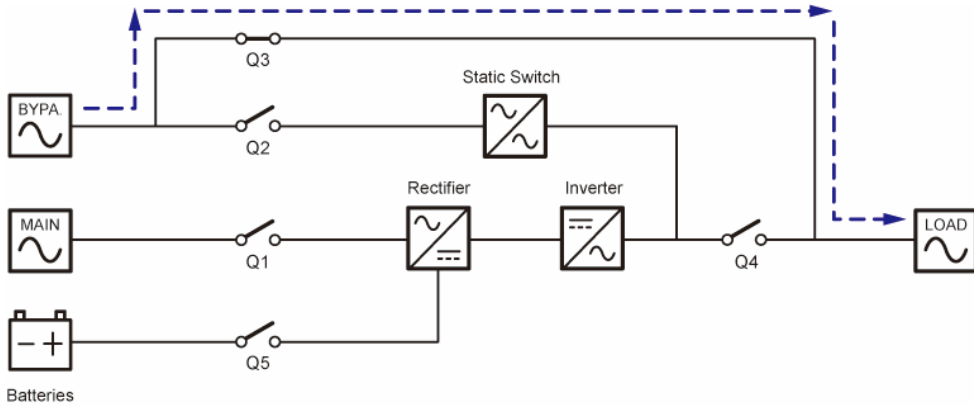

3.5 ECO Mode

After the UPS is manually set as ECO mode via the LCD, the UPS will work in Bypass mode if bypass input voltage and frequency are within $\pm 10\%$ of the rated voltage and $\pm 3\text{Hz}$ of the rated frequency respectively. Otherwise, the UPS will run in On-Line mode. During ECO mode, the UPS's tri-color LED illuminates green and the text 'ECO' appears in the upper right corner of the LCD screen.

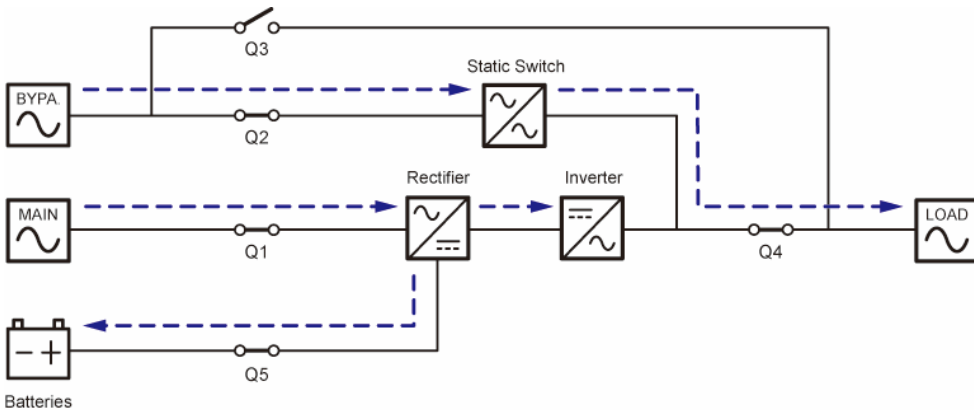

3.6 Frequency Conversion Mode



NOTE:

Frequency Conversion mode is only applicable to single UPS but not to parallel UPSs.

After the UPS is manually set as Frequency Conversion mode via the LCD, the inverter will automatically select 50Hz or 60Hz as the fixed output frequency. After the output frequency is determined, the system will automatically disable the bypass function. Please note that, once the inverter shuts down, there is no bypass output. During Frequency Conversion mode, the UPS's tri-color LED illuminates green and the text '**Frequency Conversion**' appears in the upper right corner of the LCD screen.

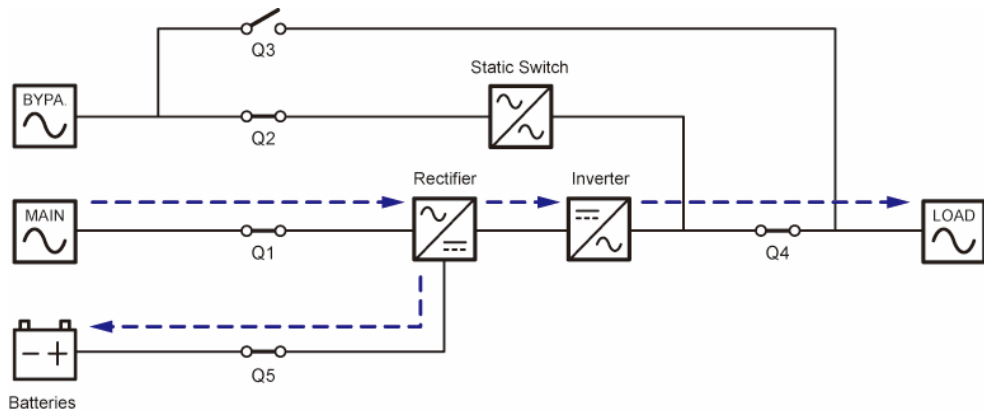

Chapter 4 : Communication Interfaces

The communication interfaces are hot-swappable and located at two different places. One is on the front of the UPS with the front door open and the other is at the rear of the touch panel. See **Figure 2-7** and **Figure 2-8** for their positions.

4.1 Communication Interfaces I: on the Front of the UPS with the Front Door Open

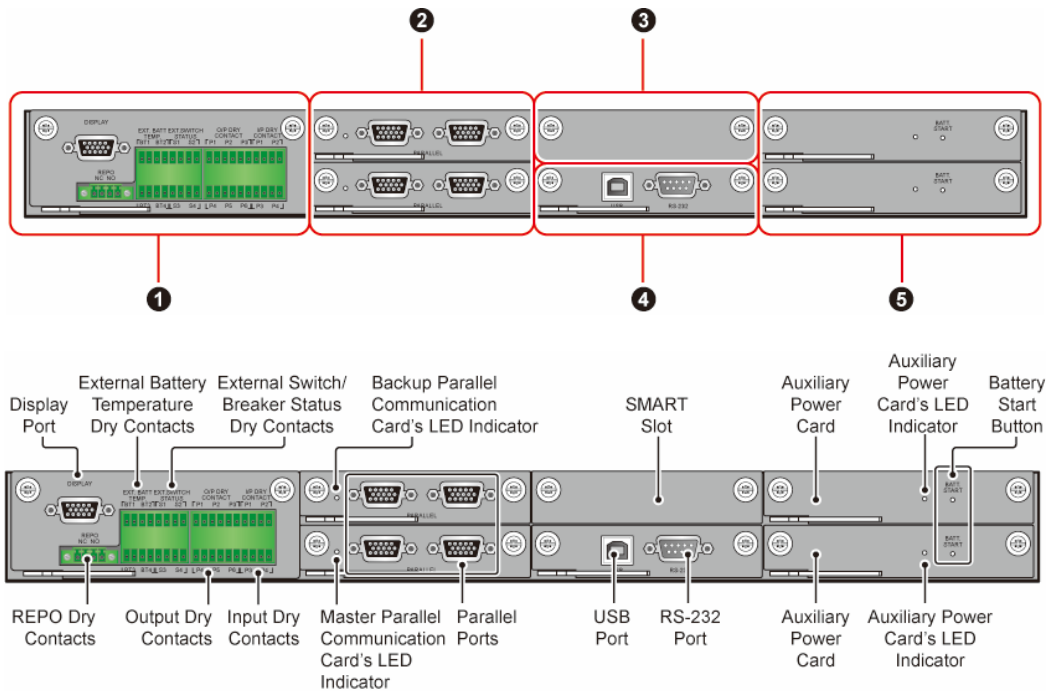

(Figure 4-1: Communication Interfaces I)

No.	Item	Q'ty
1	Dry Contact Card	1 PC
2	Parallel Communication Card	2 PCS
3	SMART Slot	1 PC
4	System Control Card	1 PC
5	Auxiliary Power Card	2 PCS

4.1.1 Display Port

Before shipment, the display port has been connected to the 10" touch panel with the designated cable in Delta factory.

4.1.2 REPO Dry Contacts

Connect the REPO dry contacts to a user-supplied switch and you can remotely shut down the UPS when an emergency occurs. The REPO dry contacts provide normally open (NO) and normally closed (NC) these two options for use.

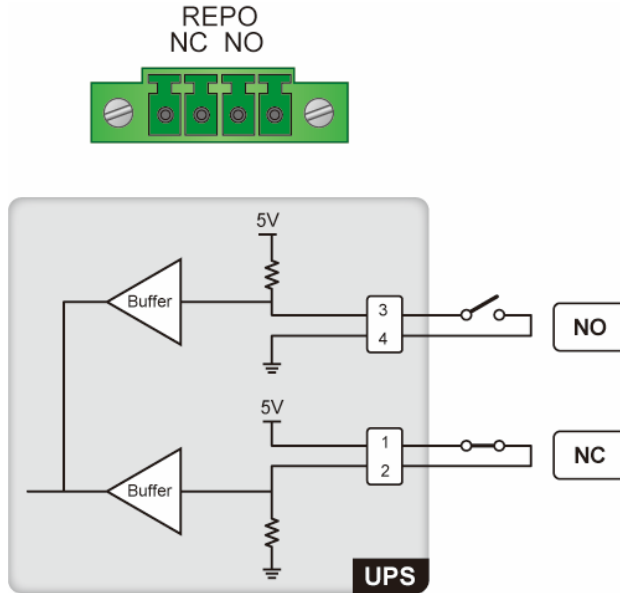

(Figure 4-2: REPO Dry Contacts & Schematic)



NOTE:

To enable the normally closed (NC) function, please take out the dry contact card and remove its Jump CNR3 before you turn on the UPS.

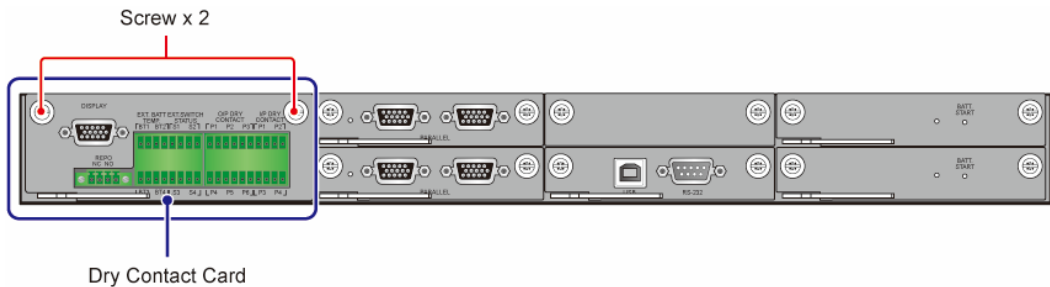

(Figure 4-3: Location of the Dry Contact Card)

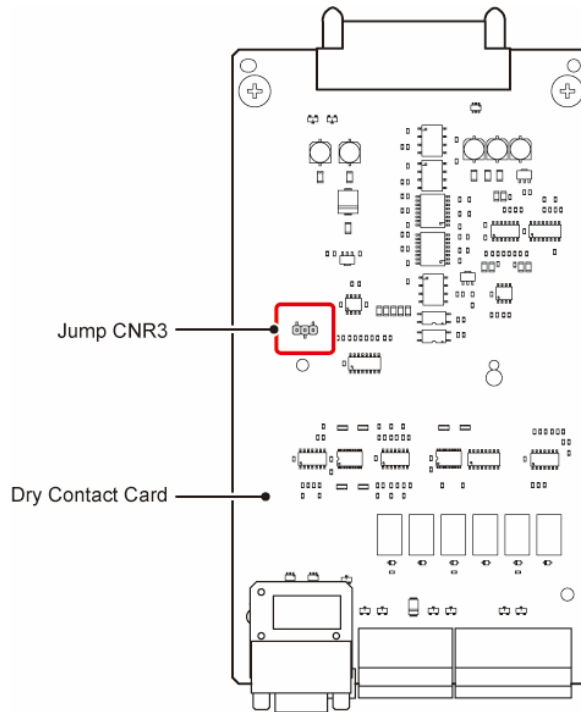

(Figure 4-4: Location of the Jump CNR3)

For connection to the REPO dry contacts (and other dry contacts on the communication interfaces I), please follow the instructions below to route the signal cable (user-supplied).



NOTE:

1. In accordance with National Electrical Codes (NEC), please install a suitable conduit and bushing for cable protection.
2. Please refer to national and local electrical codes for the acceptable cable size.
3. For top entry, please remove the knockout cover(s) at the top of the UPS before performing the steps below.

● **300kVA UPS_ Signal Cable Routing Method (Top Entry Only)**

Step 1

Install the snap bushing(s). There are three cable entrances that you can choose to use. The snap bushings are provided in the accessory package.

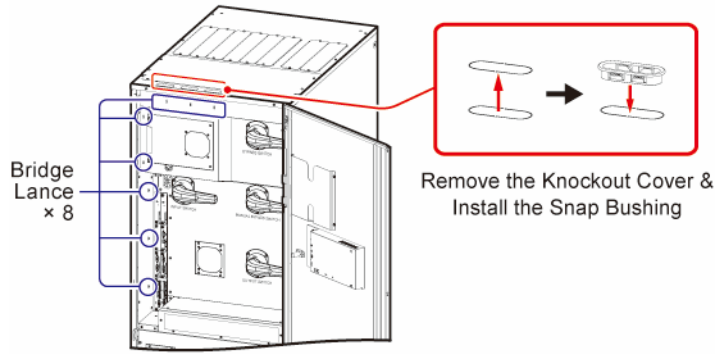

(Figure 4-5: 300kVA UPS_ Signal Cable Routing-1)

Step 2

Refer to instructions ① ~ ④ below to properly route and secure the signal cable with cable ties (user-supplied). There are eight bridge lances that you can choose to use.

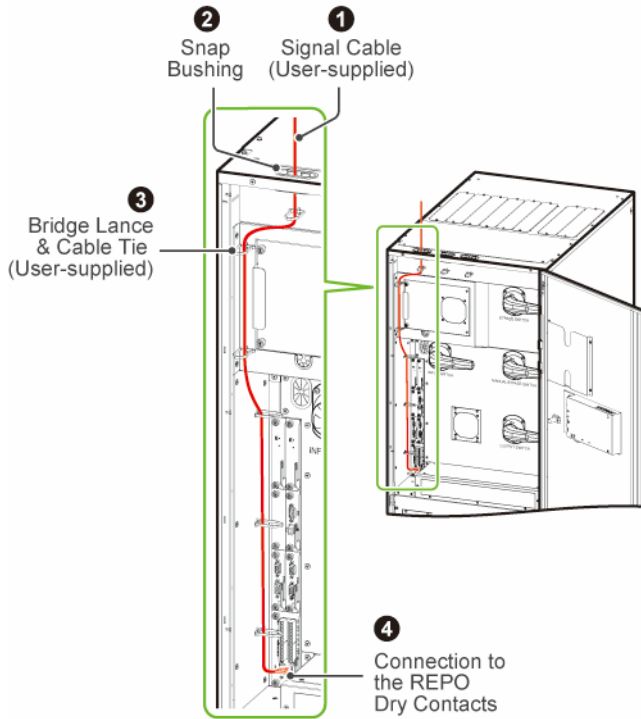

(Figure 4-6: 300kVA UPS_ Signal Cable Routing-2)

- **400/ 500/ 600kVA UPS_ Signal Cable Routing Method (Top & Bottom Entry)**

Step 1

For top entry, use the snap bushing, wire mounts and M4 screws in the accessory package to install the snap bushing and fasten the wire mounts on the frame.

For bottom entry, use the wire mounts and M4 screws in the accessory package to fasten the wire mounts on the frame.

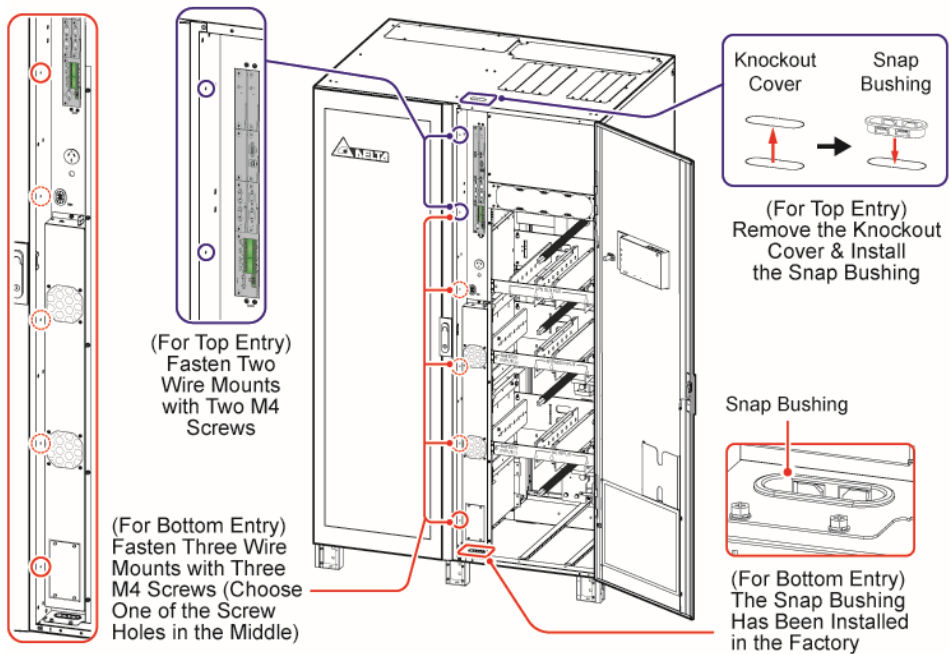

(Figure 4-7: 400/ 500/ 600kVA UPS_ Signal Cable Routing-1)

Step 2

For top/ bottom entry, route the user-supplied signal cable (①) through the snap bushing (②), use a cable tie (user-supplied) for each wire mount (③) to fix the signal cable on the frame, and connect the signal cable to the REPO dry contacts (④).



NOTE:

The number of the wire mounts and cable ties shown in the figures are for reference only. The actual number depends on your on-site application.

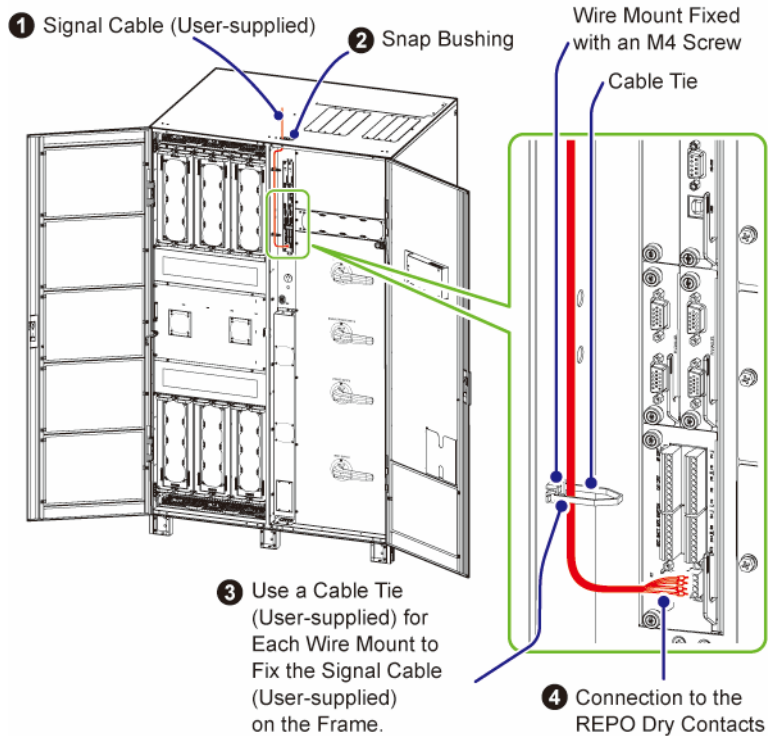

(Figure 4-8: 400/ 500/ 600kVA UPS_ Signal Cable Routing-2_ Top Entry)

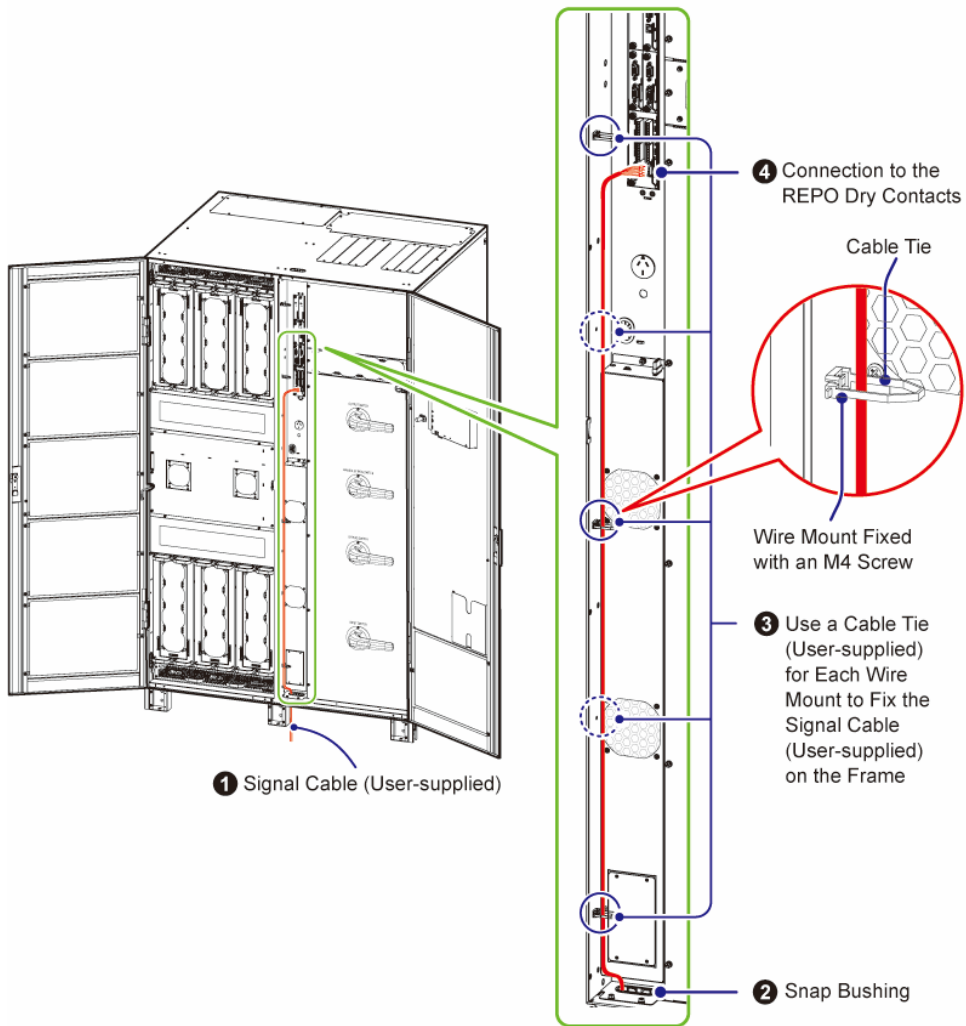

(Figure 4-9: 400/ 500/ 600kVA UPS_ Signal Cable Routing-2_ Bottom Entry)

4.1.3 External Battery Temperature Dry Contacts

You can use the external battery temperature dry contacts (BT1, BT2, BT3 and BT4) to detect at maximum four external battery cabinets' temperatures. You need to purchase the battery cabinet temperature sensor cable (optional).

For connection to the external battery temperature dry contacts, the signal cable routing is the same as the REPO dry contacts' signal cable routing.

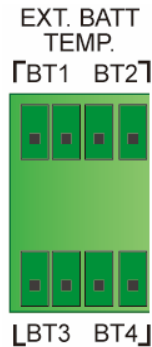

(Figure 4-10: External Battery Temperature Dry Contacts)

4.1.4 External Switch/ Breaker Status Dry Contacts

There are four sets of external switch/ breaker status dry contacts (S1, S2, S3 and S4), which can be used to respectively detect the status of input, bypass, output and manual bypass switches or breakers.

For connection to the external switch/ breaker status dry contacts, the signal cable routing is the same as the REPO dry contacts' signal cable routing.



NOTE:

Only trained Delta engineers can enable the function. Please contact Delta customer service for implementation.

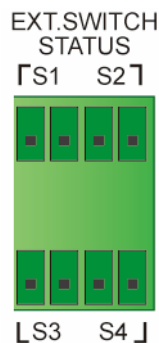

(Figure 4-11: External Switch/ Breaker Status Dry Contacts)

4.1.5 Output Dry Contacts

There are six sets of programmable output dry contacts. Please use the touch panel to set each dry contact as normally open (NO) or normally closed (NC). Each dry contact can be assigned a specific event. Six out of twenty-one events can be assigned according to your applications. Please refer to the table below and **7.6.6 Dry Contact Setting**.

For connection to the output dry contacts, the signal cable routing is the same as the REPO dry contacts' signal cable routing.



NOTE:

Since the output dry contacts belong to the secondary circuit, the voltage of each dry contact's connected device should not exceed 60Vdc/ 42Vac to avoid electric shock or insufficient insulation.

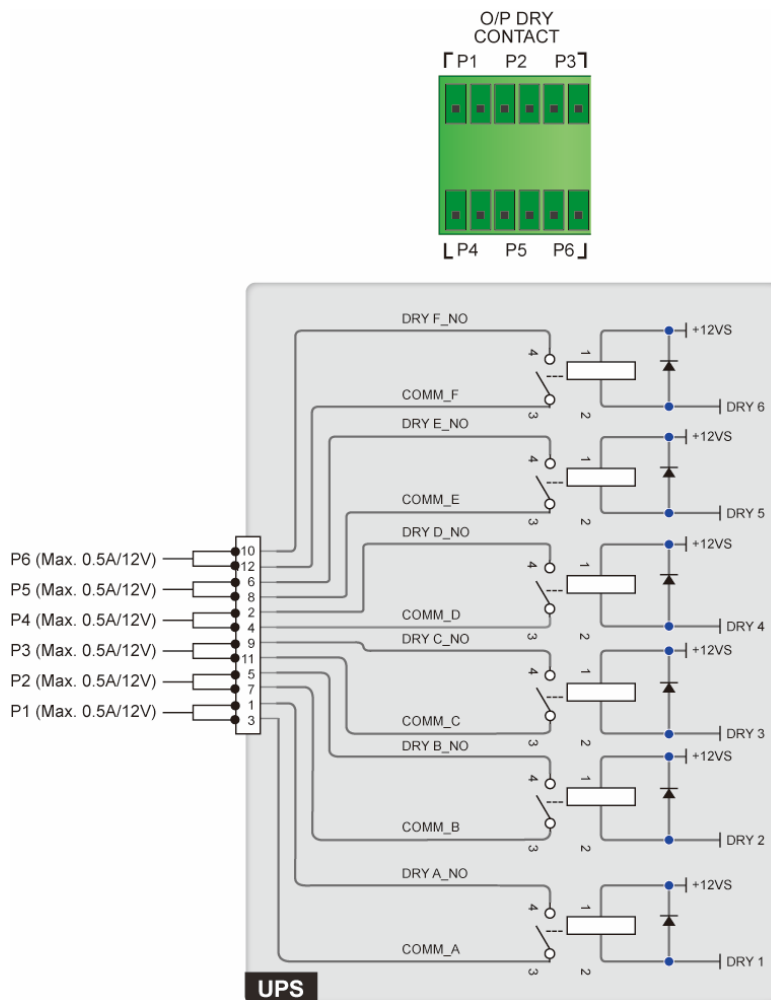

(Figure 4-12: Output Dry Contacts & Schematic)

No.	Event	Description
1	None	No set-up.
2	Load On Inverter	The UPS works in On-Line mode.
3	Load On Bypass	The UPS works in Bypass mode.
4	Load On Battery	When the main AC source fails, the batteries supply power to the critical loads.
5	Battery Low	When the UPS runs in Battery mode, battery voltage is lower than the setup limit (default: 220Vdc).
6	Bypass Input Abnormal	The bypass voltage, frequency or phase sequence is abnormal.
7	Battery Test Fail	During the battery test, the battery voltage is out of the setup limit.
8	Internal Comm. Fail	The #n power module's internal communication is abnormal.
9	External Parallel Comm. Fail (For parallel application only)	In parallel mode, parallel communication is abnormal.
10	Output Overload	The UPS is overloaded or the UPS shuts down to let the bypass supply power to the critical loads.
11	EPO Activated	The EPO button is pressed to urgently power off the UPS.
12	Load On Manual Bypass	The Manual Bypass Switch (Q3) is turned on and the UPS transfers to Manual Bypass mode.
13	Battery Over Temperature	The external battery cabinet's temperature is too high.
14	Output Voltage Abnormal	The output voltage is abnormal.
15	Battery Need Replacement	The battery replacement date is due.
16	Bypass Over Temperature	The bypass static switch temperature is too high.
17	Bypass Static Switch Fault	The bypass static switch has an open/ short issue.
18	UPS Over Temperature	The UPS temperature is too high.

No.	Event	Description
19	Battery Breaker Shunt Trip	When the EPO button is pressed, the UPS will send a signal to the connected external shunt trip device to cut off the battery power.
20	Backfeed Protection	When the UPS's bypass SCR has a short-circuit issue, the UPS will send a signal to the connected external shunt trip device to cut off the backfeed voltage.
21	General Alarm	When any UPS alarm occurs, the UPS will send a signal.

4.1.6 Input Dry Contacts

There are four sets of programmable input dry contacts. The input dry contacts allow the UPS to receive external signals from peripheral devices and let the UPS response accordingly. Please use the touch panel to set each dry contact as normally open (NO) or normally closed (NC). Each input dry contact can be assigned a specific event. Four out of ten events can be assigned according to your applications. Please refer to the table below and **7.6.6 Dry Contact Setting**.

For connection to the input dry contacts, the signal cable routing is the same as the REPO dry contacts' signal cable routing.

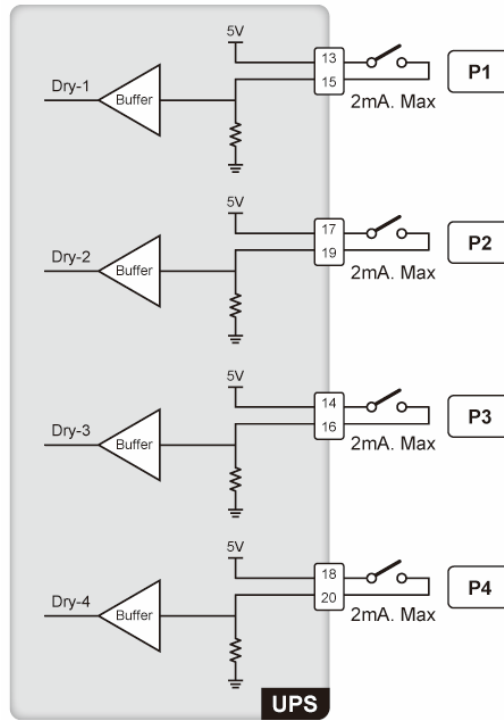

(Figure 4-13: Input Dry Contacts & Schematic)

No.	Event	Description
1	None	No set-up.
2	Generator Status	Generator status detection.
3	Battery Ground Fail	Battery leakage detection.
4	External Battery Breaker Detection	Status detection of the external battery cabinet's breaker or switch.
5	Charger Off (Positive)* ¹	Turn off the charger (positive).
6	Charger Off (Negative)* ¹	Turn off the charger (negative).
7	Battery Abnormal Shutdown	In On-Line mode: the UPS will issue battery abnormal warning. In Battery mode: the UPS will turn to Bypass or Standby mode immediately.
8	Input Transformer OTW	Input transformer over temperature warning.
9	Output Transformer OTW	Output transformer over temperature warning.
10	Battery Fuse Open	The battery fuse is blown.



NOTE:

*¹ If you use non-Delta lithium-ion batteries, you must set up **Charger Off (Positive)** and **Charger Off (Negative)** these two items. Please refer to **7.6.6 Dry Contact Setting**. For settings relevant to the non-Delta lithium-ion batteries, please refer to **7.6.4 Battery & Charging Setting**. For more information, please contact Delta customer service.

4.1.7 Parallel Communication Cards

The UPS has two parallel communication cards, which are master parallel communication card and backup parallel communication card. Each card has one LED indicator and two parallel ports.

If both cards work normally, the master parallel communication card's LED indicator will illuminate green and the backup parallel communication card's LED indicator will illuminate yellow.

If one card works normally and the other works abnormally, the normal card's LED indicator will illuminate green and the abnormal card's LED indicator will illuminate red.

During the initialization process, both cards' LED indicators flash yellow.

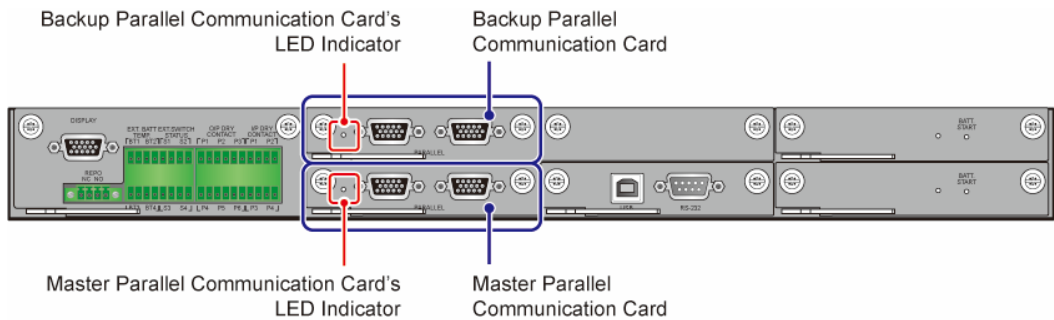

(Figure 4-14: Location of the Parallel Communication Cards)

4.1.8 Parallel Ports

The parallel ports are used to connect parallel UPSs to increase system capacity and redundancy. With the provided parallel cables, up to eight UPS units with the same capacity, voltage, frequency and version can be paralleled. Please only use the provided parallel cables and adopt Daisy Chain method to parallel the UPS units.

Please refer to **5.4.5 Parallel Unit Wiring** to route the parallel cables.



WARNING:

One parallel cable is provided in each UPS's accessory package. Using other cables to parallel the UPSs may cause failure, malfunctions and accidents.

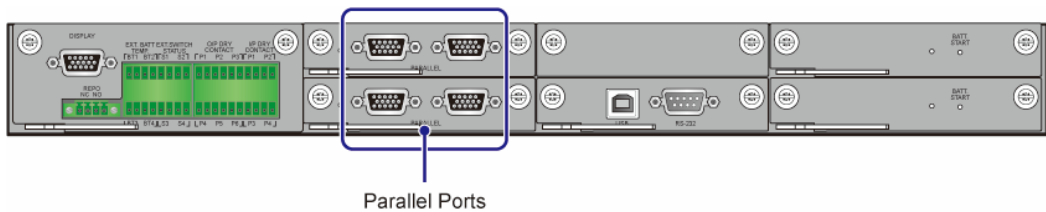

(Figure 4-15: Location of the Parallel Ports)

4.1.9 SMART Slot

1. You can install the optional relay I/O card (for dry contact expansion) into the SMART slot. For installation and application, please contact Delta customer service.

For connection to the relay I/O card's dry contacts, the signal cable routing is the same as the REPO dry contacts' signal cable routing.

2. If you use the Delta lithium-ion batteries, you must install the optional multifunctional communication card (MFC) into the SMART slot to monitor the battery status. For settings and information relevant to the Delta lithium-ion batteries, please refer to **7.6.4 Battery & Charging Setting** and **8. Optional Accessories**. For more information, please contact Delta customer service.

For connection to the MFC parallel ports, the Ethernet cable*¹ routing is the same as the UPS parallel cable routing.



NOTE:

*1 One Ethernet cable is provided in each package of the optional multi-functional communication card (MFC).

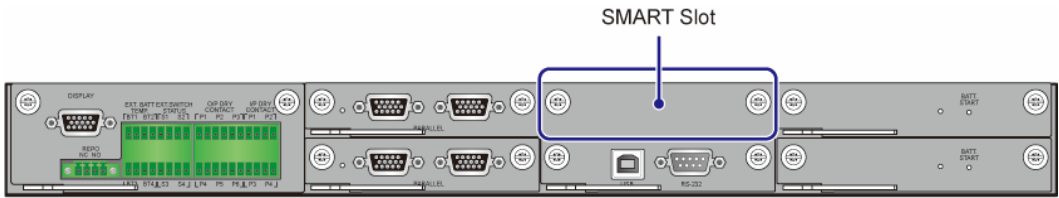

(Figure 4-16: Location of the SMART Slot)

4.1.10 USB Port & RS-232 Port

Use an RS-232 cable (not provided) or a USB cable (provided) to connect a computer to the UPS's RS-232 port or USB port, and you can (1) upgrade the firmware of the UPS, power modules, system control card, parallel communication cards and optional multifunctional communication card (MFC) and (2) download event logs.



NOTE:

Do not use the RS-232 port and the USB port at the same time.

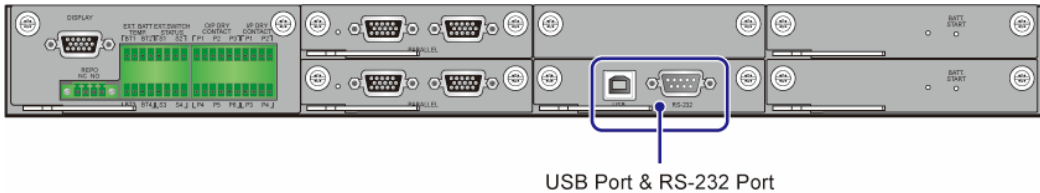

(Figure 4-17: Location of the USB Port & RS-232 Port)

4.1.11 Auxiliary Power Cards

The UPS has two hot-swappable auxiliary power cards. Each card has one LED indicator. If the auxiliary power card works normally, its LED indicator will illuminate green. If the auxiliary power card is off or abnormal, its LED indicator will be off.



WARNING:

You can only remove one card at a time for a replacement to avoid power interruption.

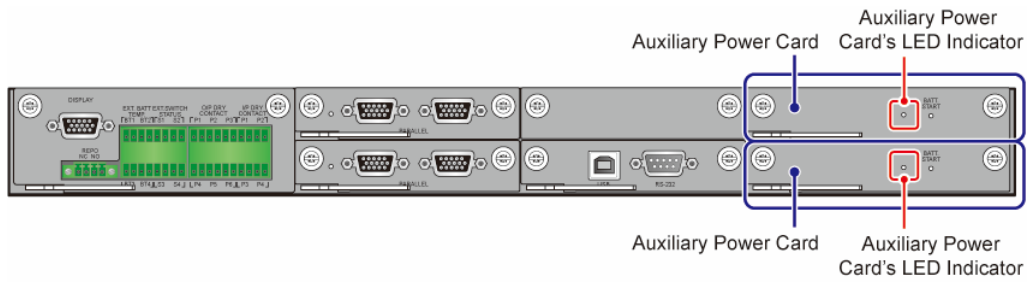

(Figure 4-18: Location of the Auxiliary Power Cards)

4.1.12 Battery Start Buttons

For the battery start buttons' operation information, please refer to **6.2.2 Battery Mode Start-up Procedures**.

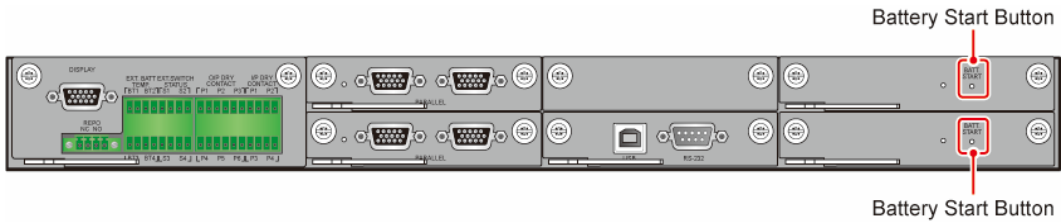

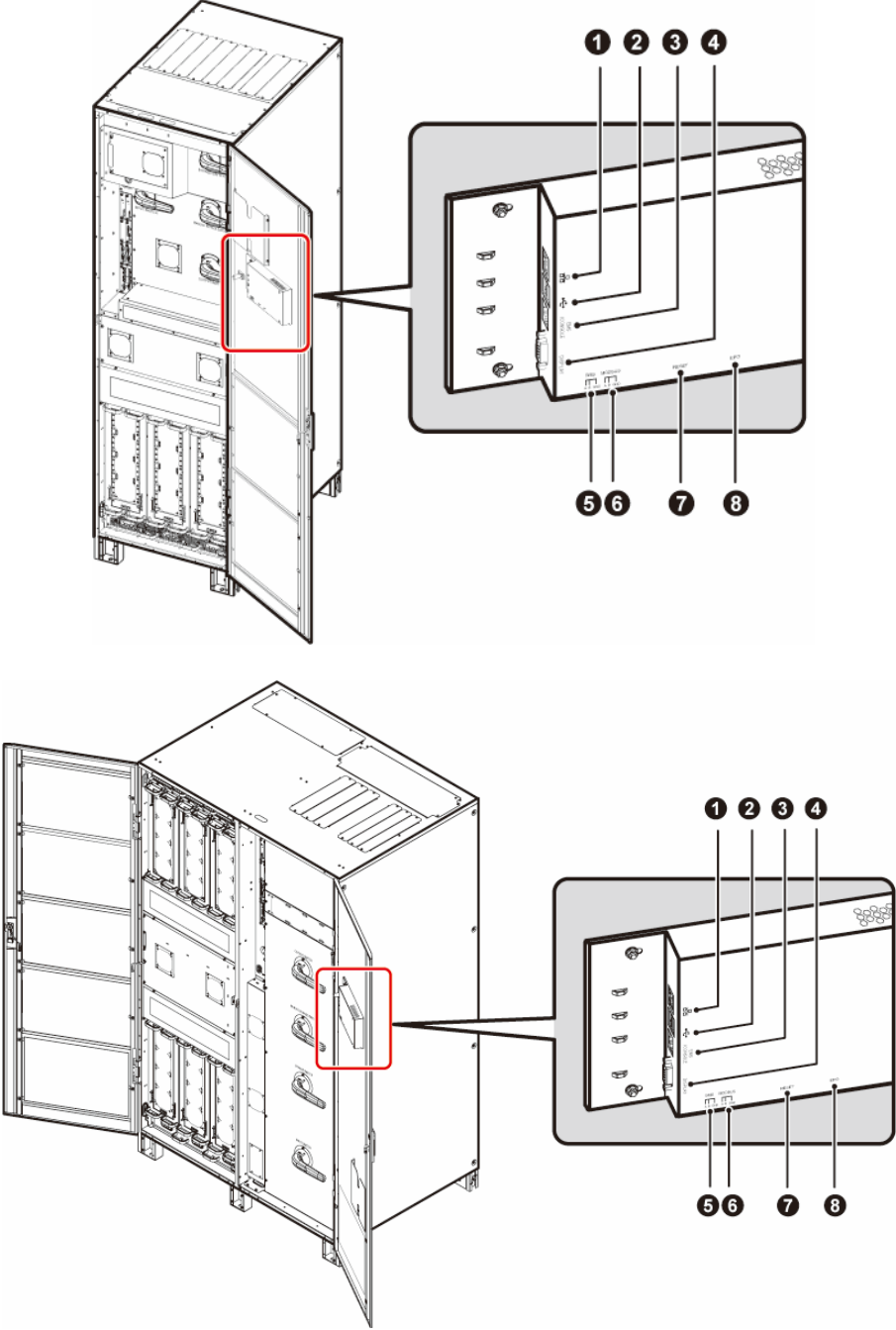

(Figure 4-19: Location of the Battery Start Buttons)

4.2 Communication Interfaces II: at the Rear of the Touch Panel



(Figure 4-20: Communication Interfaces II)

No.	Item	Description
1	 (Network Port)	1. Provides SNMP communication service. 2. Connects to a user-supplied monitoring system.
2	 (USB Port × 2)	There are two USB ports. Connect a user-supplied USB flash drive to the USB ports to (1) upgrade the UPS and LCD's firmware and (2) download event logs.
3	EMS/ CONSOLE	Connects to a user-supplied environmental monitoring system or Delta EnviroProbe 1000 (optional).
4	DISPLAY	Before shipment, the DISPLAY port has been connected.
5	BMS	Connects to the Delta battery management system (optional). The BMS function is only applicable to lead-acid batteries.
6	MODBUS	1. Provides MODBUS communication service. 2. Connects to a user-supplied monitoring system.
7	RESET	Press the RESET button to restart the LCD.
8	EPO	Before shipment, the EPO button on the front of the UPS has been connected to the EPO port.

Please follow the instructions below to route the user-supplied signal cables. The signal cable routing of the network port () is taken as an example.



NOTE:

1. In accordance with National Electrical Codes (NEC), please install a suitable conduit and bushing for cable protection.
2. Please refer to national and local electrical codes for the acceptable cable sizes.
3. For top entry, please remove the knockout cover(s) at the top of the UPS before performing the steps below.

● **300kVA UPS_ Signal Cable Routing Method (Top Entry Only)**

Step 1

Install the snap bushing(s). See **Figure 4-5**. There are three cable entrances that you can choose to use. The snap bushings are provided in the accessory package.

Step 2

Refer to instructions **① ~ ⑥** below to properly route and secure the signal cable with cable ties (user-supplied). There are eight bridge lances that you can choose to use.

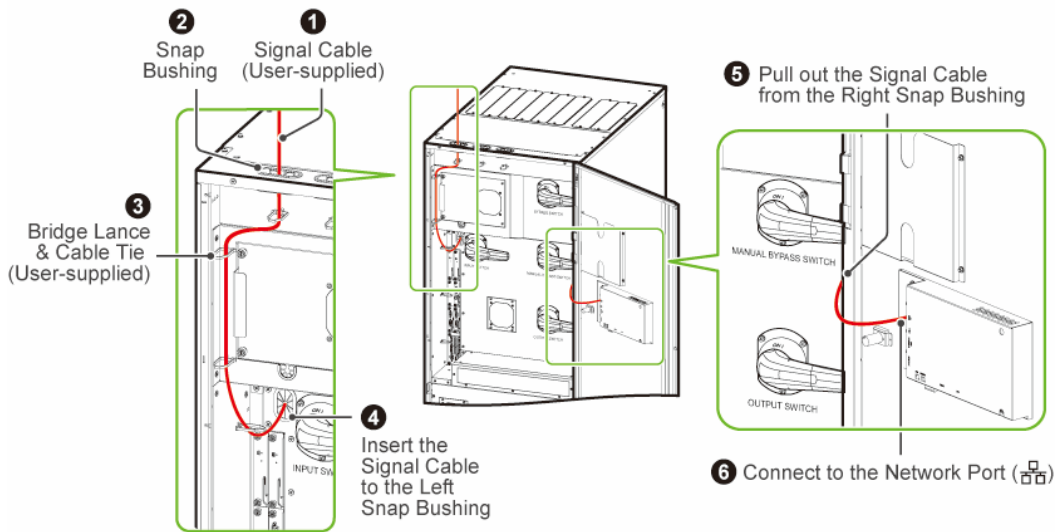

(Figure 4-21: 300kVA UPS_ Signal Cable Routing)

- **400/ 500/ 600kVA UPS_ Signal Cable Routing Method (Top & Bottom Entry)**

Step 1

For top entry, use the snap bushing, wire mounts and M4 screws in the accessory package to install the snap bushing and the wire mounts on the frame. See **Figure 4-7**

For bottom entry, use the wire mounts and M4 screws in the accessory package to install the wire mounts on the frame. See **Figure 4-7**

Step 2

For top/ bottom entry, refer to instructions ① ~ ⑥ below to properly route and secure the signal cable with cable ties (user-supplied).



NOTE:

The number of the wire mounts and cable ties shown in the figures are for reference only. The actual number depends on your on-site application.

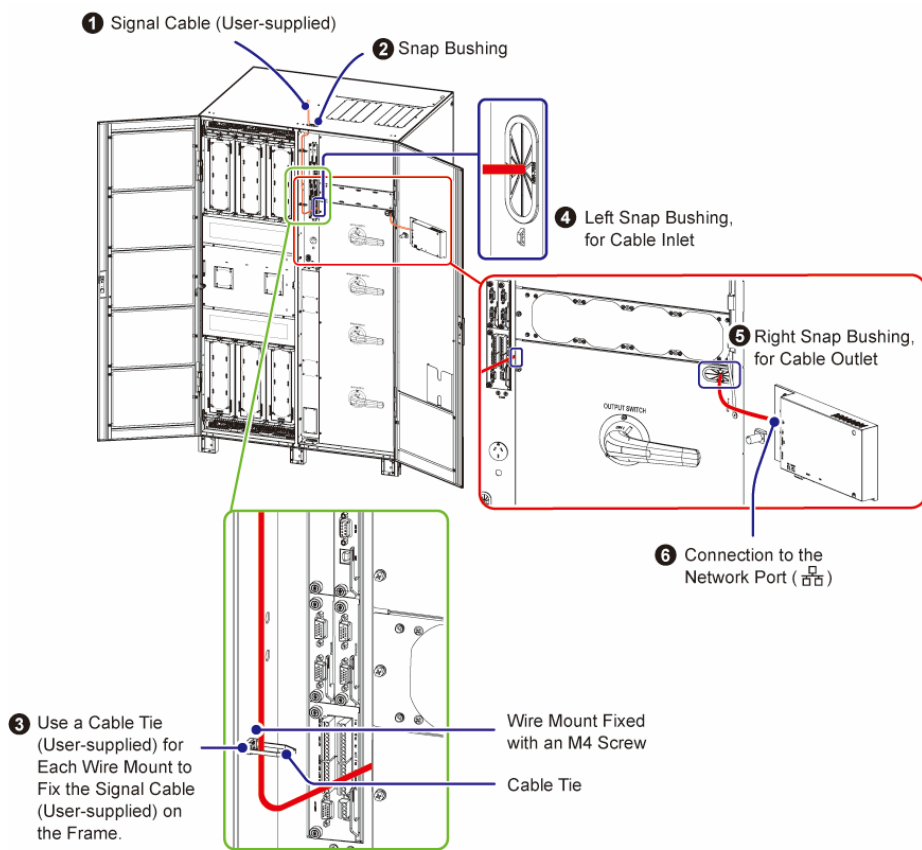

(Figure 4-22: 400/ 500/ 600kVA UPS_ Signal Cable Routing_ Top Entry)

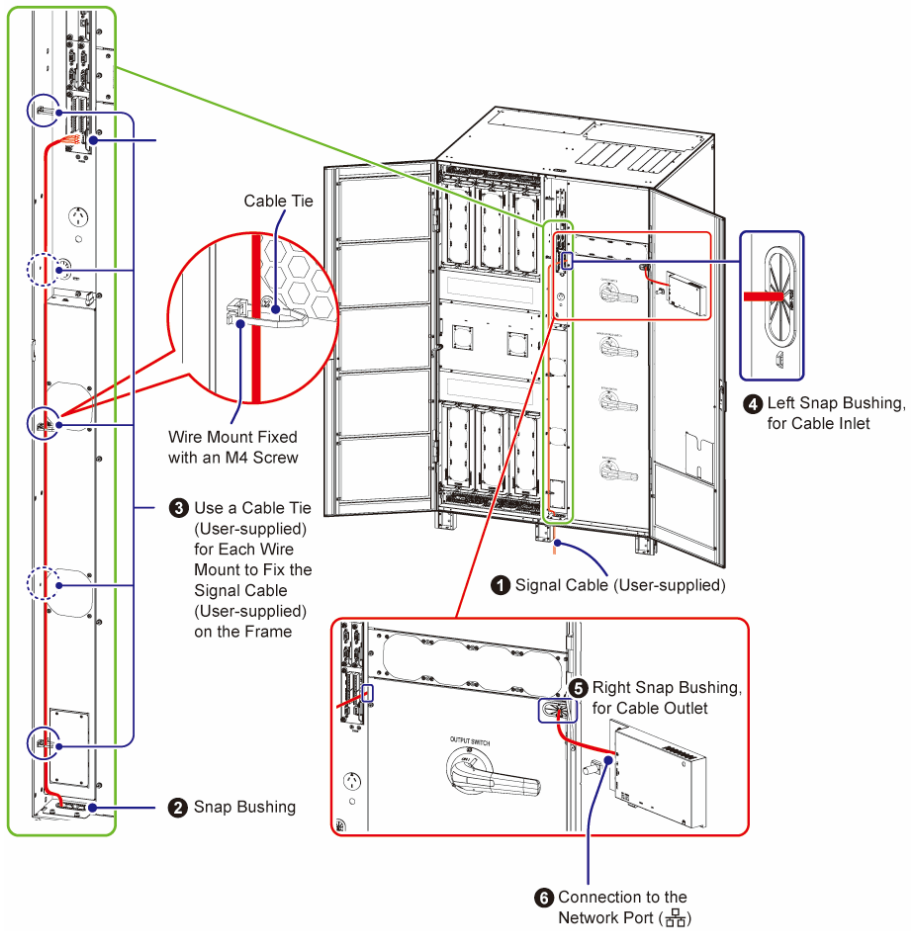

(Figure 4-23: 400/ 500/ 600kVA UPS_ Bottom Entry)

Chapter 5 : Installation and Wiring

5.1 Before Installation and Wiring

- Please read this user manual thoroughly before installation, wiring and operation. Only authorized Delta engineers or service personnel can perform installation, wiring, panel & cover removal, maintenance and operation. If you want to execute any action mentioned above by yourself, the action must be under the supervision of authorized Delta engineers or service personnel. If you use a forklift or other equipment to move the UPS, please make sure its load bearing is sufficient. Please refer to **Table 5-1**.
- The UPS must be connected to at least one external battery cabinet (user-supplied, handled and configured by Delta service personnel). Please refer to **5.5 External Battery Cabinet Connection Warnings** for relevant information.

5.2 Installation Environment

- Install the UPS indoors. Do not place it outdoors.
- Make sure that transportation routes (e.g. corridors, door gates, elevators, etc.) and installation area can accommodate and bear the weight of the UPS, external battery cabinet(s), and handling equipment. Please refer to **Table 5-1** for the floor weight loading information.

Table 5-1: UPS Floor Weight Loading Table

DPS Series UPS				
UPS Capacity	300kVA	400kVA	500kVA	600kVA
UPS Net Weight	515 kg (1135 lb)	700 kg (1543 lb)	811 kg (1788 lb)	970 kg (2138 lb)
Floor Weight Loading	954 kg/m ² (195.4 lb/ft ²)	648 kg/m ² (132.7 lb/ft ²)	751 kg/m ² (153.8 lb/ft ²)	898 kg/m ² (183.9 lb/ft ²)

- The 300kVA UPS **ONLY** allows cable routing from the top, while the 400/ 500/ 600 kVA UPS allows cable routing from the top or bottom. Please leave adequate space on the top or at the bottom of the UPS to allow cable entry.
- Ensure that the installation area is spacious enough for maintenance and ventilation. Install the external battery cabinet next to the UPS and for the UPS clearance, we suggest that you:
 1. Keep a distance of 100 cm (39.4") from the front of the UPS for maintenance and ventilation.
 2. Keep a distance of at least 30 cm (11.8") from the rear of the UPS for ventilation.
 3. Keep a distance of 60 cm (23.6") from the top of the UPS for maintenance and wiring.



NOTE:

Dust filters have been installed on the inner side of the UPS's front door(s) before shipment.

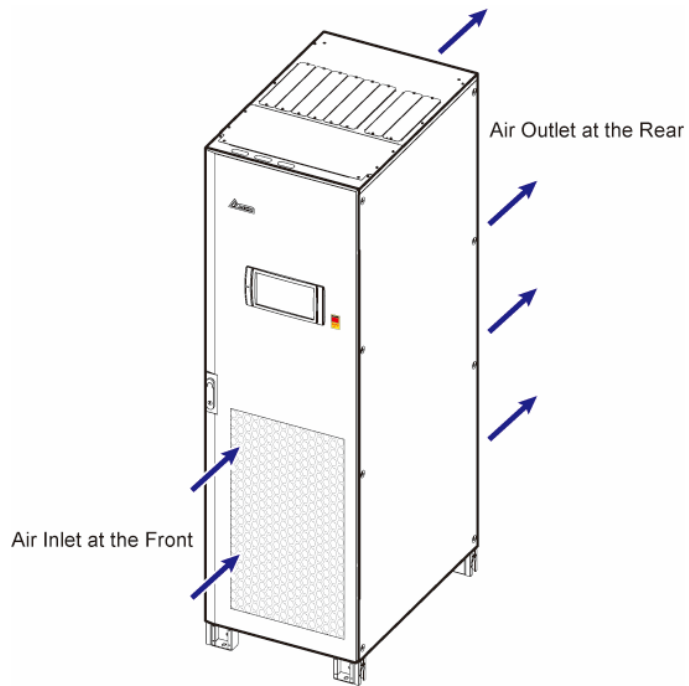

(Figure 5-1: 300kVA UPS_Air Inlet & Outlet Direction)

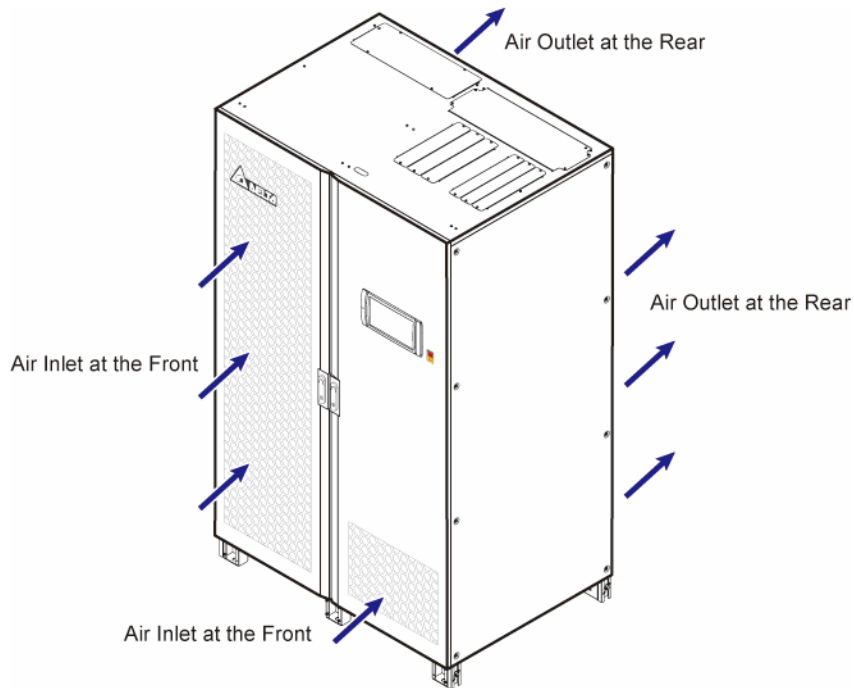

(Figure 5-2: 400/ 500/ 600kVA UPS_ Air Inlet & Outlet Direction)



WARNING:

1. Do not use air conditioners or similar equipment to blow into the rear of the UPS.
 2. Do not hinder ventilation of the UPS.
- Keep the installation area clean. Please note that wiring routes must be hermetic to prevent possible damage from rodents.
 - Keep the installation area's temperature around 25°C (77°F) and humidity within 95%. The highest operating altitude is 1000 meters (3280 ft) above sea level.
- For safety concerns, we suggest that you:
1. Equip surroundings of the installation area with CO₂ or dry powder fire extinguishers.
 2. Install the UPS in an environment where fireproof materials are used to construct the walls, floors and ceilings.
 3. Install the UPS on a floor that is made of noncombustible materials.
- Do not allow unauthorized personnel to enter the installation area and assign specified personnel to keep the UPS keys.

5.3 Fixing the UPS



NOTE:

Please use appropriate equipment (e.g. forklift) to move the UPS.

Please follow the steps below:

Step 1

Before fixing the UPS in a designated installation area, please double-check whether the area's floor weight loading is sufficient to bear the UPS, external battery cabinet(s) and handling equipment (e.g. forklift) to avoid accidents.

Step 2

Please firmly fix the stands which are at the bottom of the UPS on the ground to avoid UPS movement. Each stand requires an M12 expansion screw (provided by qualified service personnel).

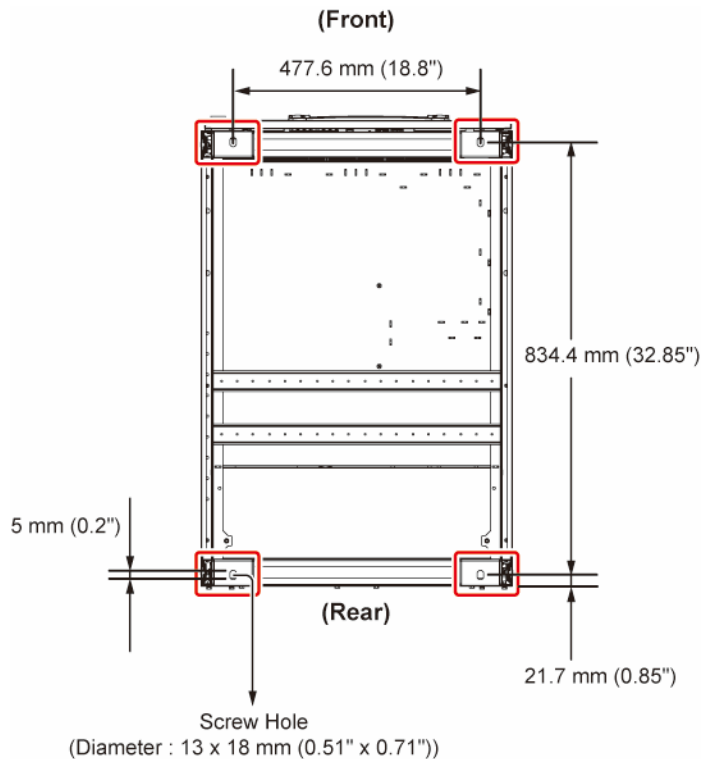

(Figure 5-3: 300kVA UPS_ Location of the Stands' Screw Holes)

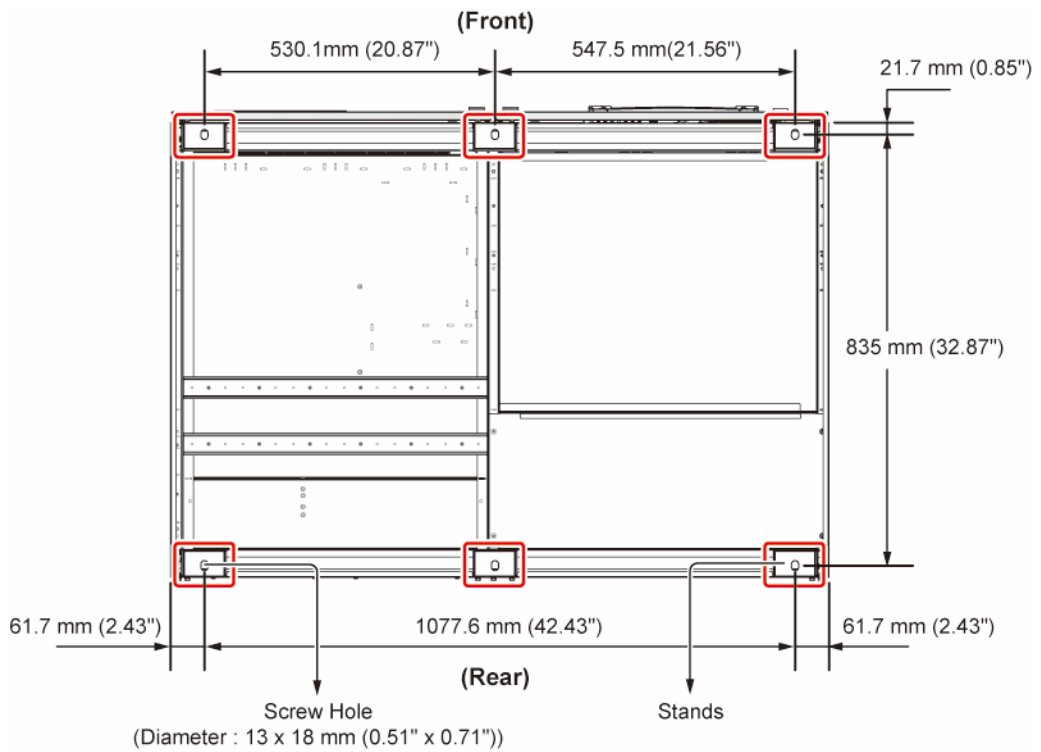

(Figure 5-4: 400/ 500/ 600kVA UPS_ Location of the Stands' Screw Holes)

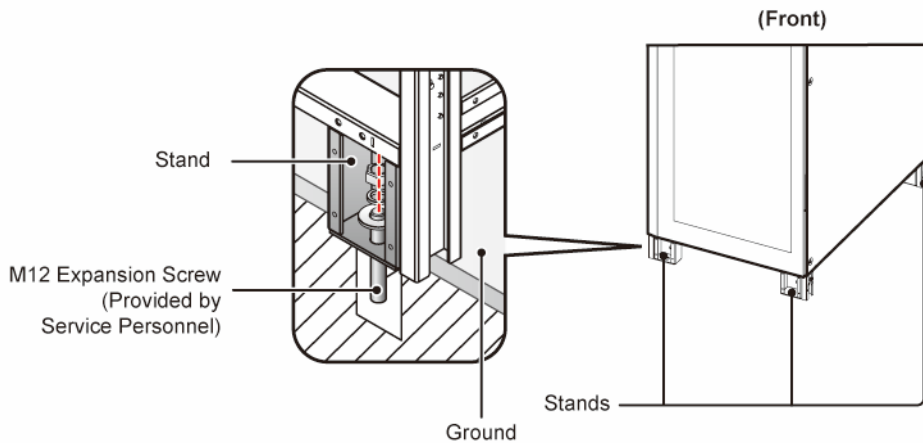

(Figure 5-5: 300kVA UPS_ Fix the Stands on the Ground)

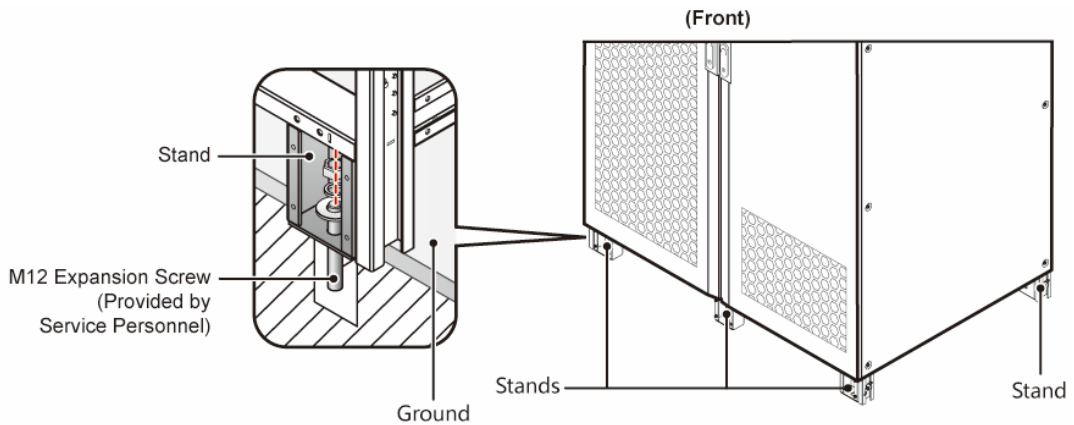

(Figure 5-6: 400/ 500/ 600kVA UPS_ Fix the Stands on the Ground)



WARNING:

If you don't fix the UPS stands on the ground, the UPS might topple over. For safety concerns, please fix the UPS stands on the ground firmly.

Step 3

Follow the instructions in **5.4 Wiring** to perform UPS wiring. When connecting the external battery cabinet(s), please refer to **5.5 External Battery Cabinet Connection Warnings** to perform external battery cabinet wiring. After wiring, please reinstall the switch panel(s) and then close the UPS front door(s).

Step 4

After the steps above have been completed, please refer to **5.6 Installation of Rodent Shields** to install the rodent shields.

5.4 Wiring

5.4.1 Pre-wiring Warnings



NOTE:

1. Before wiring, please ensure that you have followed **5.3 Fixing the UPS** to fix the UPS in the designated installation area firmly.
 2. Before wiring, please read **5.4 Wiring** thoroughly.
 3. Only authorized Delta engineers or service personnel can perform installation, wiring, panel & cover removal, maintenance and operation. If you want to execute any action mentioned above by yourself, the action must be under the supervision of authorized Delta engineers or service personnel.
- Before wiring or making any electrical connection, make sure that the power supplied to the input and output of the UPS is completely cut off.
 - Check if the size, diameter, phase and polarity are correct for each cable connecting to the UPS or external battery cabinet(s). Please refer to **Table 5-2**.



NOTE:

Table 5-2 is based on (1) default input/ output voltage: 220V, (2) default battery Q'ty: 40 PCS and (3) maximum charge current. For other conditions different from **Table 5-2**, please contact Delta service personnel for relevant values.

Table 5-2: Specifications of Input/ Output/ Battery Cables, Switches & Breakers

UPS Capacity		DPS 300kVA	DPS 400kVA	DPS 500kVA	DPS 600kVA
Input	Rated current at 220V with battery charging	500A	660A	820A	980A
	Recommended cable size (L1/ L2/ L3/ N)	120 mm ² × 2 PCS (250 kcmil × 2 PCS)	120 mm ² × 3 PCS (250 kcmil × 3 PCS)	150 mm ² × 3 PCS (300 kcmil × 3 PCS)	185 mm ² × 3 PCS (400 kcmil × 3 PCS)
	Maximum cable size (L1/ L2/ L3/ N)	185 mm ² × 2 PCS (400 kcmil × 2 PCS)	185 mm ² × 3 PCS (400 kcmil × 3 PCS)	240mm ² × 3 PCS (500 kcmil × 3 PCS)	300mm ² × 3 PCS (600 kcmil × 3 PCS)
	Cable lug width	30 mm (1.18")	30 mm (1.18")	34 mm (1.34")	38 mm (1.50")
	Maximum cable lug width	38 mm (1.50")	38 mm (1.50")	42 mm (1.65")	48 mm (1.89")
	Screw size	M12			

UPS Capacity		DPS 300kVA	DPS 400kVA	DPS 500kVA	DPS 600kVA
Output	Rated current at 220V	454A	606A	758A	909A
	Recommended cable size (L1/ L2/ L3/ N)	120 mm ² × 2 PCS (250 kcmil × 2 PCS)	120 mm ² × 3 PCS (250 kcmil × 3 PCS)	150 mm ² × 3 PCS (300 kcmil × 3 PCS)	185 mm ² × 3 PCS (400 kcmil × 3 PCS)
	Maximum cable size (L1/ L2/ L3/ N)	185 mm ² × 2 PCS (400 kcmil × 2 PCS)	185 mm ² × 3 PCS (400 kcmil × 3 PCS)	240 mm ² × 3 PCS (500 kcmil × 3 PCS)	300 mm ² × 3 PCS (600 kcmil × 3 PCS)
	Cable lug width	30 mm (1.18")	30 mm (1.18")	34 mm (1.34")	38 mm (1.50")
	Maximum cable lug width	38 mm (1.50")	38 mm (1.50")	42 mm (1.65")	48 mm (1.89")
	Screw size	M12			
Battery	Nominal discharge current (Condition: 2V per cell)	658A	877A	1096A	1315A
	Maximum discharge current (Condition: 1.75V per cell)	752A	1003A	1253A	1504A
	Recommended cable size (+/- N)	185 mm ² × 2 PCS (400 kcmil × 2 PCS)	150 mm ² × 3 PCS (300 kcmil × 3 PCS)	150 mm ² × 4 PCS (300 kcmil × 4 PCS)	240 mm ² × 4 PCS (500 kcmil × 4 PCS)
	Maximum cable size (+/- N)	300 mm ² × 2 PCS (600 kcmil × 2 PCS)	240 mm ² × 3 PCS (500 kcmil × 3 PCS)	240 mm ² × 4 PCS (500 kcmil × 4 PCS)	300 mm ² × 4 PCS (600 kcmil × 4 PCS)
	Cable lug width	38 mm (1.50")	34 mm (1.34")	34 mm (1.34")	42 mm (1.65")
	Maximum cable lug width	48 mm (1.89")	42 mm (1.65")	42 mm (1.65")	48 mm (1.89")
	Screw size	M12			
Tightening Torque	M12 = 500 ± 10kgf-cm (434 ± 8.7lb-in)				

UPS Capacity	DPS 300kVA	DPS 400kVA	DPS 500kVA	DPS 600kVA
Input Switch (Q1)	630A	800A	1000A	1250A
Bypass Switch (Q2)	630A	800A	1000A	1250A
Manual Bypass Switch (Q3)	630A	800A	1000A	1250A
Output Switch (Q4)	630A	800A	1000A	1250A
External Battery Cabinet's Switch (Q5)	1000A	1250A	1400A	1700A



NOTE:

1. In accordance with National Electrical Codes (NEC), please install a suitable conduit and bushing for cable protection.
 2. Please refer to national and local electrical codes for acceptable non-fuse switches, breakers and cable sizes.
 3. The cables mentioned in **Table 5-2** with PVC material and with temperature resistance up to 105°C (221°F) are suggested.
- If there is a floating voltage between the input power's neutral line (N) and ground line (⊕), and you require that the VNG of the UPS should be zero, we suggest that you install an isolation transformer in front of the input side of the UPS, and connect the isolation transformer's secondary neutral (N) to the grounding terminal (⊕) at the proximal end of the isolation transformer.
 - The (main/ bypass) AC source must be a three-phase four-wire system (Y configuration) and meets the specifications specified on the UPS rating label. Make sure the connection is in the positive phase sequence.
 - Check the battery polarity when connecting the external battery cabinet(s) to the UPS. Do not connect the battery polarity in reverse. For relevant information, please refer to **5.5 External Battery Cabinet Connection Warnings**.
 - Connect the external battery cabinet's grounding terminal (⊕) to the UPS's grounding terminal (⊕).
 - The UPS's grounding terminal (⊕) must be grounded. Please use ring-type terminals when wiring.



WARNING:

1. Wrong wiring will cause damage to the UPS and electric shock.
2. The UPS will not work normally if the neutral (N) of the power source (main/ bypass/ battery) is not properly connected to the UPS Output terminal (N).
3. If the UPS is not grounded, the power boards and components might be damaged after the UPS is powered on.

5.4.2 Single Input to Dual Input Modification



NOTE:

Please keep the removed components properly for future use. If you want to modify the UPS from dual input into single input, please use the removed screws and nuts to connect the cables/ bus bars back to the AC Input terminals (L1/ L2/ L3) and the Bypass Input terminals (L1/ L2/ L3).

● 300kVA UPS Single Input to Dual Input Modification

Step 1

Open the front door and remove the switch panels, and you will see the AC Input terminals and the Bypass Input terminals.

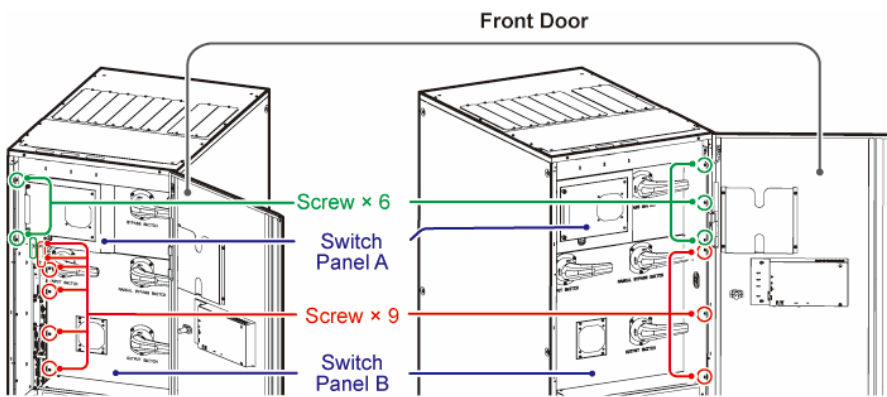

(Figure 5-7: 300kVA UPS_ Locations of Switch Panels and Screws)

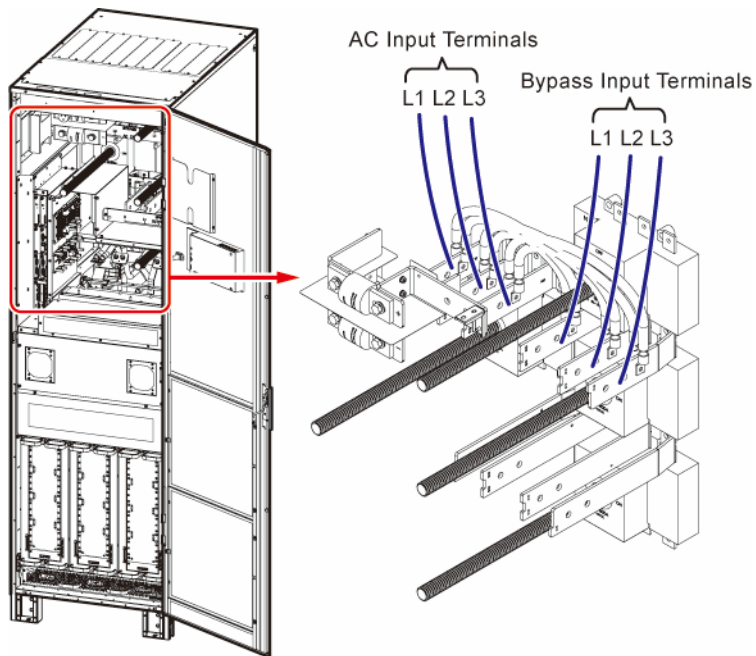

(Figure 5-8: 300kVA UPS_ AC Input Terminals & Bypass Input Terminals)

Step 2

Remove all the cables between the AC Input terminals (L1/ L2/ L3) and the Bypass Input terminals (L1/ L2/ L3).

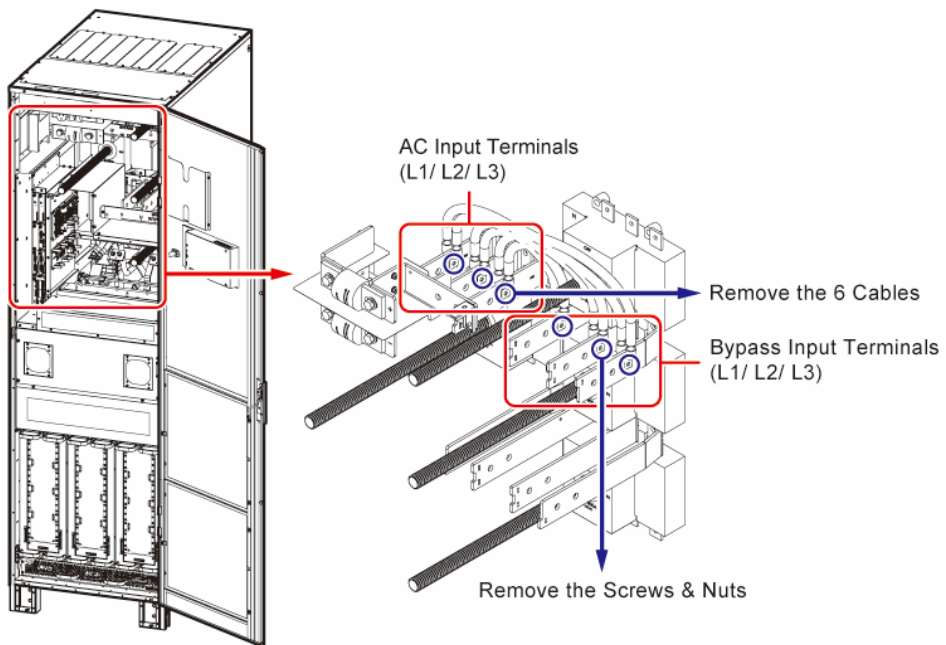

(Figure 5-9: 300kVA UPS_ Remove the Cables between the AC Input Terminals & Bypass Input Terminals)

● **400/ 500/ 600kVA UPS Single Input to Dual Input Modification**

Step 1

Open the front door and remove the switch panel, and you will see the AC Input terminals and the Bypass Input terminals.

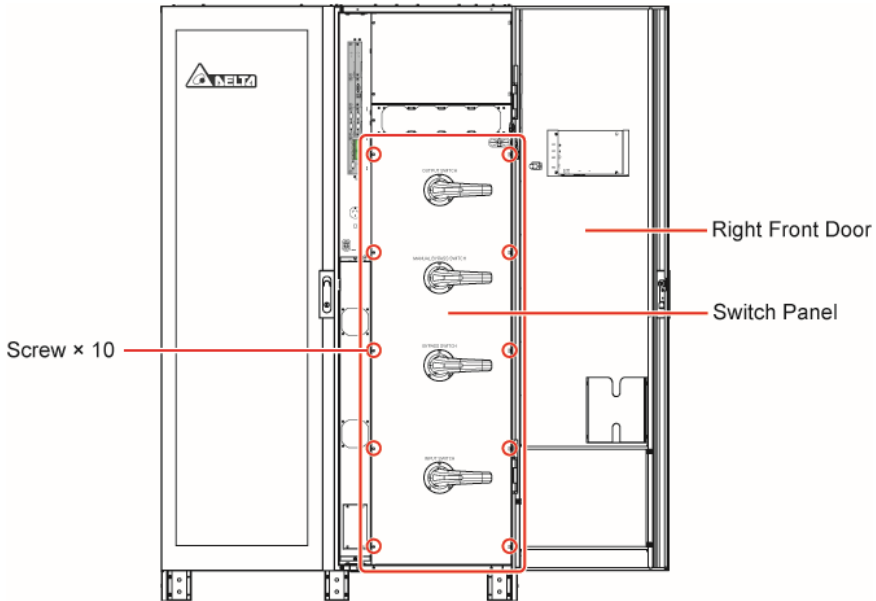

(Figure 5-10: 400/ 500/ 600kVA UPS_ Locations of the Switch Panel and Screws)

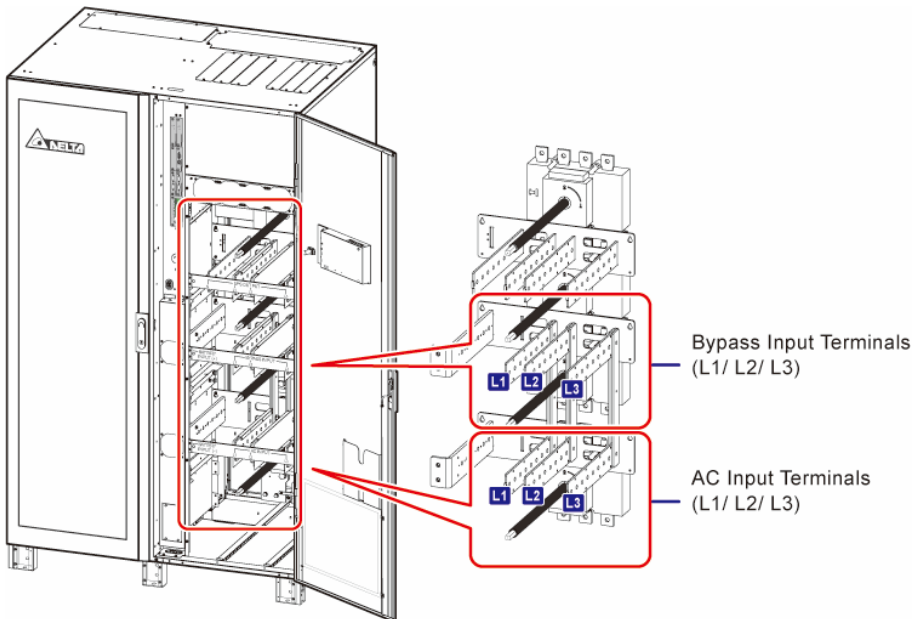

(Figure 5-11: 400/ 500/ 600kVA UPS_ AC Input Terminals & Bypass Input Terminals)

Step 2

Remove the six bus bars between the AC Input terminals (L1/ L2/ L3) and the Bypass Input terminals (L1/ L2/ L3).

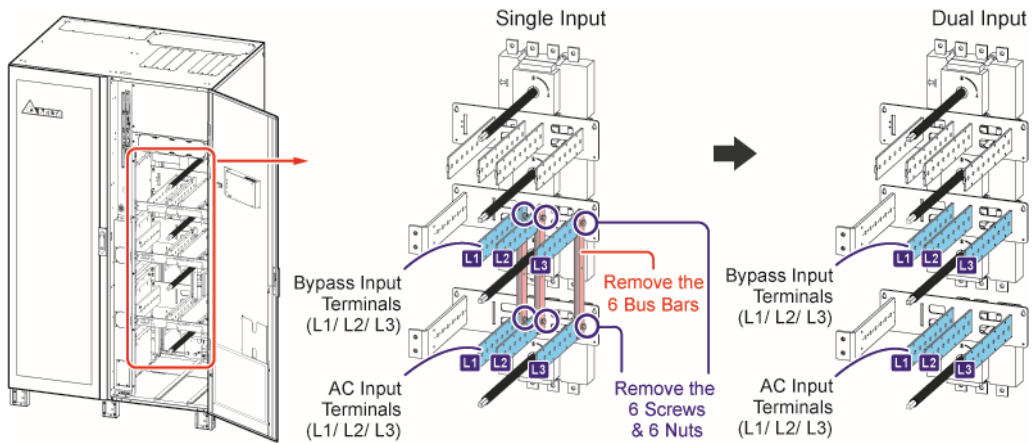

(Figure 5-12: 400/ 500/ 600kVA UPS_ Remove the Bus Bars between the AC Input Terminals & Bypass Input Terminals)

5.4.3 Installation of Insulating Plates for Top & Bottom Wiring



NOTE:

Installation of insulating plates is not needed for the 300kVA UPS.

The factory default installation of the insulating plates is for top wiring. If you adopt bottom wiring, follow the steps below to change the installation of the insulating plates.

Step 1

Open the right front door and remove the switch panel (refer to **Figure 5-10**). There are a total of nine insulating plates.

(Applicable to Top Wiring)

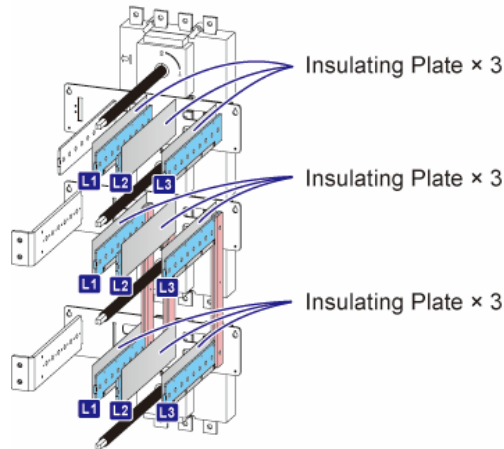

(Figure 5-13: Insulating Plates Position_ Applicable to Top Wiring (Factory Default))

Step 2

Remove the four plastic rivets on each of the insulating plates. Turn the insulating plates 180° and install them back to the original positions.



NOTE:

1. If the plastic rivets are damaged, please use spares in the accessory package for replacement.
2. Make sure that each insulating plate has been installed in accordance with the steps mentioned above.

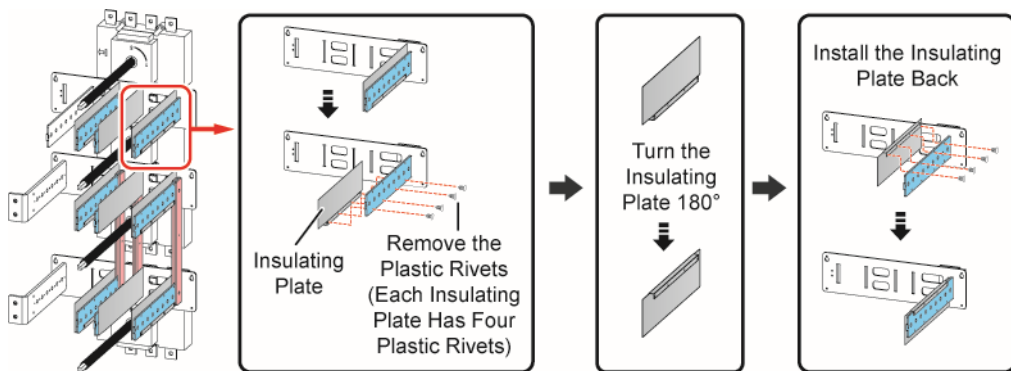

(Figure 5-14: Change the installation of the Insulating Plates for Bottom Wiring)

After all the steps above are completed, the installation of insulating plates for bottom wiring is as below.

(Applicable to Bottom Wiring)

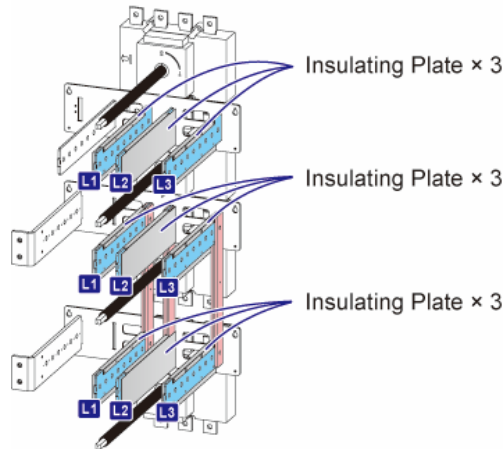

(Figure 5-15: Insulating Plates Position_ Applicable to Bottom Wiring)

5.4.4 Single Unit Wiring



NOTE:

Before wiring, please read **5.4 Wiring** thoroughly and make sure relevant conditions have been met.

Refer to **Table 5-3** for information of the wiring terminals. For the wiring diagrams and instructions, please refer to the following sections.

Table 5-3: Wiring Terminals & Wiring Information

No.	Item	Description	Function
1	AC Input Terminals	L1/ L2/ L3 terminals	Connect to the main AC source; it is required to connect wire N of the main AC source to the UPS Output terminal (N).
2	Bypass Input Terminals	L1/ L2/ L3 terminals	Single input: There is no need to connect the Bypass Input terminals. Dual input: Connect to the bypass AC source and connect wire N of the bypass AC source to the UPS Output terminal (N).
3	UPS Output Terminals	L1/ L2/ L3/ N terminals	Connect to the critical loads.
4	Battery Input Terminals	+/- terminals	Connect to the external battery cabinet(s); it is required to connect wire N of the external battery cabinet(s) to the UPS Output terminal (N).

No.	Item	Description	Function
5	⊕	One grounding terminal	For the UPS's protective earthing.
6	⊕	Two grounding terminals	Connect to the external battery cabinet's grounding (⊕) and the critical load's grounding (⊕).

5.4.4.1 300kVA UPS Single Input (Single Unit)

When there is only one AC power source, single unit wiring procedures are as follows.

Step 1

The 300kVA UPS only allows cable routing from the top. Please leave adequate space above the UPS.

Step 2

Open the front door and remove the switch panels, and you will see the wiring terminals inside.

Step 3

Please remove the top covers to allow cable entry from the top.

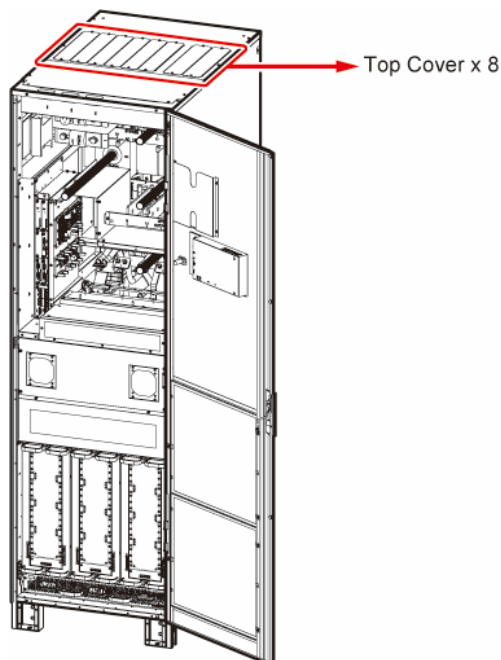

(Figure 5-16: Location of the 300kVA UPS's Top Covers)

Step 4

Make sure that the Input Switch (Q1), Bypass Switch (Q2), Manual Bypass Switch (Q3), and Output Switch (Q4) are in the **OFF** position.

Step 5

Make sure each external battery cabinet's breaker (Q5) is in the **OFF** position.

Step 6

Follow **Table 5-2** to select proper input, output, and battery cables.

Step 7

Connect the cables of the main AC source, output and external battery cabinet(s) to the UPS. Please refer to **Table 5-3**, **5.5 External Battery Cabinet Connection Warnings**, and the following diagrams to perform wiring.

Single Input_ Top Wiring_ Step 1

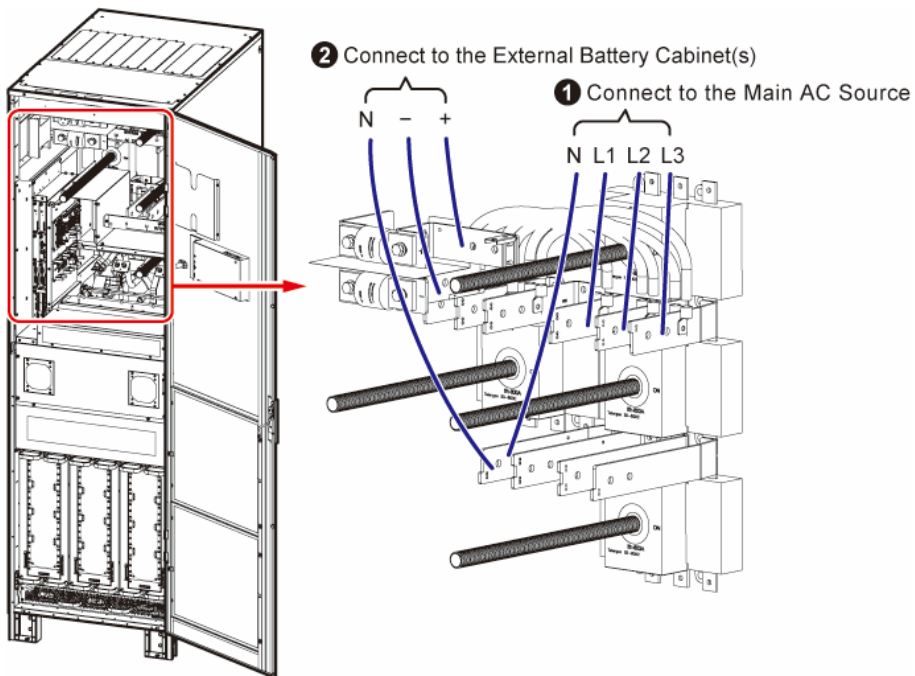

(Figure 5-17: 300kVA UPS Single Unit Single Input_ Top Wiring_ Step 1)

Single Input_ Top Wiring_ Step 2

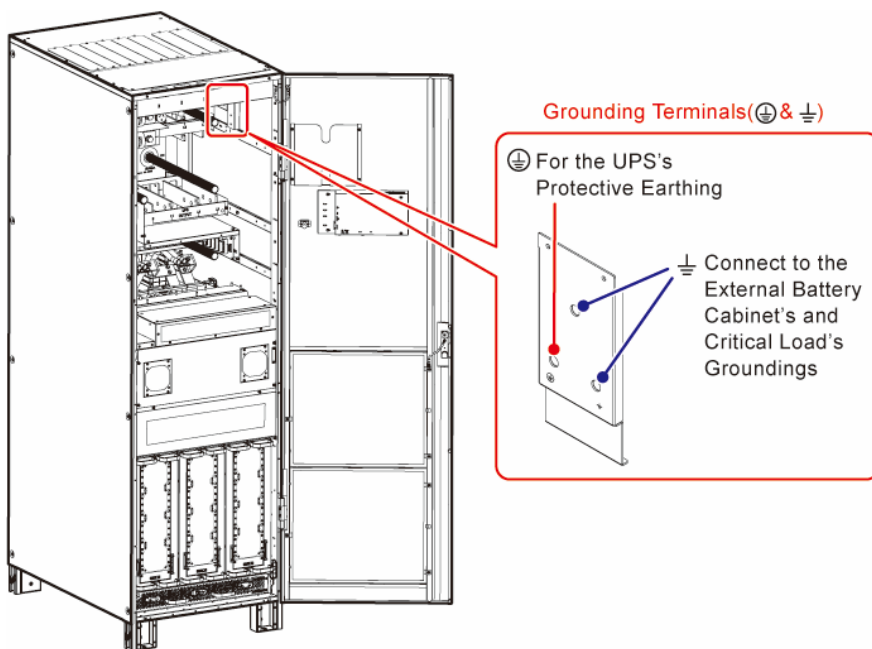

(Figure 5-18: 300kVA UPS Single Unit Single Input_ Top Wiring_ Step 2)

Single Input_ Top Wiring_ Step 3

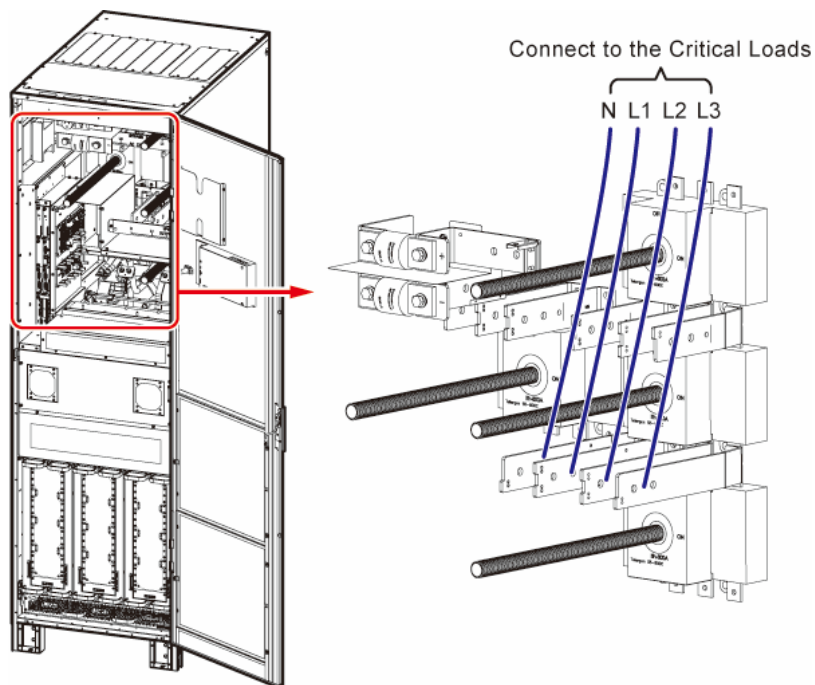

(Figure 5-19: Single Unit Single Input_ Top Wiring_ Step 3)

Step 8

Follow the figure below to ground the UPS, external battery cabinet(s) and connected critical loads.

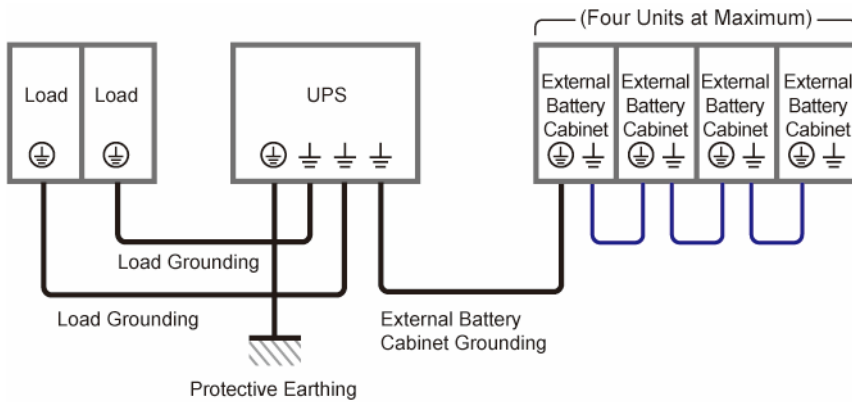

(Figure 5-20: Grounding Diagram_ Single Unit)

5.4.4.2 300kVA UPS Dual Input (Single Unit)

When there are two AC power sources, single unit wiring procedures are as follows.

Step 1

Follow **5.4.2 Single Input/ Dual Input Modification** to modify the UPS from single input to dual input.

Step 2

Follow **Step 1 ~ Step 6** in **5.4.4.1 300kVA UPS Single Input (Single Unit)**.

Step 3

Connect the cables of the main AC source, bypass source, output and external battery cabinet(s) to the UPS. Please refer to **Table 5-3, 5.5 External Battery Cabinet Connection Warnings** and the following diagrams to perform wiring.

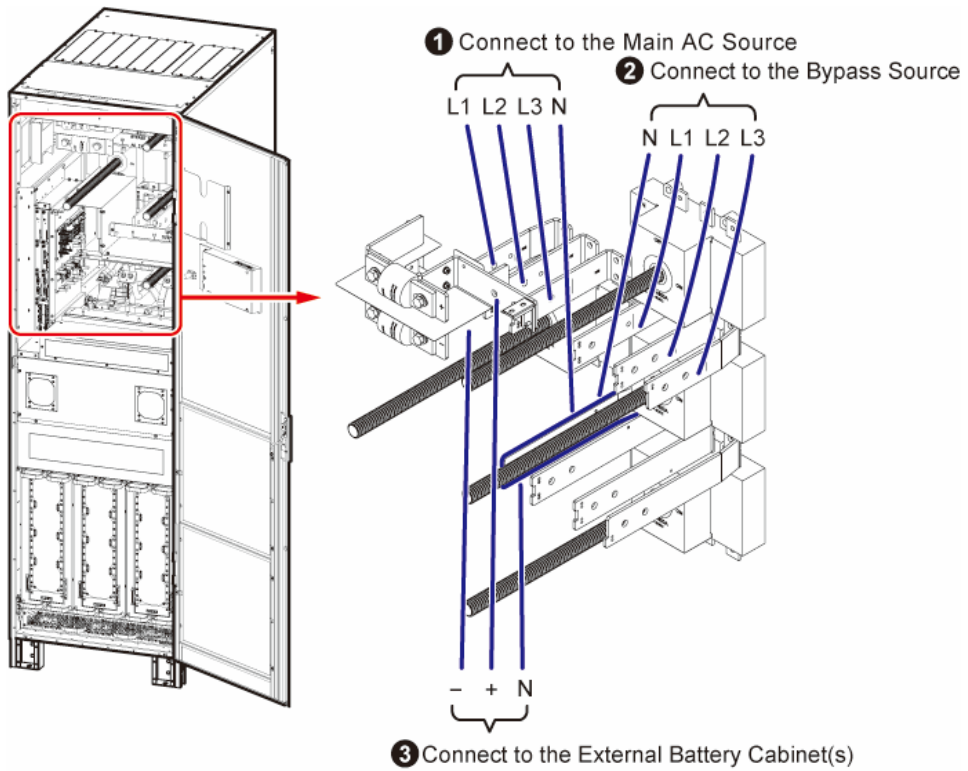

(Figure 5-21: Single Unit Dual Input_ Top Wiring_ Step 1)

Dual Input_ Top Wiring_ Step 2

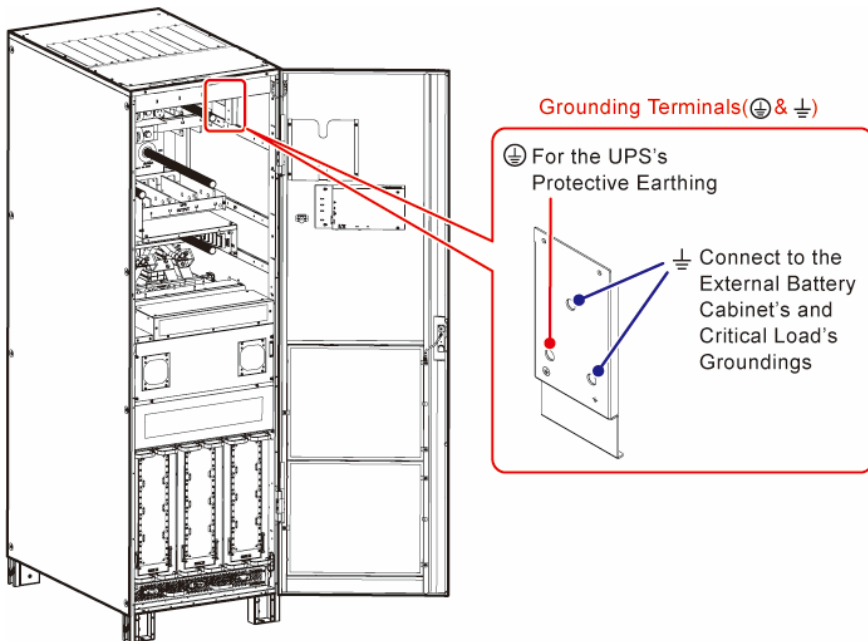

(Figure 5-22: Single Unit Dual Input_ Top Wiring_ Step 2)

Dual Input_ Top Wiring_ Step 3

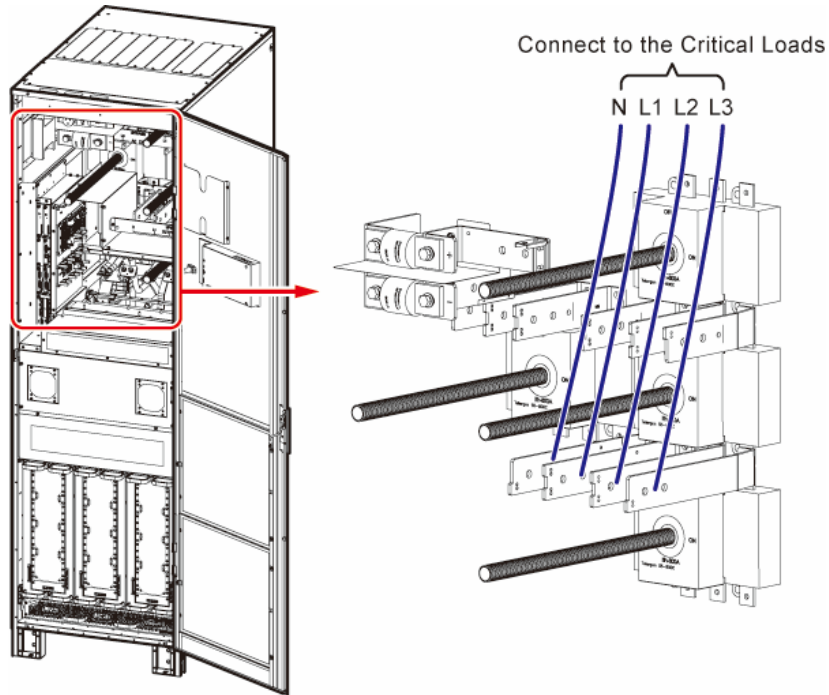

(Figure 5-23: Single Unit Dual Input_ Top Wiring_ Step 3)

Step 4

Follow **Figure 5-20** to ground the UPS, external battery cabinet(s) and connected critical loads.

5.4.4.3 400/ 500/ 600kVA UPS Single Input (Single Unit)

When there is only one AC power source, single unit wiring procedures are as follows.

Step 1

The 400/ 500/ 600kVA UPS allows cable routing from the top or bottom. Please leave adequate space above or below the UPS.

Step 2

Open the right front door and remove the switch panel, and you will see the wiring terminals inside.

Step 3

For top wiring, please remove the top covers.

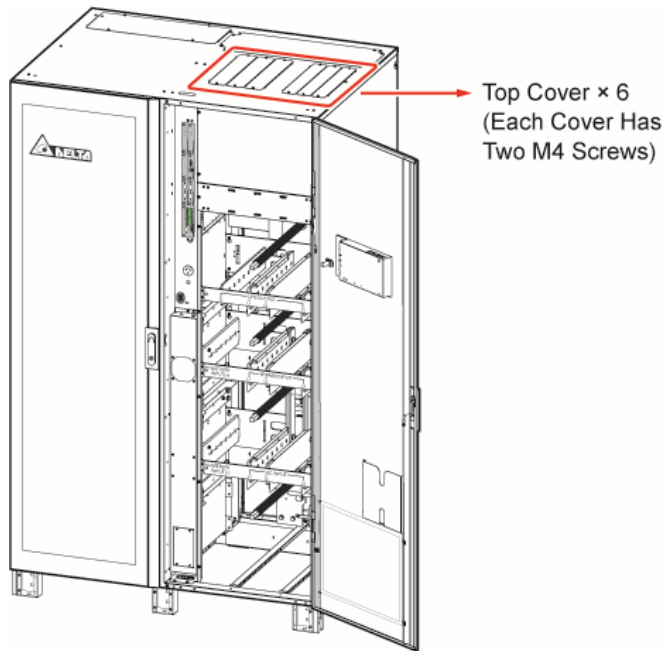

Top Cover × 6
(Each Cover Has
Two M4 Screws)

(Figure 5-24: Location of the 400/ 500/ 600kVA UPS's Top Covers)

Step 4

For bottom wiring, please remove the bottom cover.

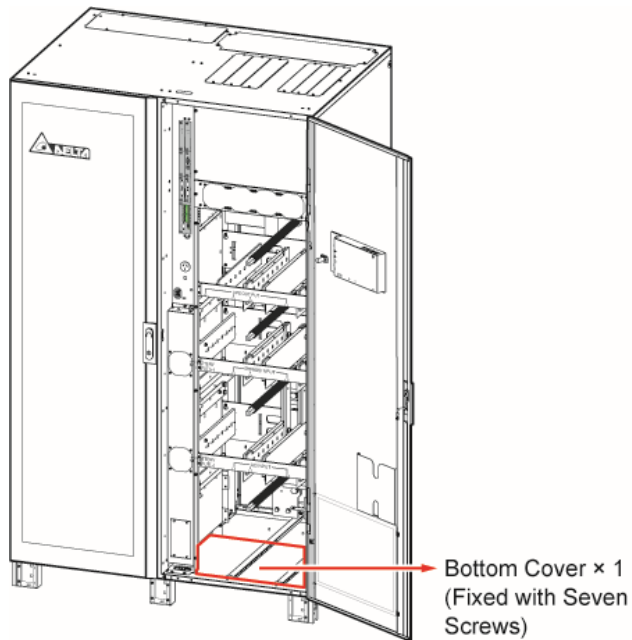

Bottom Cover × 1
(Fixed with Seven
Screws)

(Figure 5-25: Location of the 400/ 500/ 600kVA UPS's Bottom Cover)

Step 5

Make sure that the Input Switch (Q1), Bypass Switch (Q2), Manual Bypass Switch (Q3), and Output Switch (Q4) are in the **OFF** position.

Step 6

Make sure each external battery cabinet's breaker (Q5) is in the **OFF** position.

Step 7

Follow **Table 5-2** to select proper input, output, and battery cables.

Step 8

Connect the cables of the main AC source, output and external battery cabinet(s) to the UPS. Please refer to **Table 5-3, 5.5 External Battery Cabinet Connection Warnings** and the following diagrams to perform wiring.

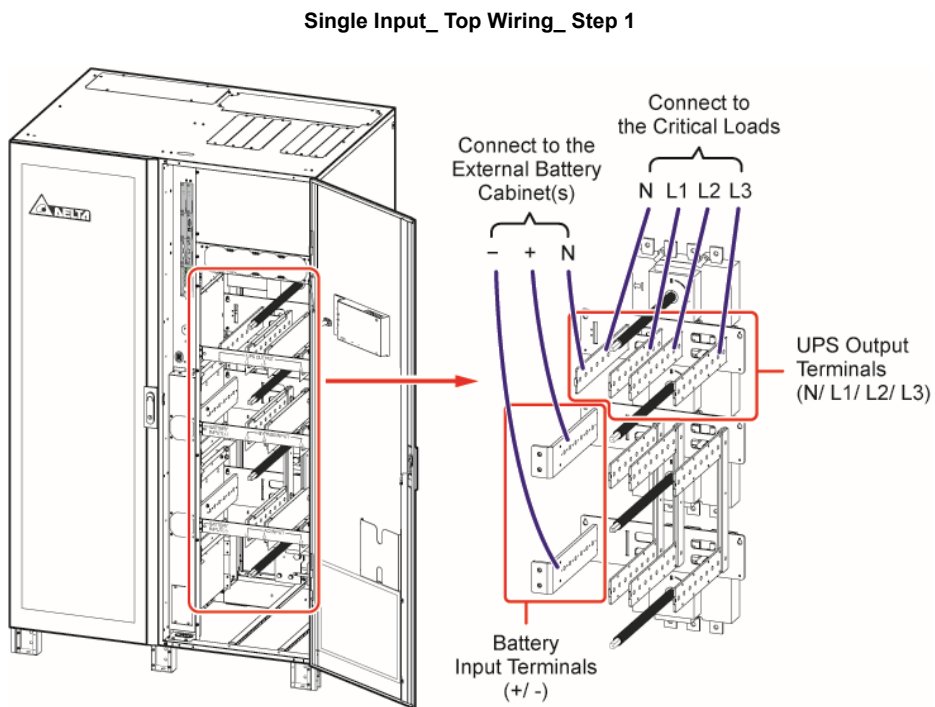

(Figure 5-26: 400/ 500/ 600kVA UPS Single Unit Single Input_ Top Wiring_ Step 1)

Single Input_Top Wiring_ Step 2

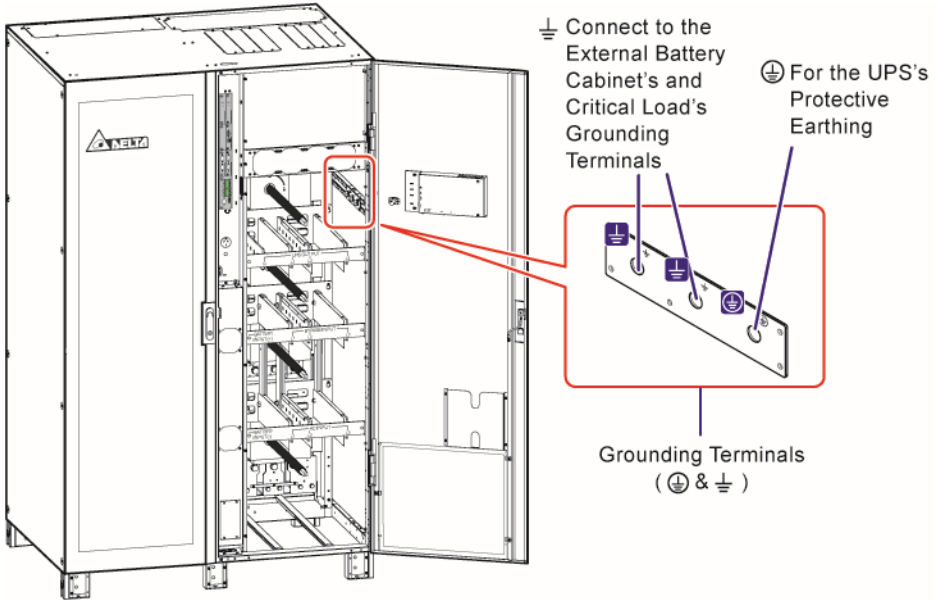

(Figure 5-27: 400/ 500/ 600kVA UPS Single Unit Single Input_Top Wiring_ Step 2)

Single Input_Top Wiring_ Step 3

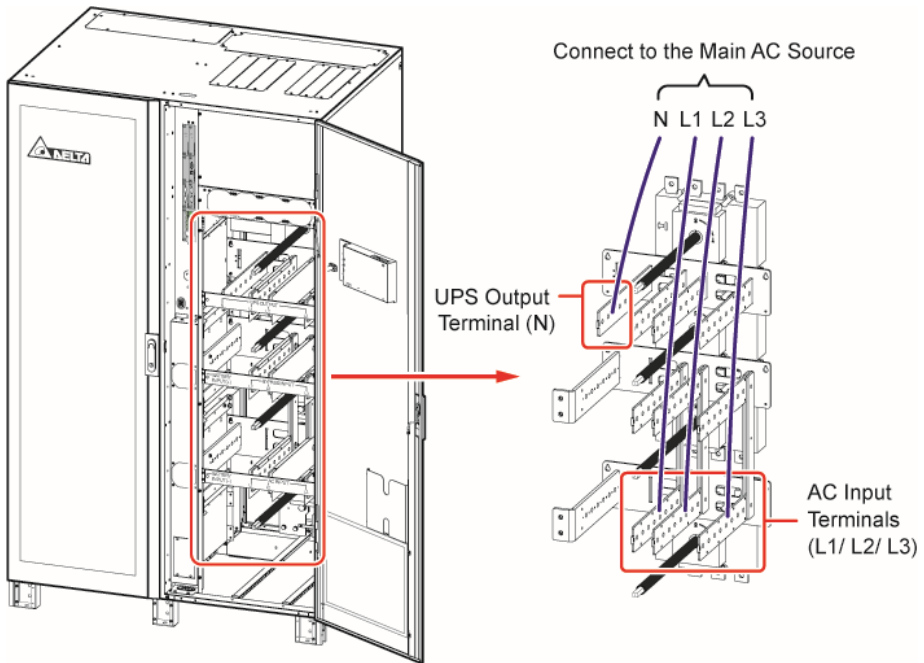

(Figure 5-28: 400/ 500/ 600kVA UPS Single Unit Single Input_Top Wiring_ Step 3)

Single Input_ Bottom Wiring_ Step 1

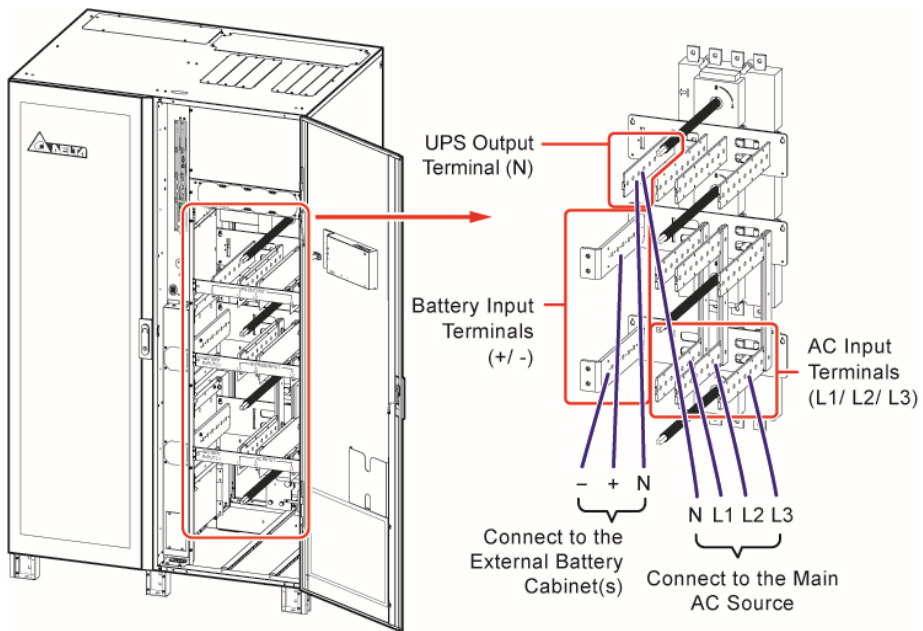

(Figure 5-29: 400/ 500/ 600kVA UPS Single Unit Single Input_ Bottom Wiring _ Step 1)

Single Input_ Bottom Wiring_ Step 2

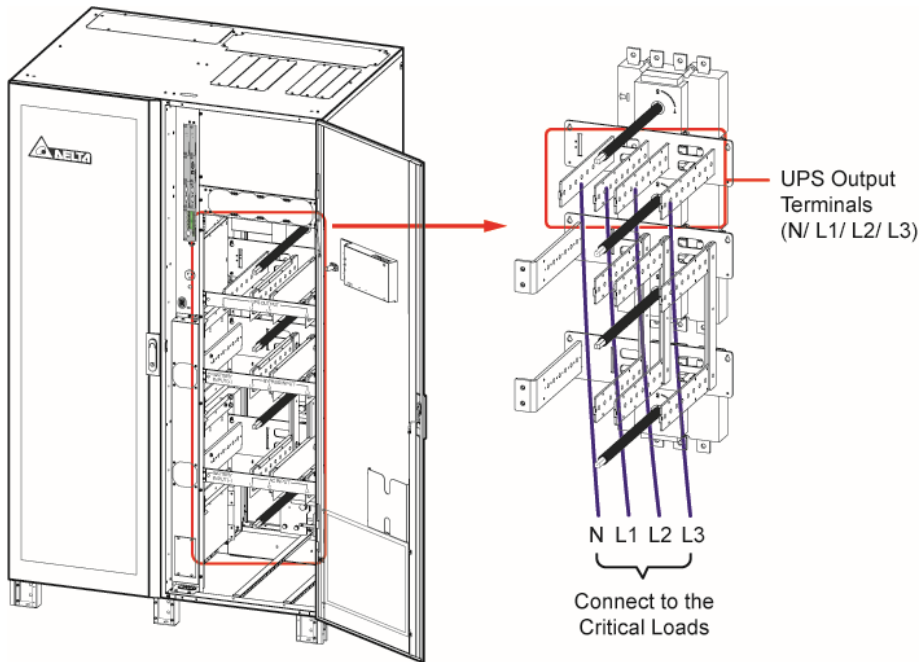

(Figure 5-30: 400/ 500/ 600kVA UPS Single Unit Single Input_ Bottom Wiring _ Step 2)

Single Input_ Bottom Wiring_ Step 3

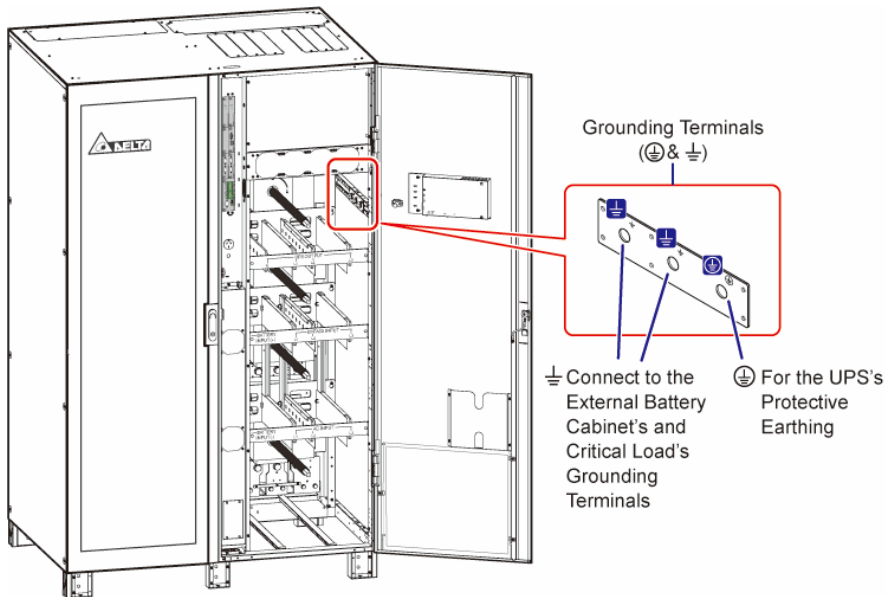

(Figure 5-31: 400/ 500/ 600kVA UPS Single Unit Single Input_ Bottom Wiring_ Step 3)

Step 9

Follow **Figure 5-20** to ground the UPS, external battery cabinet(s) and connected critical loads.

5.4.4.4 400/ 500/ 600kVA UPS Dual Input (Single Unit)

When there are two AC power sources, single unit wiring procedures are as follows.

Step 1

Follow **5.4.2 Single Input/ Dual Input Modification** to modify the UPS from single input to dual input.

Step 2

Follow **Step 1 ~ Step 7** in **5.4.4.3 400/ 500/ 600kVA UPS Single Input (Single Unit)**.

Step 3

Connect the cables of the main AC source, bypass source, output and external battery cabinet(s) to the UPS. Please refer to **Table 5-3, 5.5 External Battery Cabinet Connection Warnings** and the following diagrams to perform wiring.

Dual Input_Top Wiring_Step 1

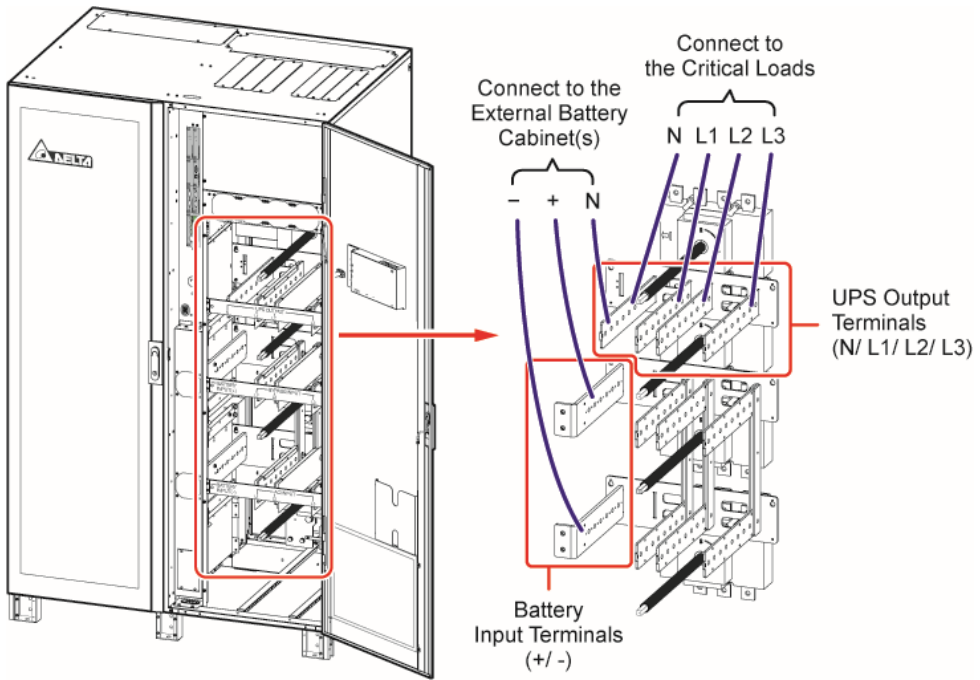

(Figure 5-32: 400/ 500/ 600kVA UPS Single Unit Dual Input_Top Wiring_ Step 1)

Dual Input_Top Wiring_Step 2

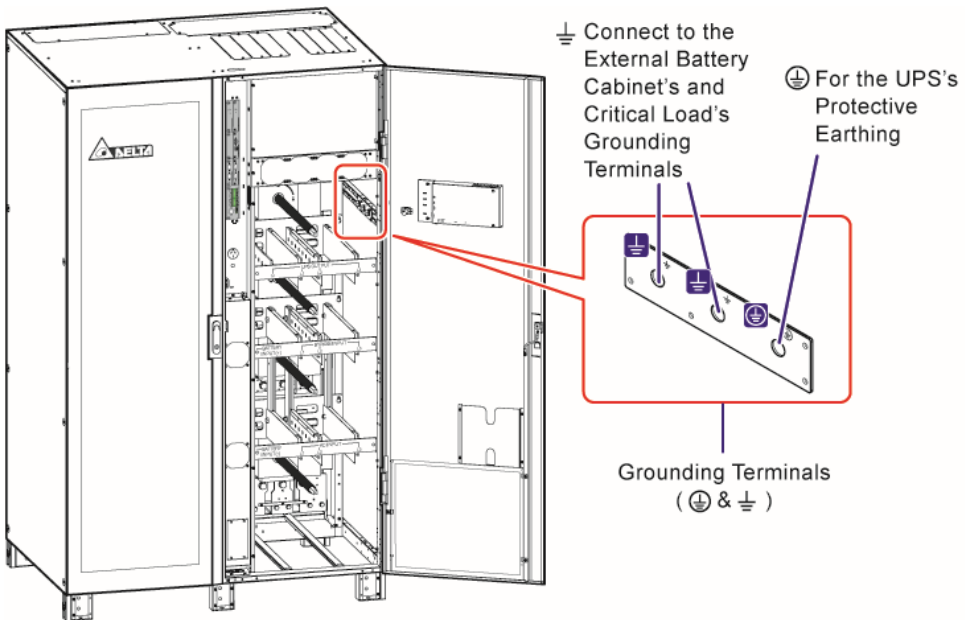

(Figure 5-33: 400/ 500/ 600kVA UPS Single Unit Dual Input_Top Wiring _ Step 2)

Dual Input_ Top Wiring_ Step 3

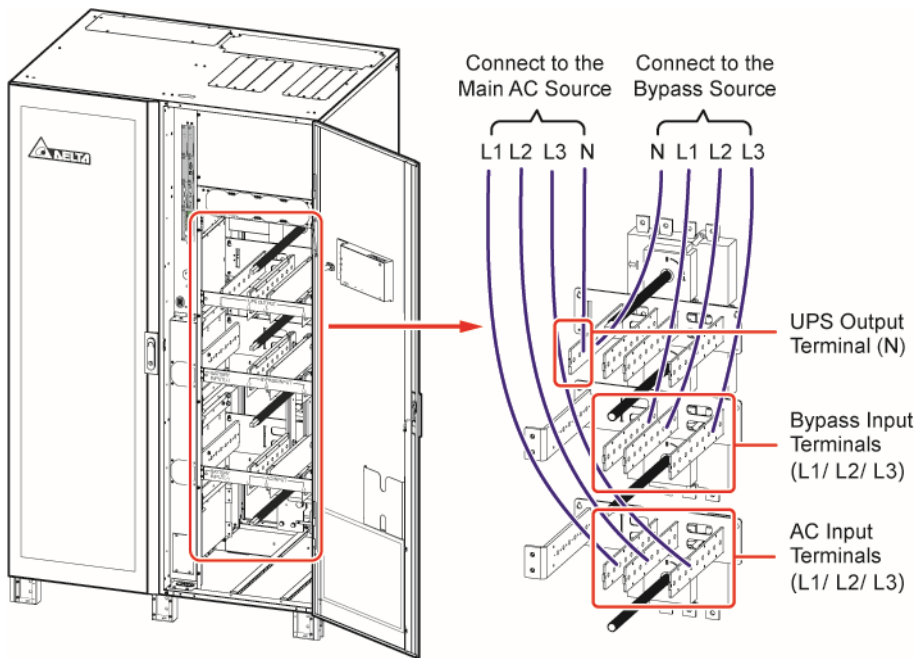

(Figure 5-34: 400/ 500/ 600kVA UPS Single Unit Dual Input_ Top Wiring _ Step 3)

Dual Input_ Bottom Wiring_ Step 1

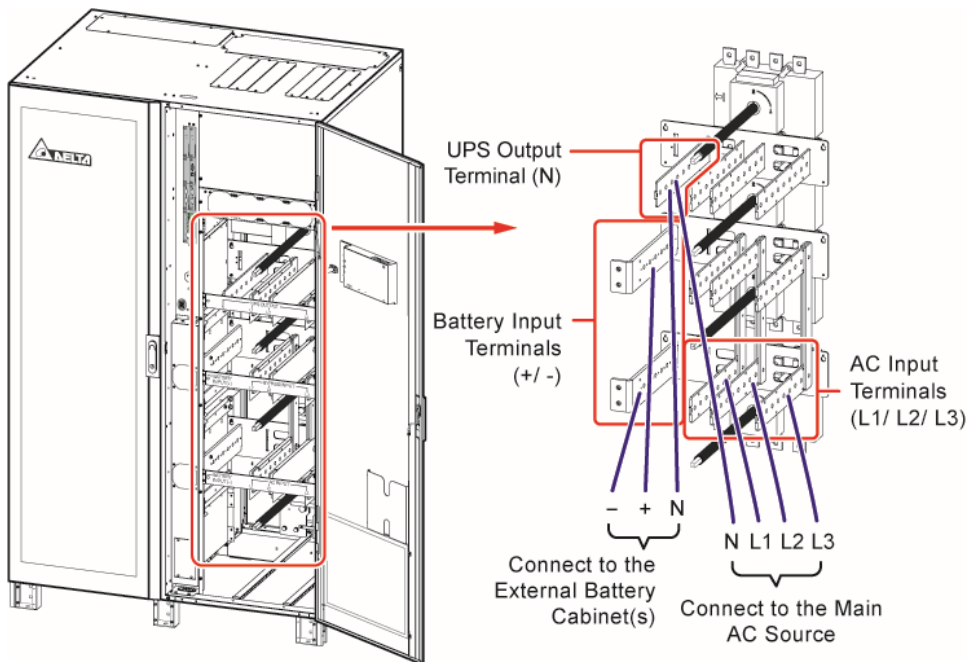

(Figure 5-35: 400/ 500/ 600kVA UPS Single Unit Dual Input_ Bottom Wiring_ Step 1)

Dual Input_ Bottom Wiring_ Step 2

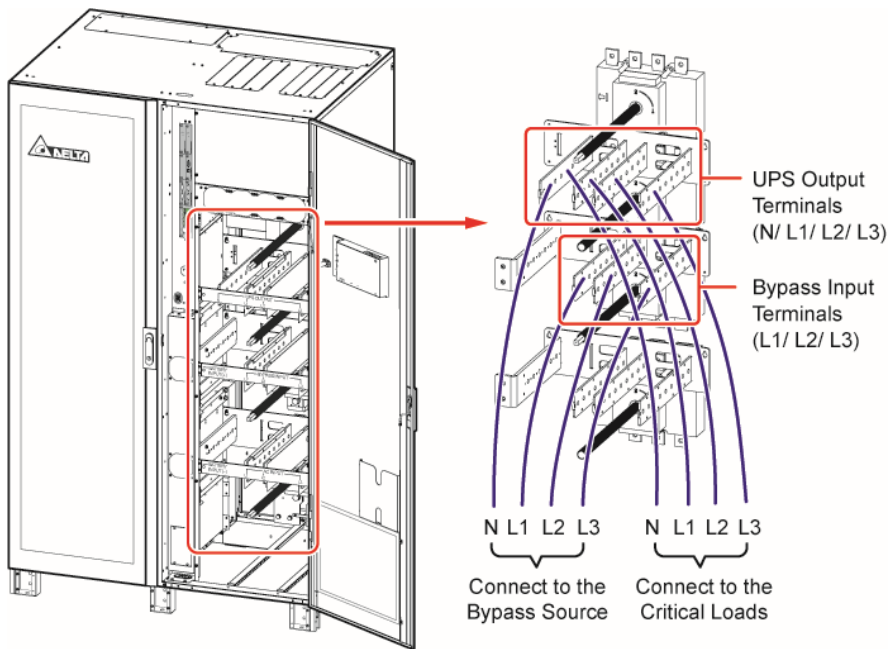

(Figure 5-36: 400/ 500/ 600kVA UPS Single Unit Dual Input_ Bottom Wiring_ Step 2)

Dual Input_ Bottom Wiring_ Step 3

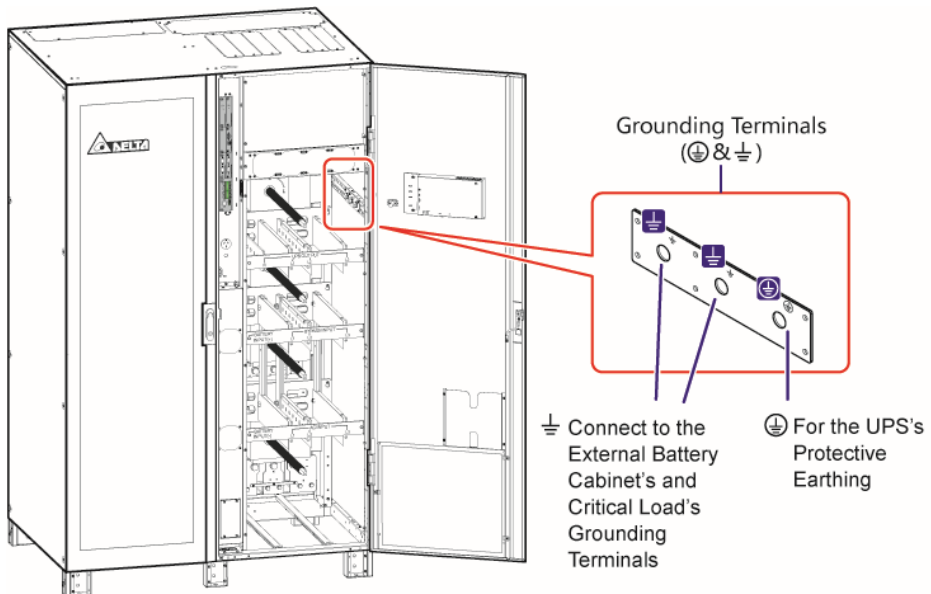

(Figure 5-37: 400/ 500/ 600kVA UPS Single Unit Dual Input_ Bottom Wiring_ Step 3)

Step 4

Follow **Figure 5-20** to ground the UPS, external battery cabinet(s) and connected critical loads.

5.4.5 Parallel Units Wiring



NOTE:

1. Up to eight UPS units can be paralleled for redundancy and capacity expansion. Only the UPSs with the same capacity, voltage, frequency and version can be paralleled. Please only use the provided parallel cable to parallel the UPS units. Otherwise, parallel functions will fail.
2. When the UPSs are paralleled, the length of each unit's bypass input cables plus output cables must be the same. This ensures that the parallel UPSs can equally share the critical loads in Bypass mode.
3. Before wiring, please read **5.4 Wiring** thoroughly and make sure relevant conditions have been met.

The single input parallel wiring procedures is taken as an example.

Step 1

For 300kVA UPS, please follow **Step 1 ~ Step 6** in **5.4.4.1 300kVA UPS Single Input (Single Unit)**.

For 400/ 500/ 600kVA UPS, please follow **Step 1 ~ Step 7** in **5.4.4.3 400/ 500/ 600kVA UPS Single Input (Single Unit)**.

Step 2

Connect the cables of the main AC source, output and external battery cabinet(s) to the UPS. Please refer to **Table 5-3, Figure 5-38** and **5.5 External Battery Cabinet Connection Warnings**.

For the wiring diagrams of the 300kVA UPS, refer to **Figure 5-17 ~ Figure 5-19**.

For the wiring diagrams of the 400/ 500/ 600kVA UPS, refer to **Figure 5-26 ~ Figure 5-31**.

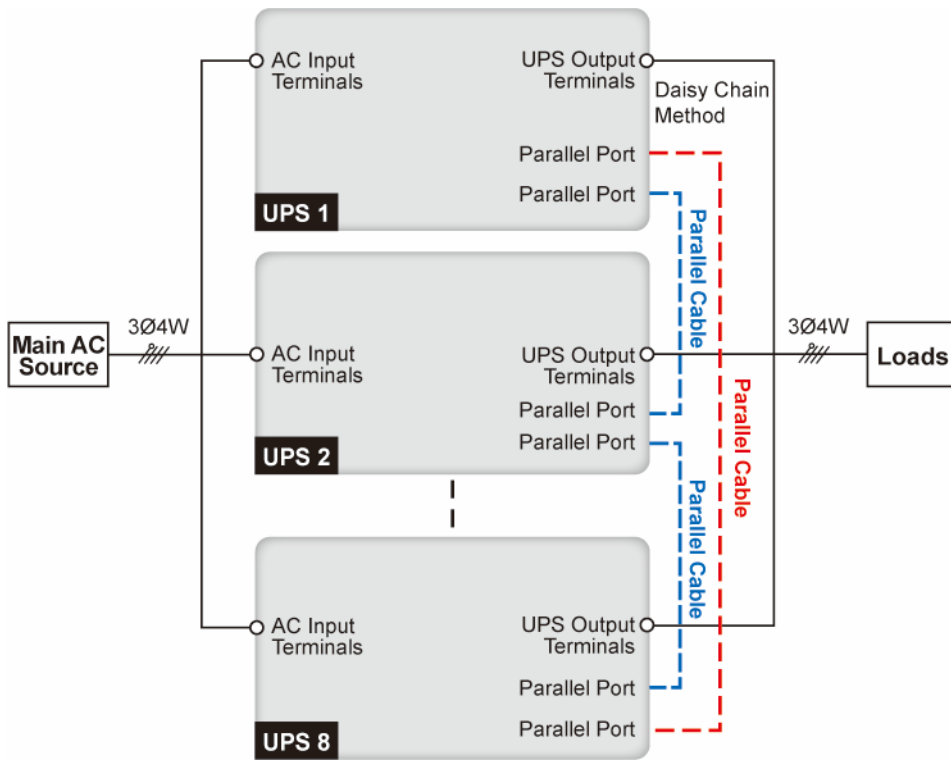

(Figure 5-38: Parallel Units Single Input Wiring Diagram)

Step 3

Use the provided parallel cables*1 to connect the parallel ports of the parallel units. Please adopt Daisy Chain method. For the parallel port location, refer to **Figure 4-1**.



NOTE:

*1 One parallel cable is provided in each UPS's accessory package.

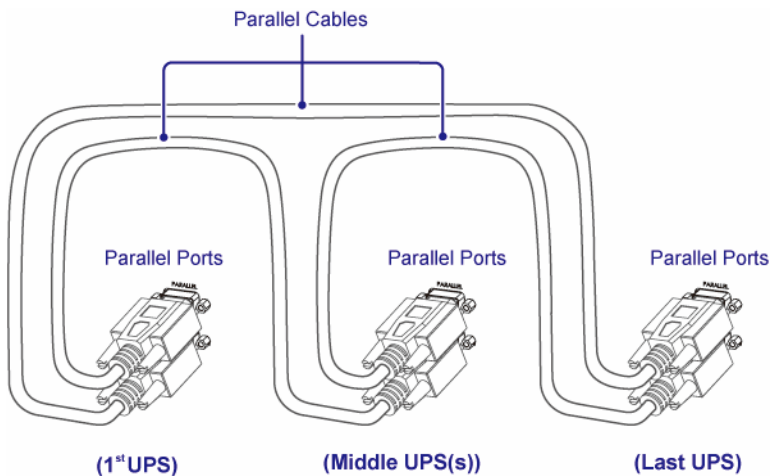

(Figure 5-39: Parallel Port Connection_ Daisy Chain Method)

Follow the instructions below to route the provided parallel cables.



NOTE:

1. In accordance with National Electrical Codes (NEC), please install a suitable conduit and bushing for cable protection.
2. If you adopt top entry, please remove the knockout cover(s) at the top of the UPS before performing the steps below.

● **300kVA UPS_ Parallel Cable Routing Method (Top Entry Only)**

(Step A)

Install the snap bushing(s). There are three cable entrances that you can choose to use. The snap bushings are provided in the accessory package.

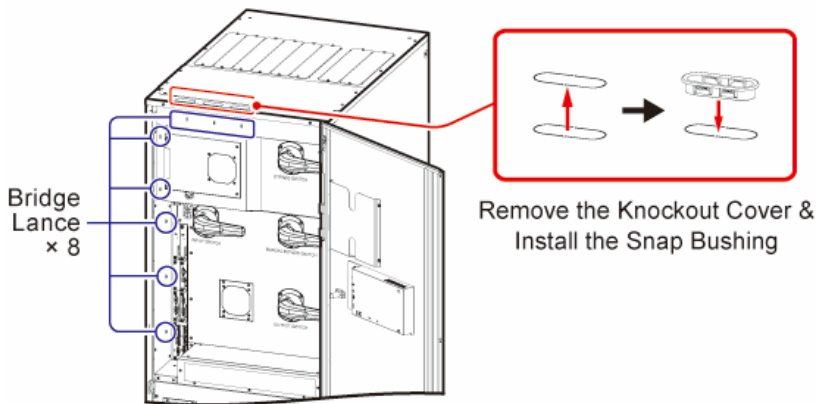

(Figure 5-40: 300kVA UPS_ Parallel Cable Routing-1)

(Step B)

Refer to instructions ❶ ~ ❹ below to properly route and secure the parallel cables with cable ties (user-supplied). There are eight bridge lances that you can choose to use.

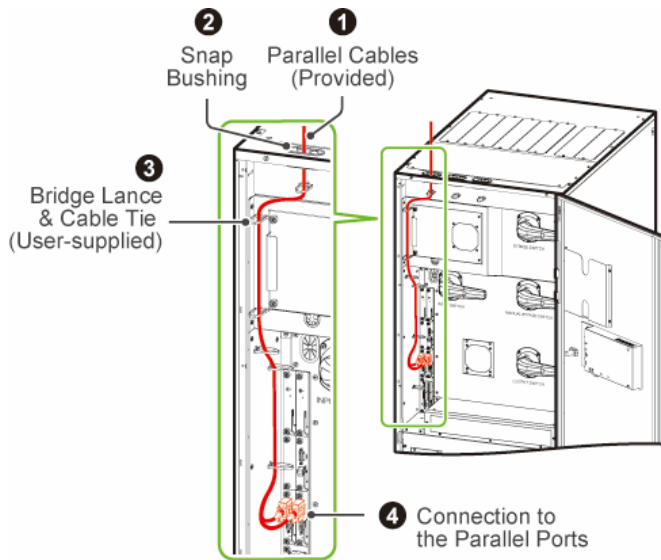

(Figure 5-41: 300kVA UPS_ Parallel Cable Routing-2)

- **400/ 500/ 600kVA UPS_ Parallel Cable Routing Method (Top & Bottom Entry)**

(Step A)

For top entry, use the snap bushing, wire mounts and M4 screws in the accessory package to install the snap bushing and fasten the wire mounts on the frame.

For bottom entry, use the wire mounts and M4 screws in the accessory package to install the wire mounts on the frame.

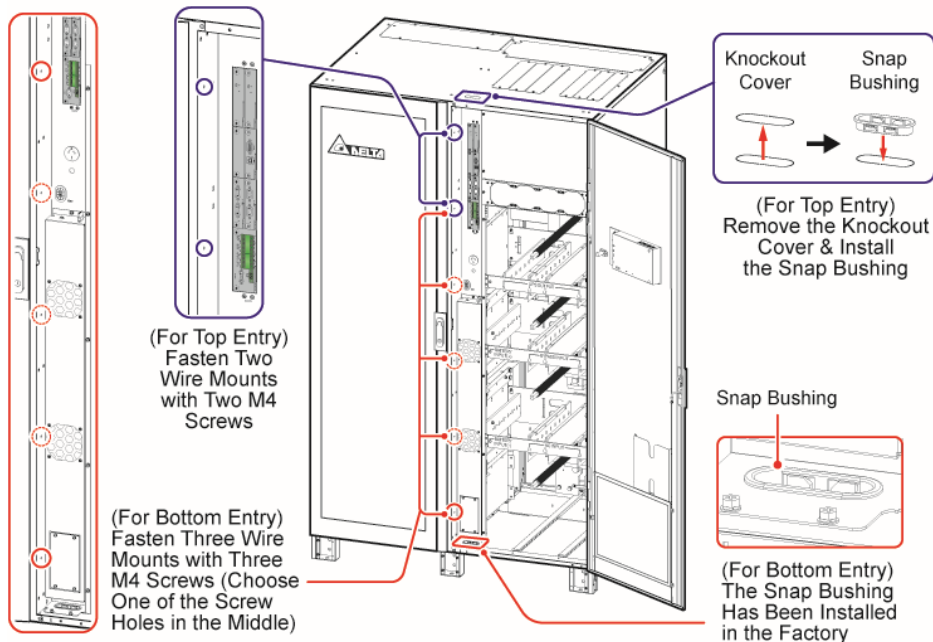

(Figure 5-42: 400/ 500/ 600kVA UPS_ Parallel Cable Routing-1)

(Step B)

For top/ bottom entry, route the provided parallel cables (1) through the snap bushing (2), use a cable tie (user-supplied) for each wire mount to fix the parallel cables on the frame (3), and connect the parallel cables to the parallel ports (4).



NOTE:

The number of the wire mounts and cable ties shown in the figures are for reference only. The actual number depends on your on-site application.

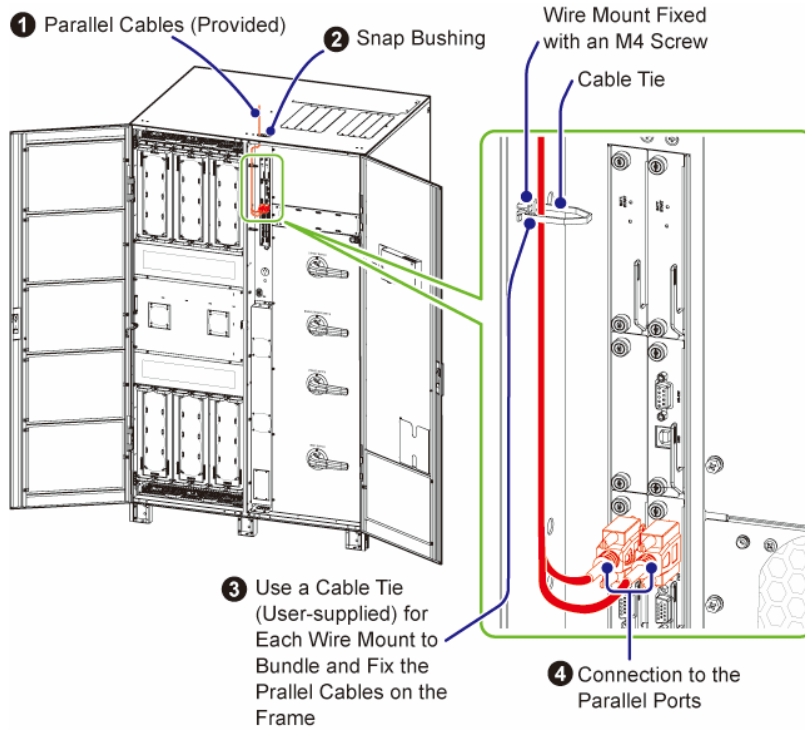

(Figure 5-43: 400/ 500/ 600kVA UPS_ Parallel Cable Routing -2_ Top Entry)

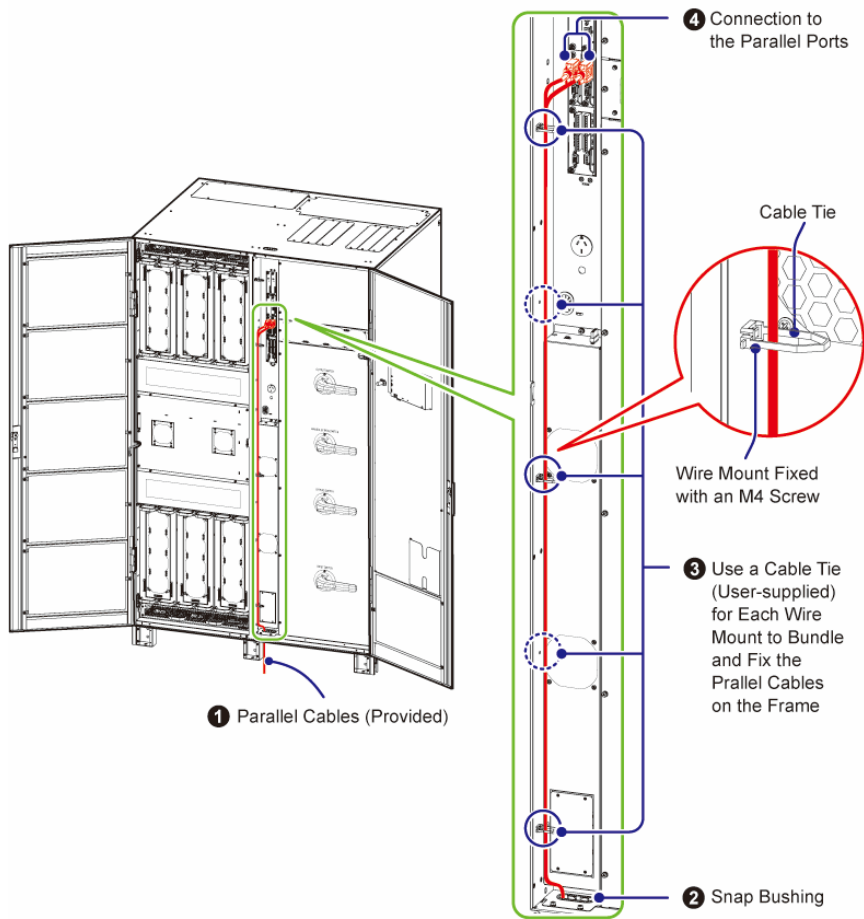

(Figure 5-44: 400/ 500/ 600kVA UPS_ Parallel Cable Routing-2_ Bottom Entry)

Step 4

Follow the figure below to ground the parallel UPS units, external battery cabinet(s) and connected critical loads.

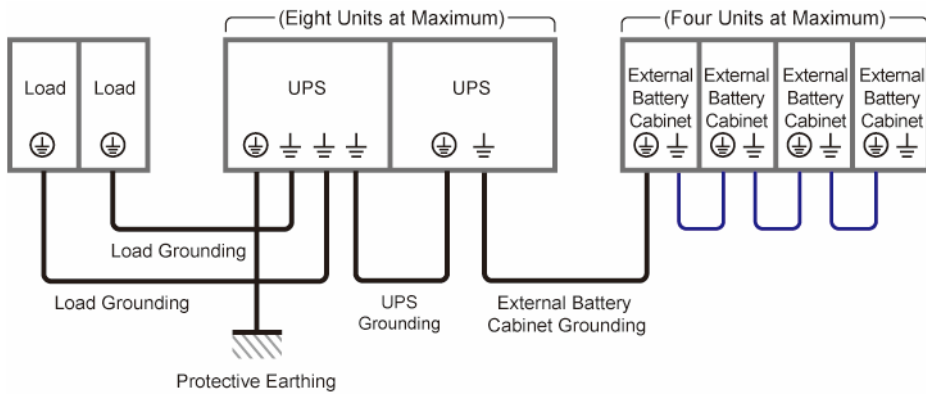

(Figure 5-45: Grounding Diagram_ Parallel Units)



WARNING:

Before start-up of the parallel units, qualified service personnel must set each UPS's '**Parallel Group ID**' (1 or 2) and '**Parallel ID**' (1 ~ 8) through the LCD. Otherwise, the parallel UPSs cannot be started. Please refer to **7.6.5 Parallel Setting**.

5.5 External Battery Cabinet Connection Warnings



NOTE:

The information of the battery parameters in this chapter may not be applicable to the lithium-ion batteries. For relevant information, please refer to the manual of the lithium-ion batteries. Whether you use the lead-acid batteries or the lithium-ion batteries, please contact Delta service personnel for any battery/ battery cabinet's setup and configurations.

You should connect the UPS with at least one external battery cabinet to ensure that the connected critical loads are protected when a power failure occurs. You can connect up to four units of external battery cabinets to the UPS.

- To ensure that the batteries are fully charged, please charge for at least 8 hours before the initial use of the UPS. This guarantees that the UPS can provide sufficient backup power to the critical loads when a power failure occurs. The charging procedures are as follows.
 - (1) Connect the main AC source and the external battery cabinet(s) to the UPS. Please refer to **5.4 Wiring**.
 - (2) Follow **6. UPS Operation** to turn on the UPS and the external battery cabinet(s). After that, the unit will automatically charge the batteries.
- To connect the external battery cabinet(s) to the UPS, please refer to **5.4 Wiring** and **Figure 5-47**.
- For the external battery cabinet's grounding information, please refer to **Figure 5-20** and **Figure 5-45**.
- **Battery Parameters**

No.	UPS Rating	300kVA	400kVA	500kVA	600kVA
	Item	Description			
1	Charge Voltage	Float charge voltage: $\pm 272\text{Vdc}$ (default)			
		Equalized charge voltage: $\pm 280\text{Vdc}$ (default)			
2	Charge Current	Default: $\pm 10\text{A}$			
		$\pm 90\text{A}$ (Max.)	$\pm 120\text{A}$ (Max.)	$\pm 150\text{A}$ (Max.)	$\pm 180\text{A}$ (Max.)
3	Low Battery Shutdown Voltage	$\pm 210\text{Vdc}$ (default)			
4	Battery Quantity	12V \times 40 PCS (default)			

- The charge current is adjustable from 10A to the maximum. Each adjustment level is 1A.

- According to on-site requirements, you can choose 12V × 30/ 32/ 34/ 36/ 38/ 40/ 42/ 44 or 46 PCS of batteries. Change of the battery quantity will influence the applied specifications. For battery selection, installation and replacement, please contact your local dealer or customer service.
- You must set up the number of battery strings on the LCD according to the on-site installation. otherwise, the batteries will be over-charged, not fully charged or even seriously damaged.
- Only use the same type of batteries from the same supplier. Never use old, new and different Ah batteries at the same time.
- The number of batteries must meet the UPS requirements.
- Do not connect the batteries in reverse.
- Use a voltage meter to measure whether the total voltage is around 12.5Vdc × the total number of batteries after the batteries are connected in series.
- The default battery quantity is 40 PCS of 12V batteries connected in series. The external battery cabinet's neutral (N) is to be connected to the middle of the 20th and 21st batteries. Please connect the external battery cabinet to the UPS's Battery Input terminals '+', '-' and UPS Output terminal 'N'.

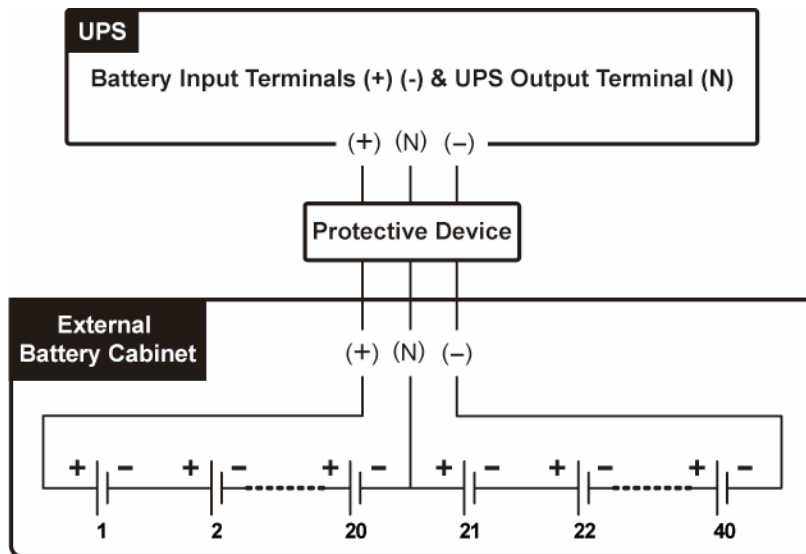

(Figure 5-47: External Battery Cabinet Connection)



WARNING:

The electrolyte leakage of the batteries can lead to serious accidents. For safety's sake, you must insulate the batteries properly (using insulated trays or boxes) from the metal cabinets and racks.

● **Installation of the External Battery Cabinet's Protective Device**

Please follow your UPS rating to install an appropriate protective device for each external battery cabinet. There are four installation methods for selection.

- (1) A 4-pole DC isolated switch connected in series with DC fuses
- (2) A 3-pole DC isolated switch connected in series with DC fuses
- (3) A 4-pole DC circuit breaker connected in series with optional DC fuses
- (4) A 3-pole DC circuit breaker connected in series with optional DC fuses

For relevant values, please refer to **Table 5-4**. for installation diagrams, please refer to **Figure 5-48 ~ Figure 5-51**.

**Table 5-4: External Battery Cabinet's Protective Device
(Default Battery Q'ty: 12Vdc × 40 PCS)**

UPS Rating	Protective Device's Current	Protective Device's Voltage
300kVA/ 300kW	1000A	<ul style="list-style-type: none"> ● 4-pole DC isolated switch/ DC circuit breaker: voltage per pole ≥ 250Vdc. ● 3-pole DC isolated switch/ DC circuit breaker: voltage per pole ≥ 500Vdc ● DC fuse: voltage ≥ 500Vdc
400kVA/ 400kW	1250A	
500kVA/ 500kW	1400A	
600kVA/ 600kW	1700A	



NOTE:

1. **Table 5-4** is for 12Vdc × 40 PCS of the batteries (default). If you install a different number of batteries, please contact Delta service personnel for protective device's current and voltage values.
 2. If you need to parallel multiple units of external battery cabinets, please contact Delta service personnel for relevant information.
 3. To extend the backup time, you can parallel up to four units of external battery cabinets to the UPS. Please note that (1) the number of the batteries in each paralleled external battery cabinet and (2) the cable length of each battery string must be the same.
- When choosing the external battery cabinet's protective device, please take the following factors into consideration: (1) overcurrent between the UPS and battery circuit, (2) short circuit current of the batteries, (3) wire/ cable materials, and (4) local electrical regulations. If you have any questions about the external battery cabinet's protective device, please contact Delta service personnel.

- The protective device is optional, and its type must be fast-acting DC circuit breaker and/ or fast-acting DC fuse. If you want to buy any of them, please contact Delta service personnel. When choosing the protective device, follow the instructions below.
 - (1) The protective device's rated current must comply with the current values shown in **Table 5-4**.
 - (2) The specifications of the protective device's short-circuit protection (i.e. the tripping current of the fast-acting DC circuit breaker and/ or the melting current of the fast-acting DC fuse) must be 4 ~ 6 times the values shown in **Table 5-4**. Besides, the response time of the protective device must be less than 20ms.
 - (3) For the choice of the fast-acting DC fuse mentioned above, the A50QS series from the supplier **Ferraz Shawmut** is suggested. Please contact Delta customer service for relevant information.
 - (4) The maximum tripping current of the fast-acting DC circuit breaker and/ or the maximum melting current of the fast-acting DC fuse mentioned above are 6 times as much as the values shown in **Table 5-4**. These maximum values are suggested for general applications only. For the actual maximum values, the maximum short-circuit capacity of the on-site batteries must be taken into consideration. Please contact Delta customer service for relevant information.

External Battery Cabinet's Protective Device (Option 1)

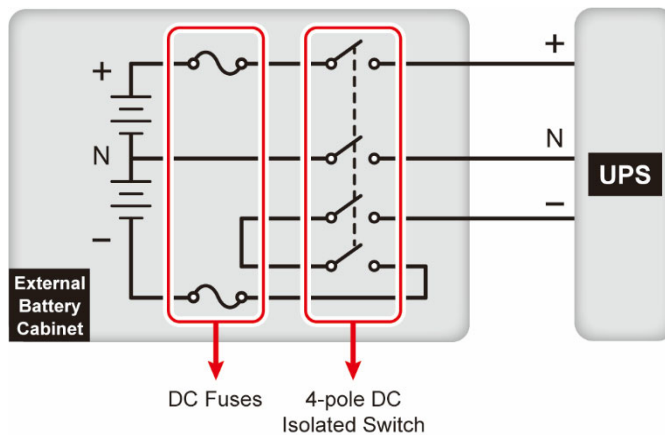

(Figure 5-48: Installation of a 4-pole DC Isolated Switch in Series with DC Fuses)

External Battery Cabinet's Protective Device (Option 2)

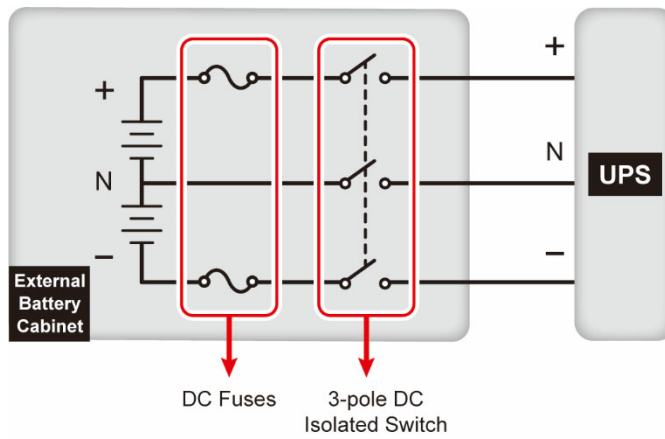

(Figure 5-49: Installation of a 3-pole DC Isolated Switch in Series with DC Fuses)

External Battery Cabinet's Protective Device (Option 3)

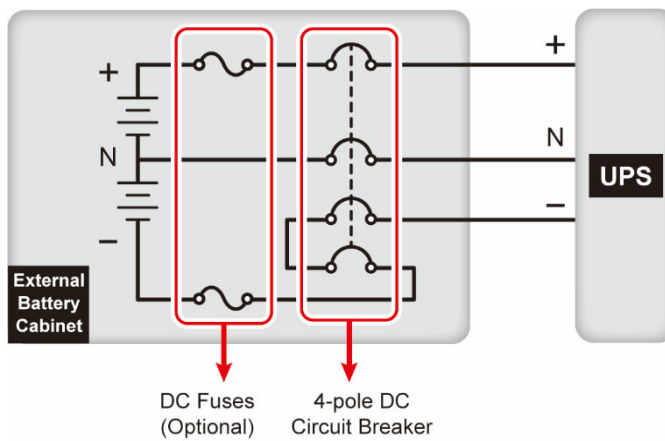

(Figure 5-50: Installation of a 4-pole DC Circuit Breaker in Series with Optional DC Fuses)

External Battery Cabinet's Protective Device (Option 4)

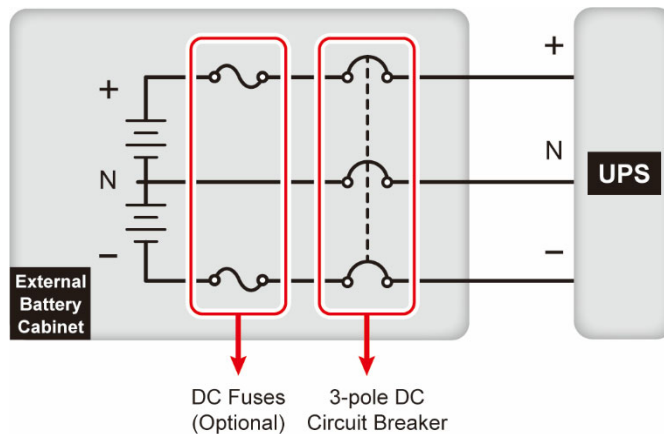

(Figure 5-51: Installation of a 3-pole DC Circuit Breaker in Series with Optional DC Fuses)

● Common Battery (Only for Parallel UPSs Sharing the Same External Battery Cabinet(s))

To save on your costs and installation space, the parallel UPSs can share their connected external battery cabinet(s). See **Figure 5-52** for two parallel UPSs sharing one external battery cabinet as an example.



NOTE:

The following 'common battery' information is not applicable to the UPS using lithium-ion batteries. For relevant information, please refer to the user manual of the lithium-ion batteries. Whether you use the lead-acid batteries or the lithium-ion batteries, please contact Delta service personnel for any battery/ battery cabinet's setup and configurations.

For common battery application, please install a protective device between each parallel UPS and its connected external battery cabinet(s).

If the parallel UPSs share the external battery cabinet(s), you have to set each UPS's '**Float Charge Voltage**' (default: 272V) the same, '**Equalized Charge Voltage**' (default: 280V) the same, and each UPS's '**Battery Strings**' and '**Charge Current (Max)**' even on the LCD. Please refer to the examples below and **7. LCD Display & Settings**.

Example I When (1) two UPSs are paralleled and share one external battery cabinet, (2) lead-acid batteries are used, (3) the battery capacity is 200AH, (4) there are a total of 4 battery strings, and (5) the charge current is 80A, please use the LCD to set each UPS's '**Battery Type**' as '**VRLA**', '**Capacity**' as 200AH, '**Battery Strings**' as 2, and '**Charge Current (Max)**' as 40A.

Example II When (1) three UPSs are paralleled and share one external battery cabinet, (2) lead-acid batteries are used, (3) the battery capacity is 300AH, (4) there are a total of 3 battery strings, and (5) the charge current is 90A, please use the LCD to set each UPS's '**Battery Type**' as '**VRLA**', '**Capacity**' as 300AH, '**Battery Strings**' as 1, and '**Charge Current (Max)**' as 30A.

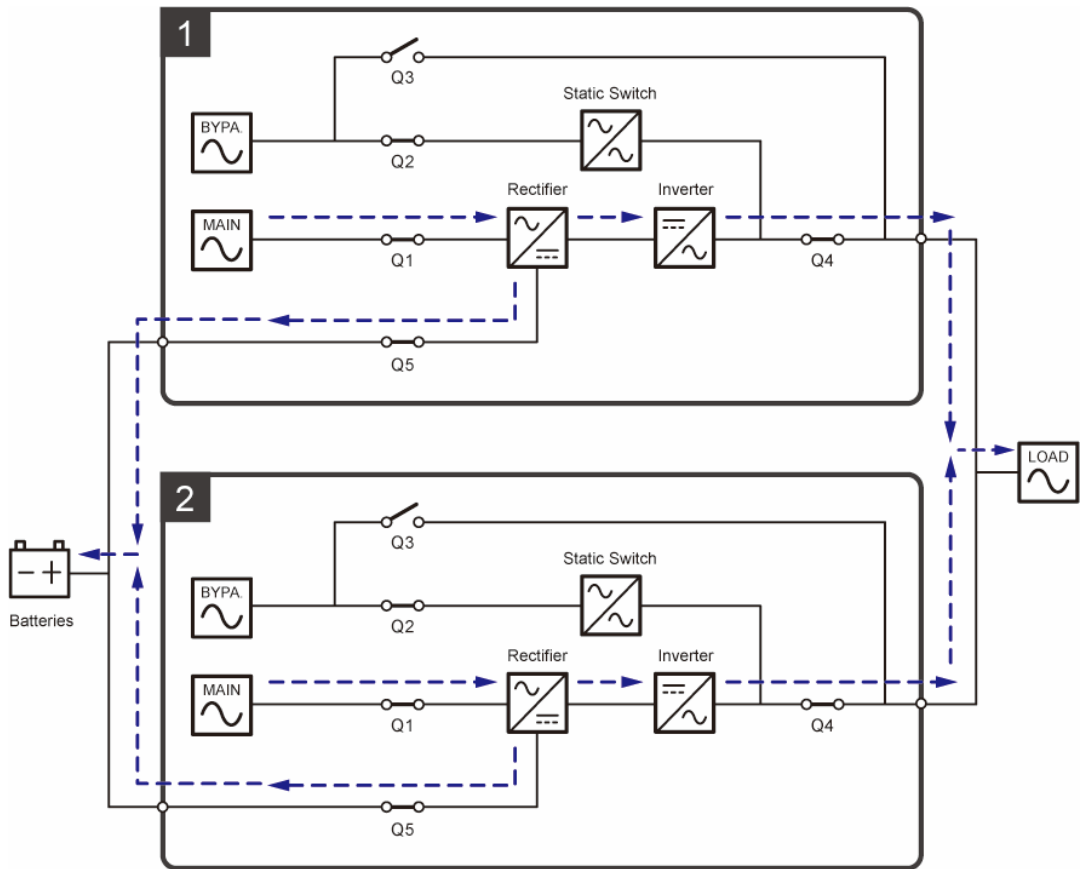

(Figure 5-52: Common Battery Diagram)



WARNING:

1. Before performing battery/ battery cabinet replacement, please turn off each external battery cabinet's breaker (Q5) to completely disconnect the battery power from the UPS.
2. A battery can present a risk of electric shock and high short-circuit current. Servicing of batteries and battery cabinets must be performed or supervised by qualified service personnel knowledgeable in batteries, battery cabinets and the required precautions. Keep unauthorized personnel away from batteries and battery cabinets.

● **External Battery Cabinet Alarm**

When any external battery cabinet connected to the UPS has the following problems, the UPS system will sound an alarm. Please see the table below.

No.	External Battery Cabinet Status	Alarm
1	Battery Abnormal - Reversed	Sounds for 0.5 second every second.
2	Battery Ground Fault	Sounds for 0.5 second every second.
3	Battery Over Temperature	Sounds for 0.5 second every second.
4	Battery Under Temperature	Sounds for 0.5 second every second.
5	Battery Breaker Off	Sounds for 0.5 second every 3 seconds.
6	Battery Disconnected (Missing)	Sounds once every second.
7	Battery Over Charged	Long beep.
8	Battery Test Fail	Sounds for 0.5 second every second.
9	Battery End of Discharge Imminent	Sounds for 0.5 second every second.
10	Battery End of Discharge	Long beep.
11	Battery Life Time Expired	Sounds for 0.5 second every 3 seconds.

5.6 Installation of Rodent Shields

To prevent potential hazards posed by rodents, please install the rodent shields (provided) at the bottom of the UPS.

5.6.1 Installation of 300kVA UPS's Rodent Shields

Table 5-5: 300kVA UPS_ Rodent Shield Quantity

Rodent Shield Type	A	B	C
Quantity	1 PC	1 PC	2 PCS

Step 1

Install the rodent shield A to the front bottom of the UPS.

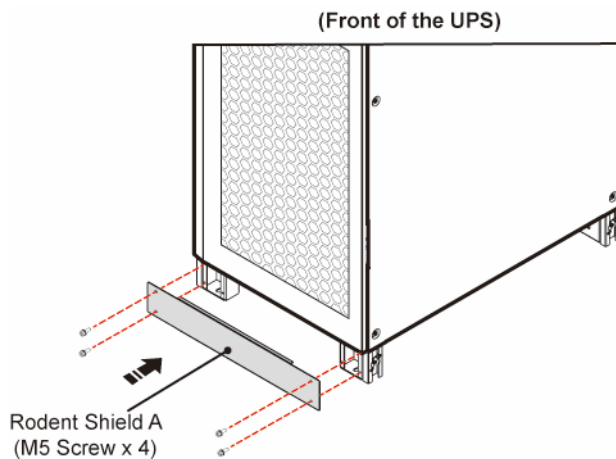

(Figure 5-53: 300kVA UPS_ Install the Rodent Shield A)

Step 2

Install the rodent shield B to the rear bottom of the UPS.

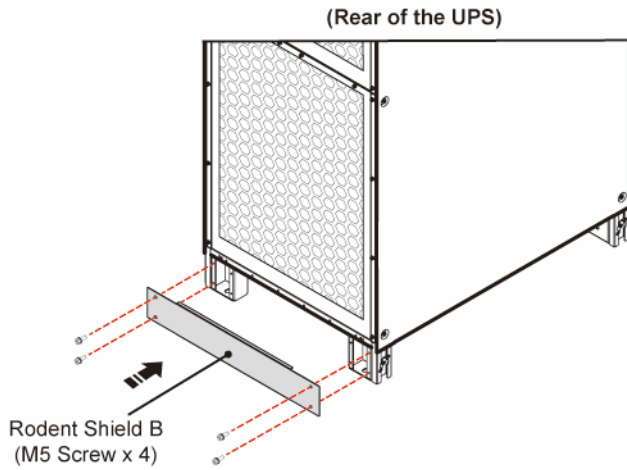

(Figure 5-54: 300kVA UPS_ Install the Rodent Shield B)

Step 3

Install the rodent shields C to the bottom of the two sides.

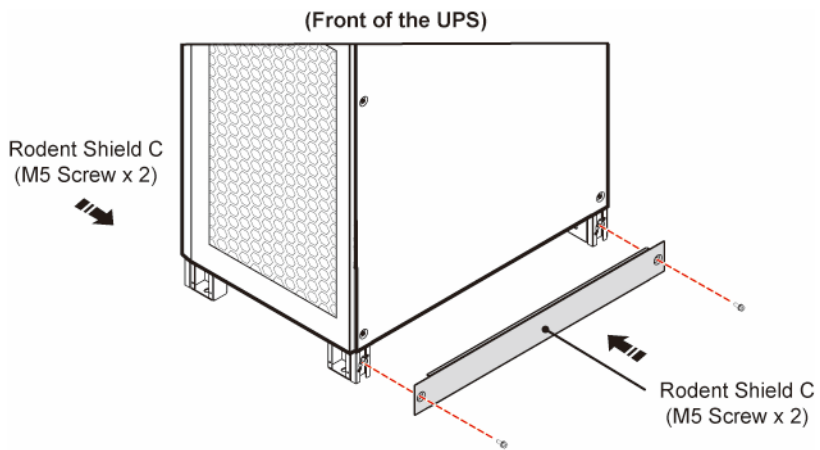

(Figure 5-55: 300kVA UPS_ Install the Rodent Shields C)

5.6.2 Installation of 400/ 500/ 600kVA UPS's Rodent Shields

Table 5-6: 400/ 500/ 600kVA UPS_ Rodent Shield Quantity

Rodent Shield Type	A	B	C	D	E
Quantity	1 PC	1 PC	1 PC	1 PC	2 PCS

Step 1

Install the rodent shields A and B to the front bottom of the UPS.

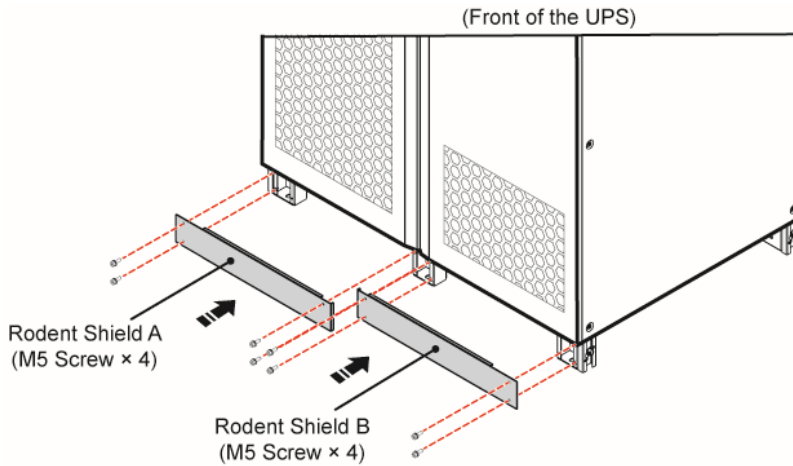

(Figure 5-56: 400/ 500/ 600 kVA UPS_ Install the Rodent Shields A & B)

Step 2

Install the rodent shields C and D to the rear bottom of the UPS.

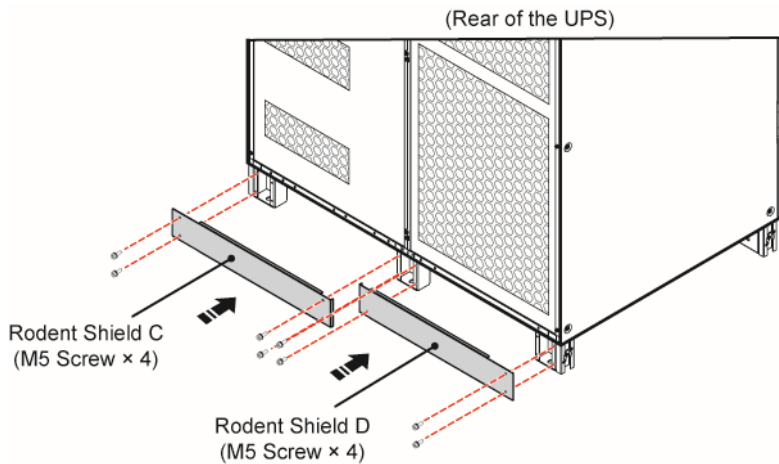

(Figure 5-57: 400/ 500/ 600 kVA UPS_ Install the Rodent Shields C & D)

Step 3

Install the rodent shields E to the bottom of the two sides.

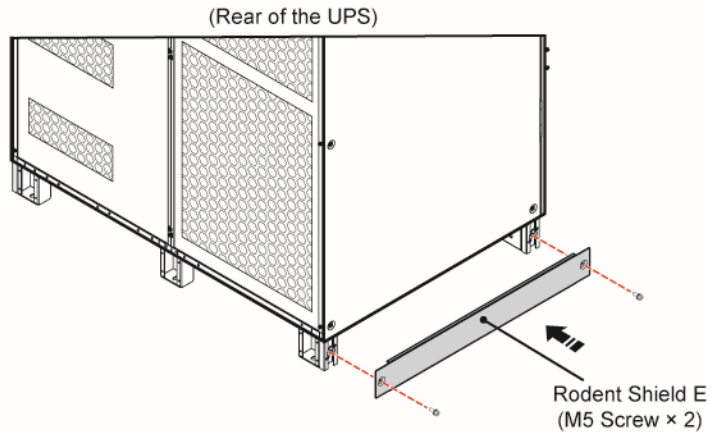

(Figure 5-58: 400/ 500/ 600 kVA UPS_ Install the Rodent Shields E)

Chapter 6 : UPS Operation

6.1 Pre Start-up & Pre Turn-off Warnings



NOTE:

1. All LCD diagrams in the user manual are for reference only. The display is subject to the actual status of the UPS.
2. For information about the LCD touch panel and tri-color LED indicator, please refer to **2.8 Tri-color LED Indicator & Buzzer** and **7. LCD Display & Settings**.
3. If the **ON/ OFF Button** (🔌) does not appear on the screen, please log in as **Administrator** first, and then go to  → **General Setting** → **User** → **On/ Off Button Access** to change the setting.



4. The external battery cabinet's breaker (Q5) shown on the LCD is always **ON** by default. To enable the detection of the Q5 status via the LCD, please contact Delta customer service for additional configurations.

• Pre Start-up Warnings

1. Before UPS operation, ensure that installation and wiring have been completely done according to **5. Installation and Wiring**, and relevant precautions and instructions have been followed. Make sure the AC power's voltage, frequency, phase sequence and battery type meet the UPS's requirements.
2. Make sure that all the switches and breakers, including every external battery cabinet's breaker (Q5), are in the **OFF** position.
3. Make sure that the UPS's voltage difference between the Neutral (N) and Ground (⊕) is below 3V.
4. Do not turn off the Output Switch (Q4) while the UPS is operating (in any mode except for the Manual Bypass mode). Otherwise, it may cause abnormalities or damage to the unit.

- **Pre Turn-off Warnings**

1. Before you perform the turn-off procedures, please make sure the critical loads connected to the UPS have already been safely shut down.
2. Please follow the turn-off procedures for each of the operation modes to shut down the UPS and make sure the Output Switch (Q4) is the last one to be turned off. Otherwise, it may cause abnormalities or damage to the unit.

6.2 Start-up Procedures

6.2.1 On-Line Mode Start-up Procedures



WARNING:

Before turning on the UPS, please read **6.1 Pre Start-up & Pre Turn-off Warnings** thoroughly and ensure that the precautions and instructions have been followed.

Step 1

Ensure that the Manual Bypass Switch (Q3) is in the **OFF** position.

Step 2

Switch **ON** every external battery cabinet's breaker (Q5).

Step 3

Switch **ON** the Output Switch (Q4).

Step 4

Switch **ON** the Input Switch (Q1) and Bypass Switch (Q2).

Step 5

Tap the **ON/ OFF Button** () on the LCD screen.

Step 6

After the inverter turns on, the UPS will run in On-Line mode, the LCD screen will show as below, and the tri-color LED indicator will illuminate green.

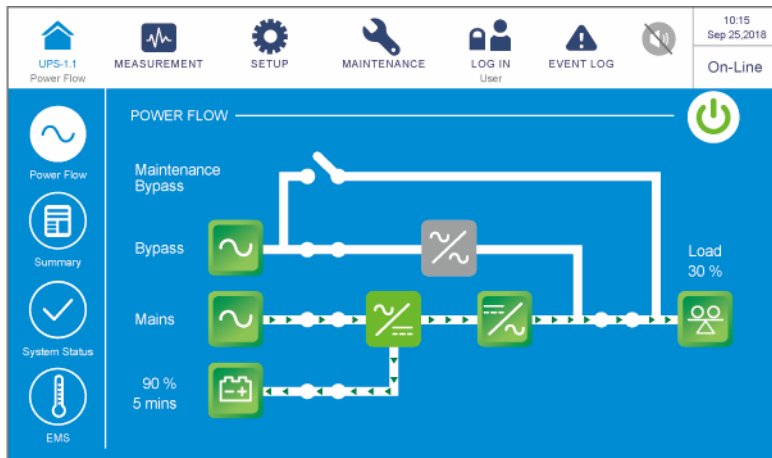

6.2.2 Battery Mode Start-up Procedures



WARNING:

Before turning on the UPS, please read **6.1 Pre Start-up & Pre Turn-off Warnings** thoroughly and ensure that the precautions and instructions have been followed.

Step 1

Ensure that the Manual Bypass Switch (Q3) is in the **OFF** position.

Step 2

Switch **ON** every external battery cabinet's breaker (Q5).

Step 3

Switch **ON** the Output Switch (Q4).

Step 4

Press any of the **BATT. START** buttons on the communication interfaces I for one second.

Step 5

Tap the **ON/ OFF Button** (⏻) on the LCD screen.

Step 6

After the inverter turns on, the UPS will run in Battery mode, the LCD screen will show as below, and the tri-color LED indicator will illuminate yellow.

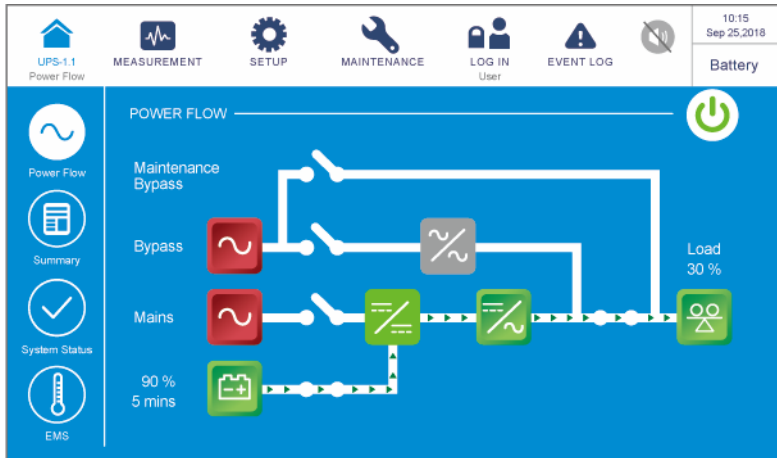

6.2.3 Bypass Mode Start-up Procedures



WARNING:

Before turning on the UPS, please read **6.1 Pre Start-up & Pre Turn-off Warnings** thoroughly and ensure that the precautions and instructions have been followed.

Step 1

Ensure that the Manual Bypass Switch (Q3) is in the **OFF** position.

Step 2

Switch **ON** the Output Switch (Q4).

Step 3

Switch **ON** the Bypass Switch (Q2).

Step 4

Now, the UPS runs in Bypass mode, the LCD screen shows as below, and the tri-color LED indicator illuminates yellow.

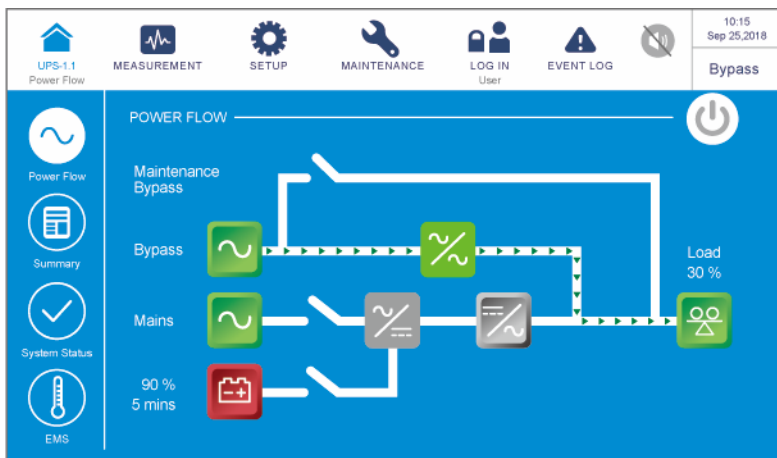

6.2.4 Manual Bypass Mode Start-up Procedures



WARNING:

1. Before turning on/ off the UPS, please read **6.1 Pre Start-up & Pre Turn-off Warnings** thoroughly and ensure that the precautions and instructions have been followed.
2. To enable Manual Bypass mode, please contact Delta customer service for operation.
3. In Manual Bypass Mode, make sure that all of the switches/ breakers (except for the Manual Bypass Switch (Q3)) are in the **OFF** position before working on the UPS's internal circuit to prevent electric shock.

• From On-Line Mode to Manual Bypass Mode

Step 1

Tap the **ON/ OFF Button** () on the LCD screen to shut down the inverter.

Step 2

Ensure that the UPS runs in Bypass mode. After confirmation, turn **ON** the Manual Bypass Switch (Q3).

Step 3

Switch **OFF** the Input Switch (Q1) and Bypass Switch (Q2). After that, the LCD screen shows as follows.

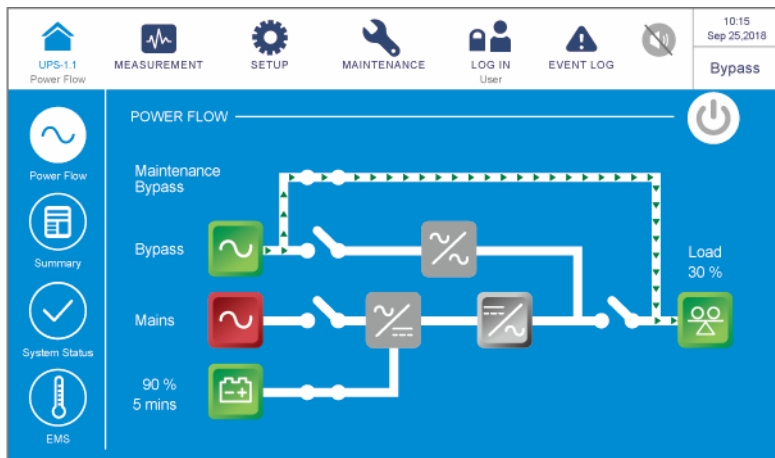

Step 4

Wait for the UPS to complete DC BUS discharging. After discharging, switch **OFF** every external battery cabinet's breaker (Q5), and the LCD and tri-color LED indicator will be off.

Step 5

Switch **OFF** the Output Switch (Q4).

- **From Manual Bypass Mode to On-Line Mode**

Step 1

Switch **ON** every external battery cabinet's breaker (Q5).

Step 2

Switch **ON** the Output Switch (Q4).

Step 3

Switch **ON** the Input Switch (Q1) and Bypass Switch (Q2).

Step 4

Switch **OFF** the Manual Bypass Switch (Q3).

Step 5

Tap the **ON/ OFF Button** (🔌) on the LCD screen.

Step 6

After the inverter turns on, the UPS will run in On-Line mode, the LCD screen will show as below, and the tri-color LED indicator will illuminate green.

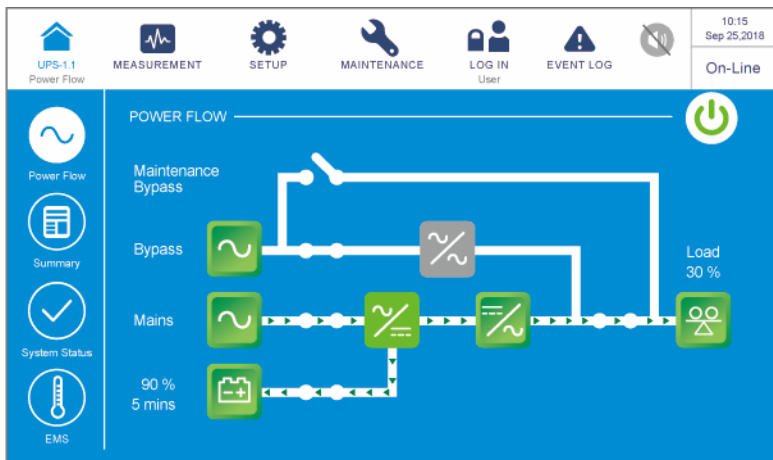

6.2.5 ECO Mode Start-up Procedures



WARNING:

Before turning on the UPS, please read **6.1 Pre Start-up & Pre Turn-off Warnings** thoroughly and ensure that the precautions and instructions have been followed.

Step 1

Ensure that the Manual Bypass Switch (Q3) is in the **OFF** position.

Step 2

Switch **ON** every external battery cabinet's breaker (Q5).

Step 3

Switch **ON** the Output Switch (Q4).

Step 4

Switch **ON** the Input Switch (Q1) and Bypass Switch (Q2). If the bypass input is within the normal range, the UPS will run in Bypass mode.

Step 5

Log in as **Administrator**. For the **Administrator** password, please contact service personnel.

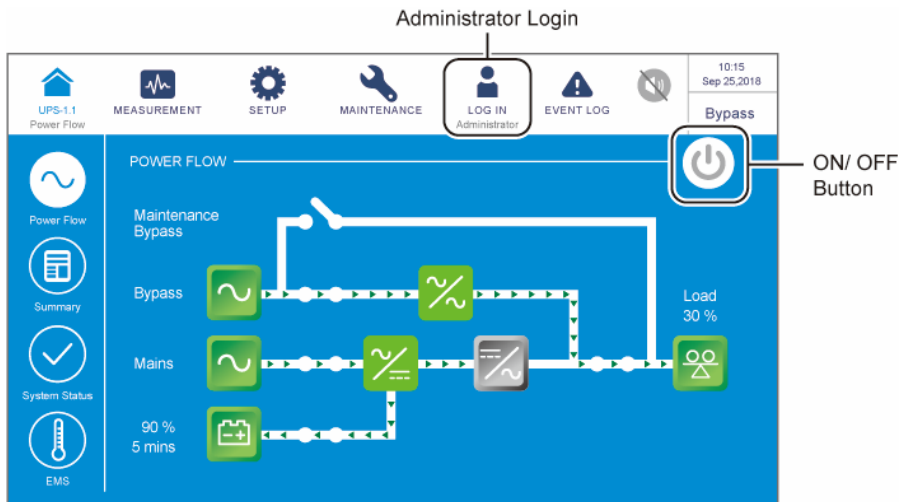

Step 6

Go to **SETUP** → **Mode Setting** → Select **ECO**.

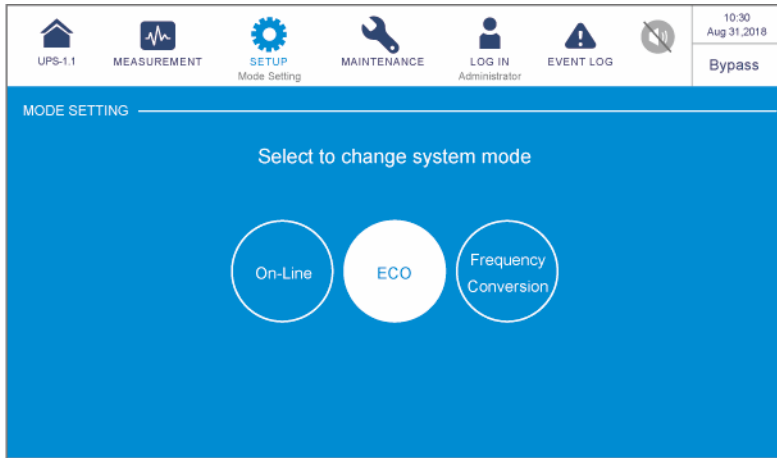

Step 7

Tap the icon (UPS-1.1) to go back to the **Main Screen** and tap the **ON/ OFF Button** (⏻).

Step 8

After the inverter turns on and the system confirms that the bypass voltage is normal, the UPS will automatically transfer to ECO mode to let the bypass supply power, the LCD screen will show as below, and the tri-color LED indicator will illuminate green.

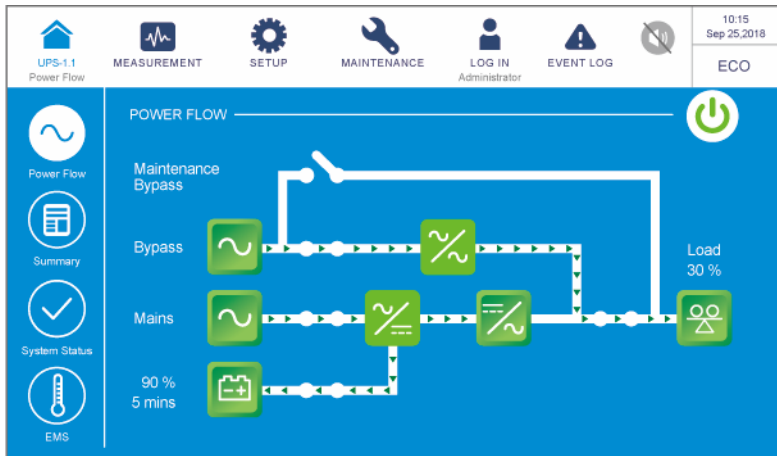

6.2.6 Frequency Conversion Mode Start-up Procedures



WARNING:

1. Before turning on the UPS, please read **6.1 Pre Start-up & Pre Turn-off Warnings** thoroughly and ensure that the precautions and instructions have been followed.
2. Frequency Conversion mode is only applicable to single UPS but not to parallel UPSs.
3. When the UPS runs in Frequency Conversion mode, once the inverter becomes off, there is no bypass power supplying to the loads.

Step 1

Ensure that the Manual Bypass Switch (Q3) is in the **OFF** position.

Step 2

Switch **ON** every external battery cabinet's breaker (Q5).

Step 3

Switch **ON** the Output Switch (Q4).

Step 4

Switch **ON** the Input Switch (Q1) and Bypass Switch (Q2). If the bypass input is within the normal range, the UPS will run in Bypass mode.

Step 5

Log in as **Administrator**. For the **Administrator** password, please contact service personnel.

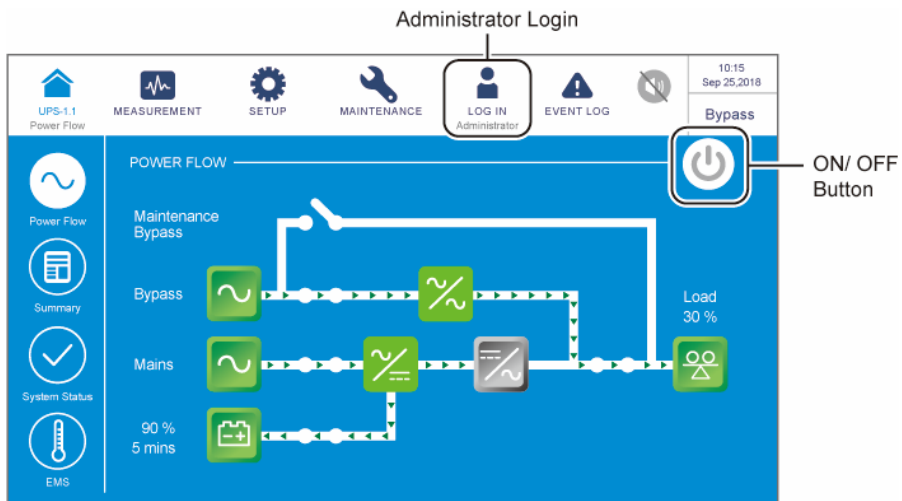

Step 6

Go to **SETUP** → **Mode Setting** → Select **Frequency Conversion**.



WARNING:

Once you select '**Frequency Conversion**' mode, the UPS will run in Standby mode and the output will be terminated.

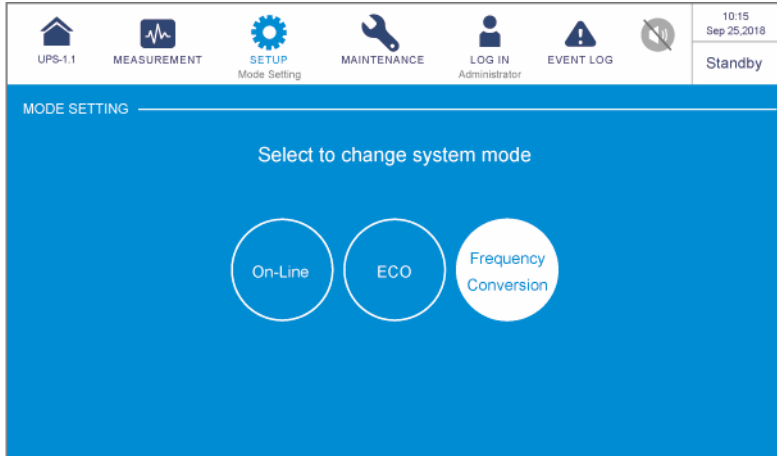

Step 7

Tap the icon (🏠) to go back to the **Main Screen** and tap the **ON/ OFF Button** (🔌).

Step 8

After the inverter turns on, the UPS will run in Frequency Conversion mode, the output frequency will be the same as the setup value, the LCD screen will show as below, and the tri-color LED indicator will illuminate green.

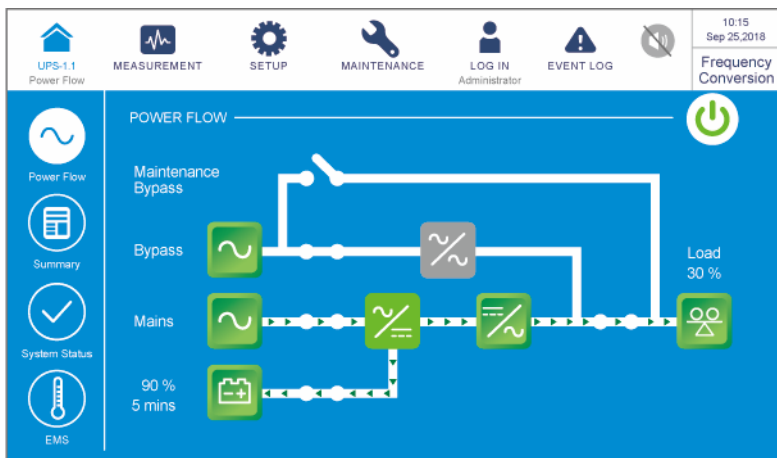

6.3 Turn-off Procedures

6.3.1 On-Line Mode Turn-off Procedures



WARNING:

Before turning off the UPS, please read **6.1 Pre Start-up & Pre Turn-off Warnings** thoroughly and ensure that the precautions and instructions have been followed.

Step 1

Tap the **ON/ OFF Button** () to shut down the UPS's inverter. After that, the UPS will let the bypass AC source supply power. At the moment, if the bypass is abnormal, there is a risk of output interruption.

Step 2

Switch **OFF** the Input Switch (Q1) and Bypass Switch (Q2), and the UPS will transfer to Standby mode.

Step 3

Wait for the UPS to complete the DC BUS discharging. After that, switch **OFF** each external battery cabinet's breaker (Q5), and the LCD screen and tri-color LED indicator will be off.

Step 4

Switch **OFF** the Output Switch (Q4).

6.3.2 Battery Mode Turn-off Procedures



WARNING:

Before turning off the UPS, please read **6.1 Pre Start-up & Pre Turn-off Warnings** thoroughly and ensure that the precautions and instructions have been followed.

Step 1

Tap the **ON/ OFF Button** () to shut down the UPS's inverter. Before that, please make sure the critical loads connected to the UPS have already been safely shut down. Note that once you turn off the inverter, all the output power will be completely cut off, and the UPS will transfer to Standby mode.

Step 2

Switch **OFF** the Input Switch (Q1) and Bypass Switch (Q2).

Step 3

Wait for the UPS to complete the DC BUS discharging. After that, switch **OFF** each external battery cabinet's breaker (Q5), and the LCD and tri-color LED indicator will be off.

Step 4

Switch **OFF** the Output Switch (Q4).

6.3.3 Bypass Mode Turn-off Procedures



WARNING:

Before turning off the UPS, please read **6.1 Pre Start-up & Pre Turn-off Warnings** thoroughly and ensure that the precautions and instructions have been followed.

Step 1

Switch **OFF** the Input Switch (Q1) and Bypass Switch (Q2), and the UPS will transfer to Standby mode.

Step 2

Wait for the UPS to complete the DC BUS discharging. After that, switch **OFF** each external battery cabinet's breaker (Q5), and the LCD and tri-color LED indicator will be off.

Step 3

Switch **OFF** the Output Switch (Q4).

6.3.4 Manual Bypass Mode Turn-off Procedures



WARNING:

1. Ensure that the LCD, all LED indicators and fans are **OFF**.
2. Check that all the switches, breakers and power are **OFF**.

In Manual Bypass mode, the LCD and tri-color LED indicator are both **OFF**. To completely shut down the UPS, switch **OFF** the Manual Bypass Switch (Q3).

6.3.5 ECO Mode Turn-off Procedures



WARNING:

Before turning off the UPS, please read **6.1 Pre Start-up & Pre Turn-off Warnings** thoroughly and ensure that the precautions and instructions have been followed.

Step 1

Tap the **ON/ OFF Button** () to shut down the UPS's inverter. After that, the UPS will let the bypass AC source supply power. At the moment, if the bypass is abnormal, there is a risk of output interruption.

Step 2

Switch **OFF** the Input Switch (Q1) and Bypass Switch (Q2), and the UPS will transfer to Standby mode.

Step 3

Wait for the UPS to complete the DC BUS discharging. After that, switch **OFF** each external battery cabinet's breaker (Q5), and the LCD and tri-color LED indicator will be off.

Step 4

Switch **OFF** the Output Switch (Q4).

6.3.6 Frequency Conversion Mode Turn-off Procedures



WARNING:

Before turning off the UPS, please read **6.1 Pre Start-up & Pre Turn-off Warnings** thoroughly and ensure that the precautions and instructions have been followed.

Step 1

Tap the **ON/ OFF Button** () to shut down the UPS's inverter. Before that, please make sure the critical loads connected to the UPS have already been safely shut down. Note that once you turn off the inverter, all the output power will be completely cut off, and the UPS will transfer to Standby mode. Now, the power modules keep charging the batteries.

Step 2

Switch **OFF** the Input Switch (Q1) and Bypass Switch (Q2), and the UPS will transfer to Standby mode.

Step 3

Wait for the UPS to complete the DC BUS discharging. After that, switch **OFF** each external battery cabinet's breaker (Q5), and the LCD and tri-color LED indicator will be off.

Step 4

Switch **OFF** the Output Switch (Q4).

6.4 Start-up & Turn off Procedures for Parallel Units



WARNING:

1. Before turning on the UPS, please read **6.1 Pre Start-up & Pre Turn-off Warnings** thoroughly and ensure that the precautions and instructions have been followed.
2. Ensure that every operation procedure is synchronized to all parallel UPSs. If you just want to operate a specific UPS but not all the parallel ones, please contact service personnel.

• **Start-up Procedures (Parallel Units)**

Step 1

Ensure that each parallel cable (provided) is connected well.

Step 2

Perform the first few steps following your chosen mode's section in **6.2 Start-up Procedures** until there is power supplying to the UPS (after switching **ON** Q1/ Q2 or pressing the **BATT. START** button).

At this moment, please perform the following parallel settings on the LCD.

- a. Assign a different **Parallel ID** no. to each parallel UPS. For all the parallel UPSs, please set the same **Parallel Group ID** no. and the same parameters for the input, output and battery settings.

- b. Tap the icon () to check if the **Parallel Group ID** no. and **Parallel ID** no. are set properly. The UPS with the smallest **Parallel ID** no. is the master UPS.

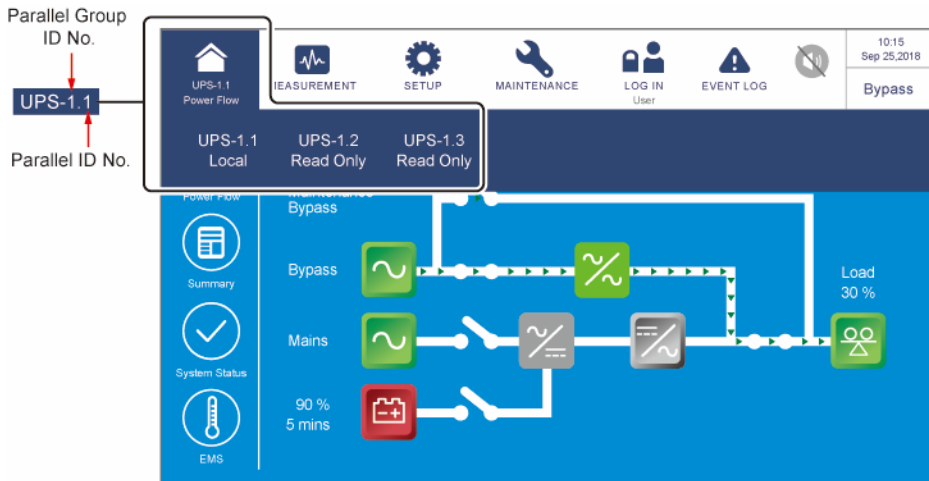

Step 3

Complete the rest of the steps in **6.2 Start-up Procedures** according to your chosen mode.

Step 4

Ensure that the output voltage difference between each parallel UPS is below 3V. Only authorized Delta engineers or service personnel can check the output voltage difference, or it must be done under the supervision of authorized Delta engineers or service personnel.

Step 5

Now, the UPSs are ready to operate in parallel.

- **Turn-off Procedures (Parallel Units)**



WARNING:

To turn off one of the parallel UPSs, please check whether the remaining parallel units' total capacity exceeds the total critical loads. Otherwise, all parallel units will shut down due to overload. Before doing this, please contact service personnel.

Perform the steps following your chosen mode's section in **6.3 Turn-off Procedures**. Make sure to synchronize each step to all the parallel UPSs.

Chapter 7 : LCD Display & Settings

7.1 LCD Display Hierarchy

Please refer to **Figure 7-1** for an overview of all the LCD items. For some of the items marked with an asterisk, they will show up only under certain conditions. Please refer to the note below for details.

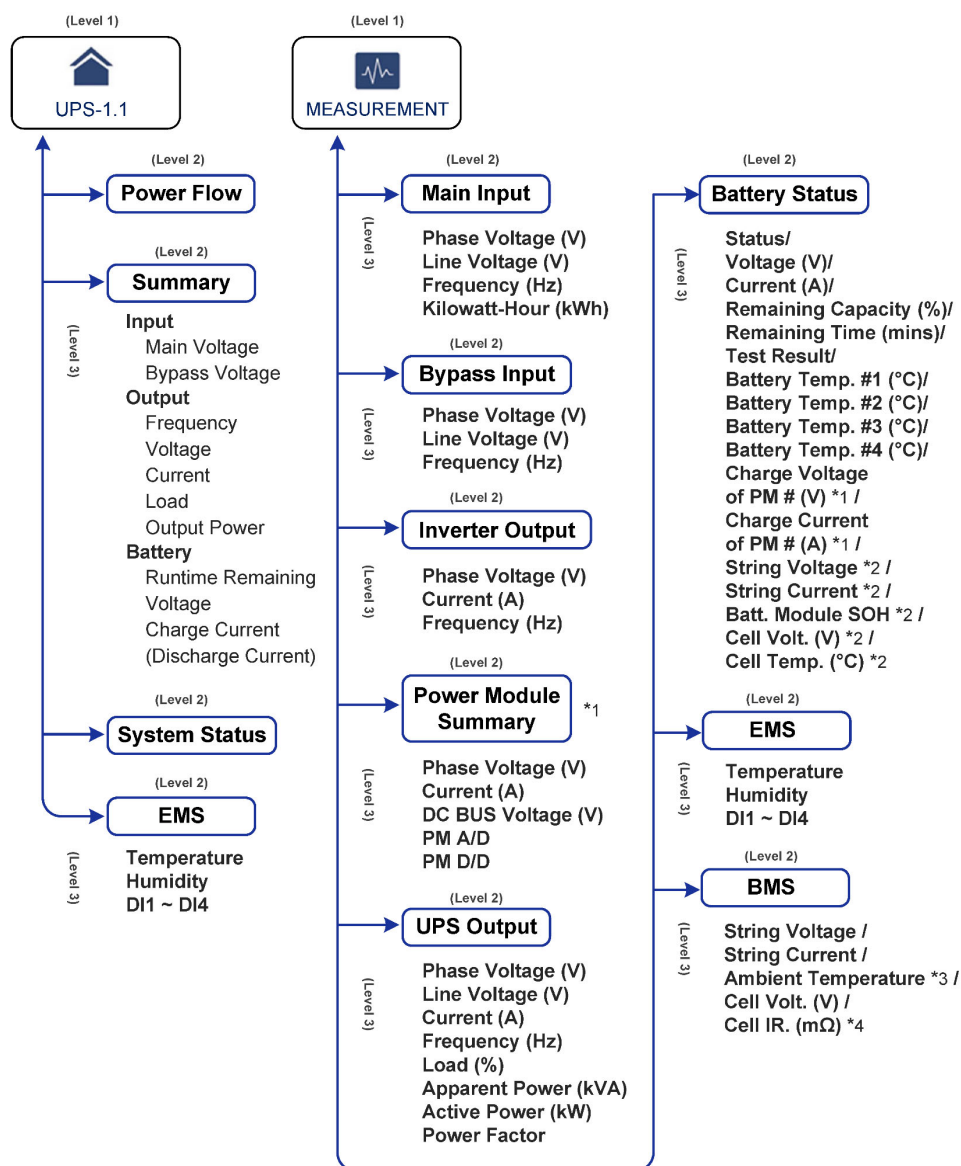

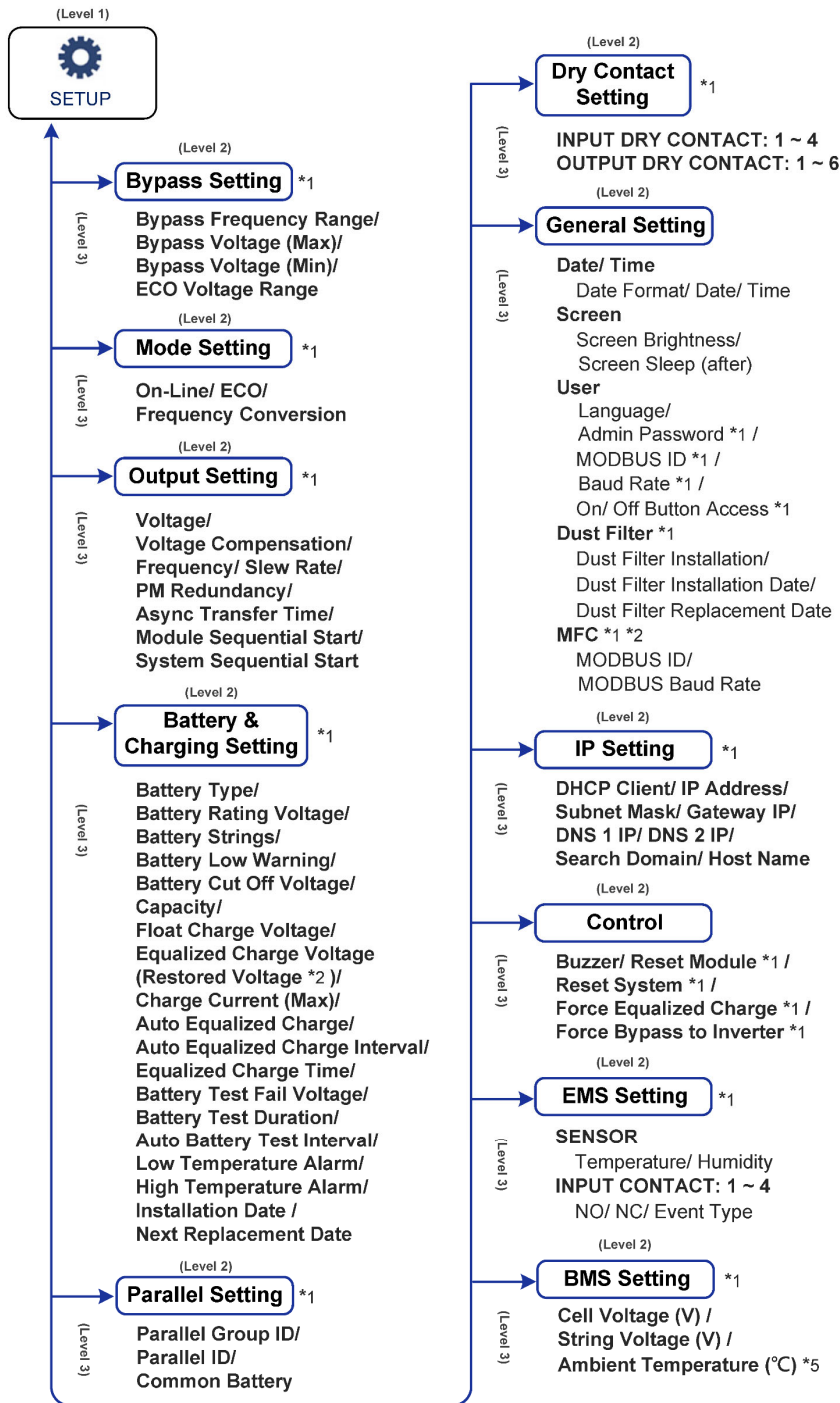

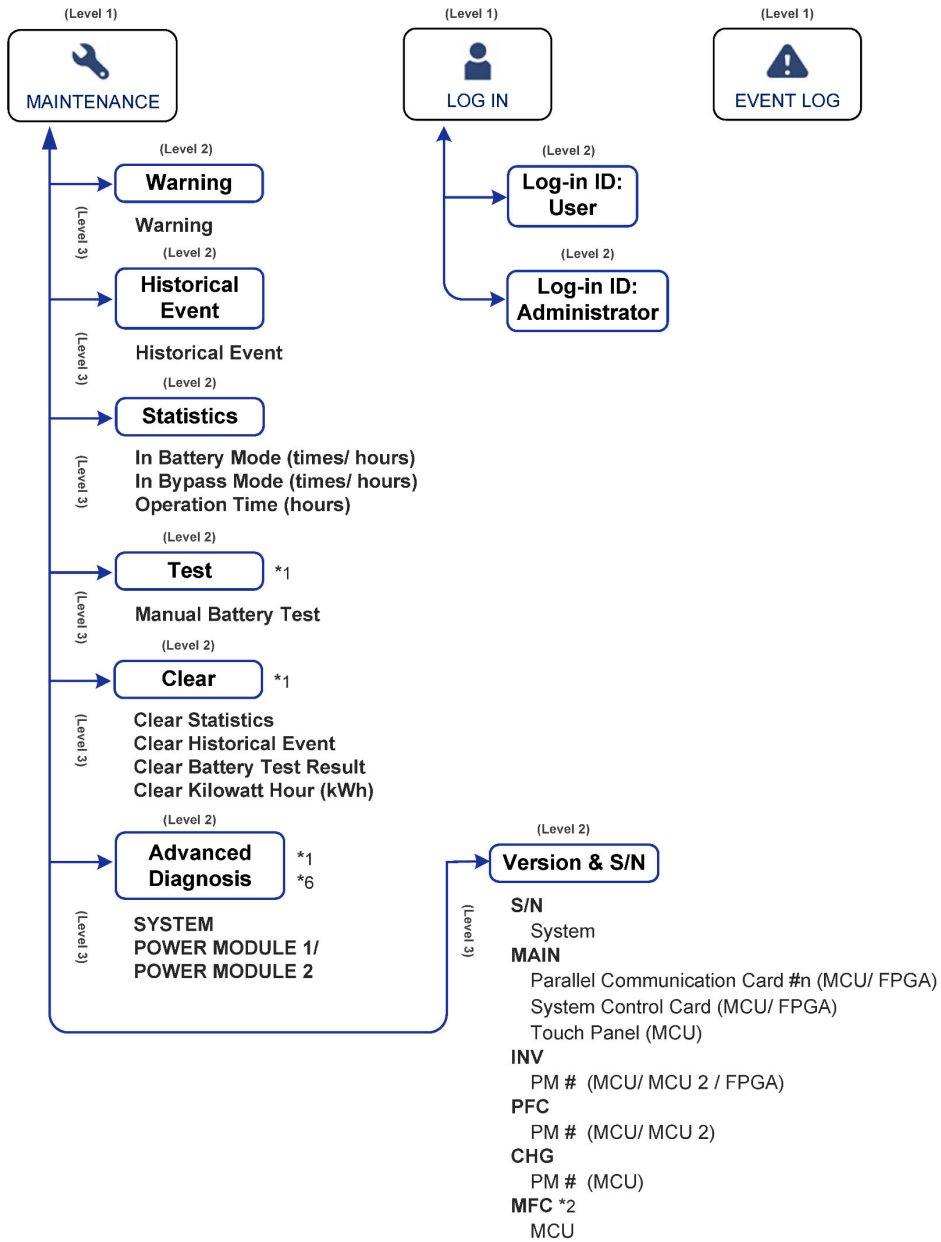



(Figure 7-1: LCD Display Hierarchy)



NOTE:

1. For **BMS/ BMS Setting** and **EMS/ EMS Setting**, the functions will be activated only after proper installation and settings of the optional accessories have been completed. For details, refer to **8. Optional Accessories**.
2. *¹ To display the item(s), you have to log in as **Administrator**. Please refer to **7.4 Password Entry**.
*² The item(s) will show up only when you use the Delta lithium-ion batteries and have installed the optional multifunctional communication card (MFC) in the SMART slot.
*³ To display the item, go to  → **BMS** and select 'Main' from the list in the upper left corner of the screen.
*⁴ To display the item, go to  → **BMS Setting** and select 'Internal Resistance' from the **Module Type** list.
*⁵ To display the item, go to  → **BMS Setting** and select 'Main' from the **Module** list.
*⁶ This function is optional. If you need to activate it, please contact Delta customer service.
3. The LCD screen diagrams in the user manual are for reference only. The actual display depends on the operation situation.

7.2 How to Turn on the LCD

Step 1

Turn on the Output Switch (Q4).



Step 2

Perform one of the options (a ~ d) below; after that, the LCD will be on.

- a. Turn on the Input Switch (Q1); or
- b. Turn on the Bypass Switch (Q2); or
- c. Turn on the Input Switch (Q1) and Bypass Switch (Q2); or
- d. Turn on any external battery cabinet's breaker (Q5) and press any of the battery start buttons (see **Figure 4-1**) for 1 second.

Step 3





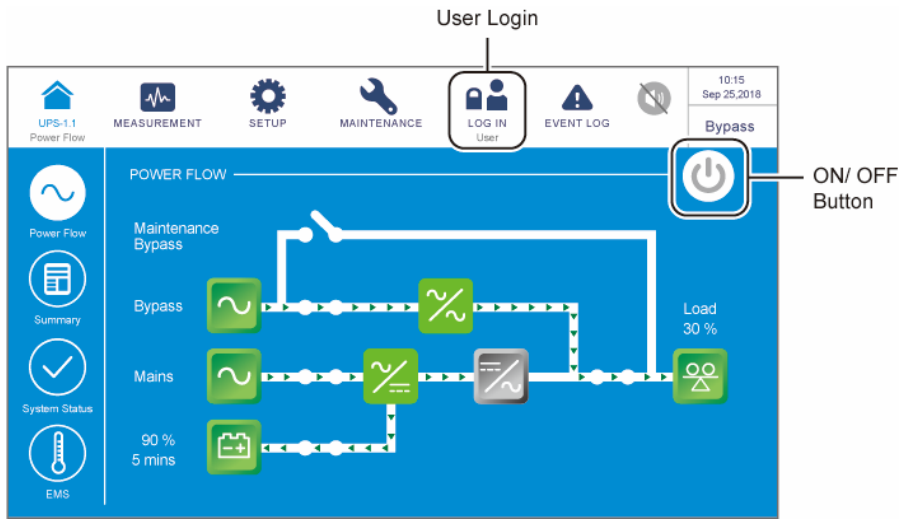

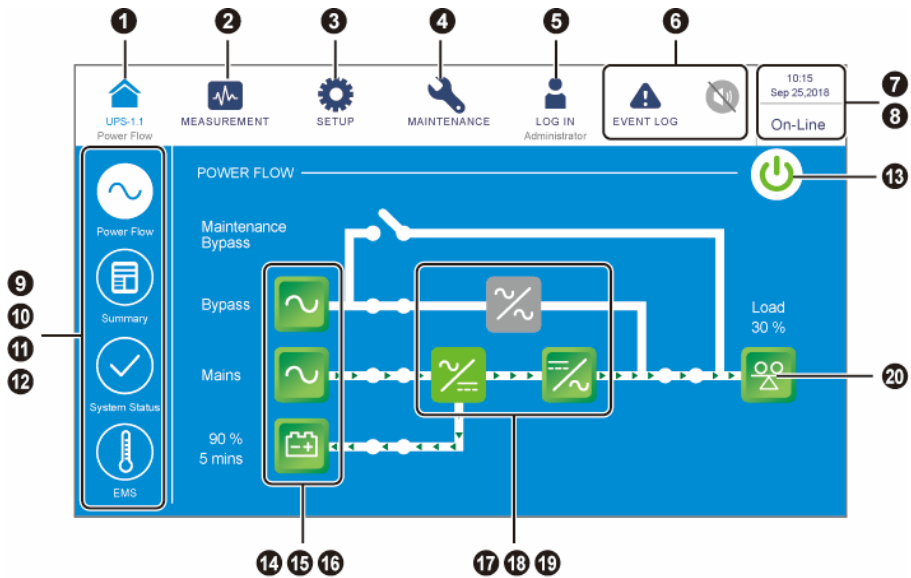

A short while later, the **Main Screen** will appear with **User Login** status and the **ON/ OFF Button** (.















If the **ON/ OFF Button** () does not appear on the screen, please log in as **Administrator** first, and then go to  → **General Setting** → **User** → **On/ Off Button Access** to change the setting.













7.3 Introduction of Touch Panel and Function Keys













No.	Icon/ Text	Button Function (Yes or No)	Text/ Digital Display (Yes or No)	Symbol Display (Yes or No)	Description
1		✓	✓		<p>Tap the button to go back to the Main Screen. The figure (<i>UPS-1.1</i>) below the icon () indicates the parallel group ID no. (the former one) and the parallel ID no. (the latter one).</p> <p> NOTE: On the master UPS's screen, you can not only check its own status and readings but also the slave UPSs' partial status and readings. On a slave UPS's screen, you can only check its own status and readings.</p>
2		✓			Tap the button to open the measurement menu. For the menu items, refer to Figure 7-1 .
3		✓			Tap the button to open the setup menu. For the menu items, refer to Figure 7-1 . For details, refer to 7.6 UPS Setting .
4		✓			Tap the button to open the maintenance menu. For the menu items, refer to Figure 7-1 . For details, refer to 7.7 System Maintenance .
5		✓		✓	Indicates User login status. Tap the icon to change the login permission. Please refer to 7.4 Password Entry .
		✓		✓	Indicates Administrator login status. Tap the icon to change the login permission. Please refer to 7.4 Password Entry .







No.	Icon/ Text	Button Function (Yes or No)	Text/ Digital Display (Yes or No)	Symbol Display (Yes or No)	Description
6		✓		✓	<ol style="list-style-type: none"> 1. Historical event screen shortcut button () (<small>EVENT LOG</small>). 2. When the icon is blue (), it means there is no warning event.
		✓	✓	✓	<ol style="list-style-type: none"> 1. Warning screen shortcut button () & buzzer icon (). 2. When the icon is red (), it indicates there is a warning event. At this time, the buzzer will sound and the buzzer icon will appear in red (). The numerical value at the upper right of the icon () indicates the total number of the warning events. To mute the buzzer, tap the icon () , and the icon will become gray (). If there is any new warning event happening afterwards, the buzzer will sound and the icon () will appear and light up again.
7	10:15 Sep 25, 2018		✓		Indicates the time and date.
8	On-Line ECO Frequency Conversion Bypass Battery Standby Softstart		✓		Indicates the UPS's current operation mode.
9		✓			Tap the button to check the power flow diagram and the operation status of the UPS.
10		✓			Tap the button to check the Input , Output , and Battery summary status of the UPS.

No.	Icon/ Text	Button Function (Yes or No)	Text/ Digital Display (Yes or No)	Symbol Display (Yes or No)	Description
11		✓			Tap the button to check the system status, including auxiliary power card status, system control card status and parallel communication card status.
12		✓			Tap the button to check the EMS status. To enable the function, you have to connect an optional EMS 1000 (EnviroProbe) to the UPS and complete relevant settings. For details, refer to 8. Optional Accessories .
13		✓		✓	ON/ OFF Button. The gray icon (⏻) indicates that the inverter is OFF. The green icon (⏻) indicates that the power-on process is completed and the inverter is ON.
14		✓		✓	1. Indicates bypass input status (Green: Normal/ Red: Abnormal or OFF). 2. Bypass input screen shortcut button.
15		✓		✓	1. Indicates main input status (Green: Normal/ Red: Abnormal or OFF). 2. Main input screen shortcut button.
16		✓	✓	✓	1. Indicates battery status (Green: Normal/ Flashing Green & Gray: Battery Mode/ Flashing Red & Gray: Battery Not Connected). 2. Shows battery remaining capacity (%) and battery remaining time (minutes). 3. Battery status screen shortcut button.

No.	Icon/ Text	Button Function (Yes or No)	Text/ Digital Display (Yes or No)	Symbol Display (Yes or No)	Description
17				✓	Indicates bypass static switch status (Green: ON/ Gray: Abnormal or OFF).
18				✓	Indicates rectifier status (Green: Normal/ Gray: Waiting or OFF).
19		✓		✓	1. Indicates inverter status (Green: Normal/ Gray: Waiting or OFF). 2. Inverter output screen shortcut button.
20		✓	✓	✓	1. Indicates output status (Green: Normal/ Gray: No Output). 2. Shows load capacity (%). 3. UPS output screen shortcut button.



Other icons on the touch panel are shown in the table below.

No.	Icon	Function
1		Goes to the top page.
2		Goes to the last page.
3		Moves up.
		
4		Moves down.
		
5		Goes to the previous page.
		
6		Goes to the next page.
		



No.	Icon	Function
7		Increase.
8		Decrease.
9		1. Indicates the page no. 2. Choose to go to a specific page no.
10		Delete.
		
11		Capital.
12		Space.



NOTE:

1. After the backlight is turned off, you can tap the LCD to return to the **Main Screen**.
2. The sleep time for the backlight can be adjusted. Please go to  → **General Setting** → **Screen** → **Screen Sleep (after)**.
3. If you are logged in as **Administrator**, you will be logged out when the backlight is off. Tap to wake up the LCD screen, and it will go back to the **Main Screen** in the **User** login status. Even if you set up the backlight in '**Never Sleep**' mode, you will still be logged out after the screen is idle for 5 minutes.
4. The default language is English (differs according to countries). To change the display language, please go to  → **General Setting** → **User** → **Language**.

7.4 Password Entry

1. **Administrator** login requires a password while **User** login does not.
2. Tap  → enter the **Administrator** password (contact service personnel for the default password) → the icon  appears, indicating the **Administrator** login is successful.
3. To change the **Administrator** password, please go to  → **General Setting** → **User** → **Administrator Password** (4 digits).

7.5 Check Kilowatt-Hour

Path:  → **Main Input** → kWh icon ()

Tap the kWh icon (), and you can check the **kWh statistics** of the UPS main input in the following window.

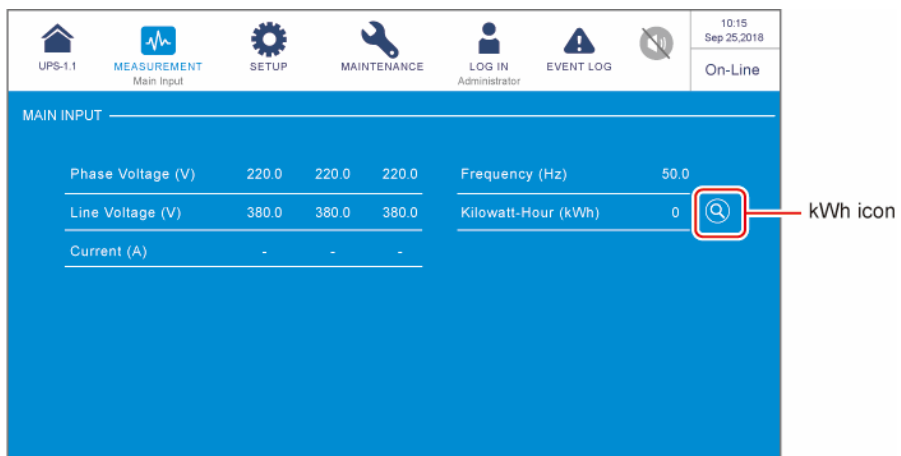

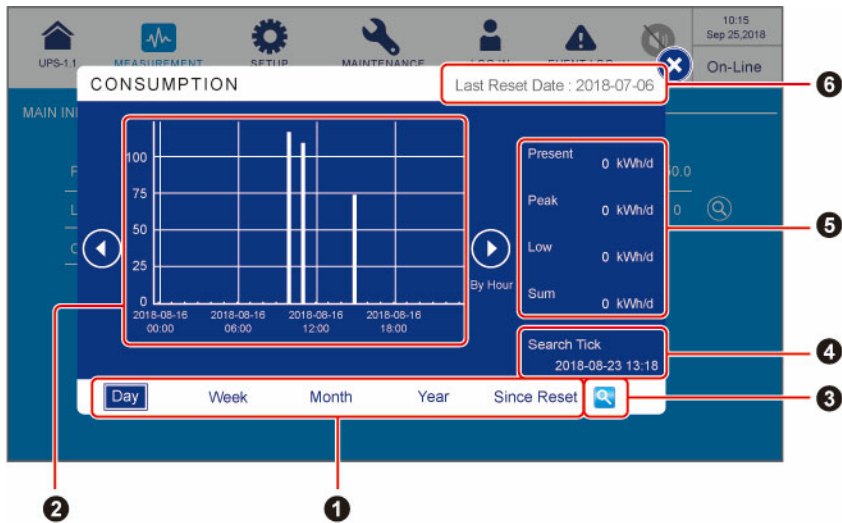

No.	Item	Description
1	Sheet Tabs (Day/ Week/ Month/ Year/ Since Reset)	Tap the sheet tabs to view the kWh statistics and column charts of different time scales.
2	Column Chart	<ol style="list-style-type: none"> Shows the UPS's main input kWh statistics, with time on X-axis and kWh on Y-axis. Tap the column on the chart, and the corresponding piece of data will appear below the chart.
3	Search Tick Setup Icon (🔍)	Tap (🔍), and you can set the date and time for the 'Search Tick' to view the corresponding column chart.
4	Search Tick	Shows the date and time that has been set via (🔍).
5	Present/Peak/ Low/ Sum (kWh/d)	Regardless of different kWh statistics sheets, these four items only indicate today's statistics: the present value/ the highest value (so far)/ the lowest value (so far)/ the sum (so far).
6	Last Reset Date	The last date when 'Clear Kilowatt Hour' was executed.

7.6 UPS Settings

This chapter lists all the UPS setting items for your reference (not including the setting items for the optional accessories). Some items will show up only under certain conditions. Please refer to **7.1 LCD Display Hierarchy** for details.

7.6.1 Bypass Setting

Path:  → Bypass Setting

Item	Description
Bypass Frequency Range	Set up the bypass output's frequency range.
Bypass Voltage (Max.)	Set up the bypass output's maximum voltage.
Bypass Voltage (Min.)	Set up the bypass output's minimum voltage.
ECO Voltage Range	Set up the bypass output's voltage range in ECO mode.

7.6.2 Mode Setting

Path:  → Mode Setting

Item	Description
On-Line Mode	Set up the UPS in On-Line mode. In On-Line mode, it is the inverter to supply power to the connected loads.
ECO Mode	Set up the UPS in ECO mode. In ECO mode, it is the bypass to supply power to the connected loads. It is suggested that you set the UPS in ECO mode only when there is stable main AC power. Otherwise, power supply quality will be compromised.
Frequency Conversion Mode	<p>Set up the UPS in Frequency Conversion mode. In Frequency Conversion mode, it is the inverter to supply power to the connected loads with a fixed output frequency. Please note that the output will be terminated once the inverter is turned off.</p> <p> NOTE: Frequency Conversion mode is only applicable to single UPS but not to parallel UPSs.</p>



7.6.3 Output Setting

Path:  → Output Setting

Item	Description
Voltage	Set up the output voltage.
Voltage Compensation	When the UPS is distant from the loads and there is a voltage drop in the output, you can adjust the INV output voltage amplitude for voltage compensation.
Frequency	Set up the output frequency as 50Hz (default) or 60Hz. The system will automatically select the output frequency in accordance with the bypass power.
Slew Rate	Set up the maximum permissible speed for the system output frequency to catch up the bypass frequency variation.
Power Module Redundancy	Set up how many power modules that need to be preserved for redundancy.
Asynchronous Transfer Time	When it is impossible for the inverter to reach synchronous phase lock with the bypass, the output will be terminated during conversion process according to this setup time.
Module Sequential Start	Set up the time interval for every power module to be converted from the Battery mode to On-Line mode. The setup is applicable to the generator to avoid bearing the whole loads right away.
System Sequential Start	Set up the time interval for the system to be converted from the Battery mode to On-Line mode. The setup is applicable to the generator to avoid bearing the whole loads right away.

7.6.4 Battery & Charging Setting

Path:  → Battery & Charging Setting

Item	Description
<p>Battery Type</p>	<p>Set up the battery type as VRLA/ LiB (Dry Contact)*¹/ LiB (Integration)*².</p> <p> NOTE:</p> <ol style="list-style-type: none"> *¹ If you use non-Delta lithium-ion batteries, please set up the battery type as 'LiB (Dry Contact)'. Please refer to 4.1.6 Input Dry Contacts and 7.6.6 Dry Contact Setting. For more information about configurations of the lithium-ion batteries, please contact Delta customer service. *² If you use the Delta lithium-ion batteries, please set up the battery type as 'LiB (Integration)'. The item 'LiB (Integration)' will only appear on the LCD if you use the Delta lithium-ion batteries with the optional multifunctional communication card (MFC) being installed in the SMART slot. Please contact Delta customer service if you need more information.
<p>Battery Rating Voltage</p>	<p>Set up the battery voltage rating.</p>
<p>Battery Strings</p>	<p>Set up how many battery strings that are used on site.</p>
<p>Battery Low Warning</p>	<p>Set up the battery low warning voltage.</p>
<p>Battery Cut Off Voltage</p>	<p>Set up the battery low voltage. In Battery mode, when the battery low voltage is reached, the battery power will be cut off, the UPS will shut down, and the connected loads will not be protected.</p>
<p>Capacity</p>	<p>Set up the battery capacity.</p>
<p>Float Charge Voltage</p>	<p>Set up the float charge voltage.</p>
<p>Equalized Charge Voltage</p>	<p>Set up the equalized charge voltage.</p> <p> NOTE:</p> <p>The item will only show up if the Battery Type is set as 'VRLA'.</p>

Item	Description
Restored Voltage	Set up the restored voltage.  NOTE: <ol style="list-style-type: none"> 1. The item will only show up if the Battery Type is set as 'LiB (Integration)'. 2. If the Battery Type is set as 'LiB (Dry Contact)', the item will not show up.
Charge Current (Max)	Set up the maximum charge current.
Auto Equalized Charge	Enable or disable the auto-equalized charge.
Auto Equalized Charge Interval	Set up the auto equalized charge interval.
Equalized Charge Time	Set up the equalized charge time.
Battery Test Fail Voltage	Set up the battery test fail voltage. When the battery voltage is under the test fail voltage, it means battery fail.
Battery Test Duration	Set up how long the battery test should last.
Auto Battery Test Interval	Set up the battery test interval.
Low Temperature Alarm	Enable or disable the low temperature alarm. If enabled, set up the temperature.
High Temperature Alarm	Enable or disable the high temperature alarm. If enabled, set up the temperature.
Installation Date	Record the battery installation date.
Next Replacement Date	Set up the battery replacement date.

7.6.5 Parallel Setting

Path:  → Parallel Setting

Item	Description
Parallel Group ID	The UPSs in parallel connection must be assigned the same parallel group ID no. in order to let the outputs of the parallel UPSs be put in parallel connection and let the loads be evenly distributed among the parallel units. If the parallel UPSs have different parallel group ID no., their output signals might be synchronized but their outputs cannot be connected in parallel.
Parallel ID	The UPSs that need to be paralleled must be assigned the same parallel group ID no. and different parallel ID no. in order to let the parallel function work.
Common Battery	If the parallel UPSs that have the same parallel group ID no. need to share common batteries, please select ' Enable ' for the ' Common Battery ' setup item. Otherwise, the function of battery abnormality detection will fail. For more information about common battery, please refer to 5.5 External Battery Cabinet Connection Warnings .

7.6.6 Dry Contact Setting





Path:  → Dry Contact Setting

Input Dry Contact No.	Event Selection	Type
Input Dry Contact 1 Input Dry Contact 2 Input Dry Contact 3 Input Dry Contact 4	1. None 2. Generator Status 3. Battery Ground Fail 4. External Battery Breaker Detection 5. Charge Off (Positive) 6. Charge Off (Negative) 7. Battery Abnormal Shutdown 8. Input Transformer OTW 9. Output Transformer OTW 10. Battery Fuse Open	Set up NO (normally open) or NC (normally closed) for each input dry contact.

Output Dry Contact No.	Event Selection	Type
Output Dry Contact 1 Output Dry Contact 2 Output Dry Contact 3 Output Dry Contact 4 Output Dry Contact 5 Output Dry Contact 6	1. None 2. Load On Inverter 3. Load On Bypass 4. Load On Battery 5. Battery Low 6. Battery Input Abnormal 7. Battery Test Fail 8. Internal Comm. Fail 9. External Parallel Comm. Fail (only applicable to parallel application) 10. Output Overload 11. EPO Activated 12. Load On Manual Bypass 13. Battery Over Temperature 14. Output Voltage Abnormal 15. Battery Need Replacement 16. Bypass Over Temperature 17. Bypass Static Switch Fault 18. UPS Over Temperature 19. Battery Breaker Shunt Trip 20. Backfeed Protection 21. UPS General Alarm	Set up NO (normally open) or NC (normally closed) for each output dry contact.

7.6.7 General Setting

Path:  → General Setting

Item	Sub Item	Description
DATE/ TIME	Date Format	Select the date format.
	Date	Set up the date.
	Time	Set up the time.
SCREEN	Screen Brightness	Adjust the LCD display brightness (default: 80).
	Screen Sleep (after)	Set up the LCD backlight sleep time (default: 1 minute).
USER	Language	Set up the display language (default: English).
	Admin Password	Set up the administrator password (4 digits).
	MODBUS ID	Set up the MODBUS ID for the MODBUS port located at the rear of the touch panel.
	Baud Rate	Set up the baud rate for the MODBUS port located at the rear of the touch panel.
	On/ Off Button Access	Set up the access for the ON/ OFF Button () as ' Any User ' or ' Administrator Only '.
DUST FILTER	Dust Filter Installation	If you have installed any dust filter, please select ' Enable '; if not, please select ' Disable '.
	Dust Filter Installation Date	Set up the dust filter installation date.  NOTE: Only when you select ' Enable ' for ' Dust Filter Installation ' can you set up the item.
	Dust Filter Replacement Date	Set up the dust filter replacement date. When the date is due, the red warning icon () will automatically appear in the upper right corner of the LCD, and the alarm message ' Replace Dust Filter ' will be displayed.  NOTE: Only when you select ' Enable ' for ' Dust Filter Installation ' can you set up the item.

7.6.8 IP Setting

Path:  → IP Setting

Item	Description
DHCP Client	Enable or disable the DHCP client.
IP Address	Set up the IP address.
Subnet Mask	Set up the subnet mask.
Gateway IP	Set up the gateway IP address.
DNS 1 IP	Set up the DNS server 1 IP address.
DNS 2 IP	Set up the DNS server 2 IP address.
Search Domain	Set up the search domain.
Host Name	Set up the host name.

7.6.9 Control



Path:  → Control

Item	Description
Buzzer	Enable or disable the buzzer.
Reset Module	Reset the power modules or not. In Bypass mode, when you tap the ON/ OFF Button (⏻) to start up the UPS but the UPS does not respond, please select ' Reset ' to reset the power modules. After the power modules are reset, please tap the ON/ OFF Button (⏻) to start up the UPS.
Reset System	Reset the system or not. In Bypass mode, when you tap the ON/ OFF Button (⏻) to start up the UPS but the UPS does not respond, please select ' Reset ' to reset the system. After the system is reset, please tap the ON/ OFF Button (⏻) to start up the UPS.
Force Equalized Charge	Manually force the UPS to run in auto equalized charge mode to charge the batteries.
Force Bypass to Inverter	Manually force the UPS to switch from bypass to inverter when the inverter keeps staying in the soft-start status and is unable to transfer to On-Line mode successfully.

7.7 System Maintenance

7.7.1 Warning

Path 1:  → **Warning**

Path 2: When there is a warning, the buzzer icon () will light up in red, and the buzzer will sound. Tap the warning icon () to enter the **WARNING** screen.

The system can store a maximum of 200 warning logs.

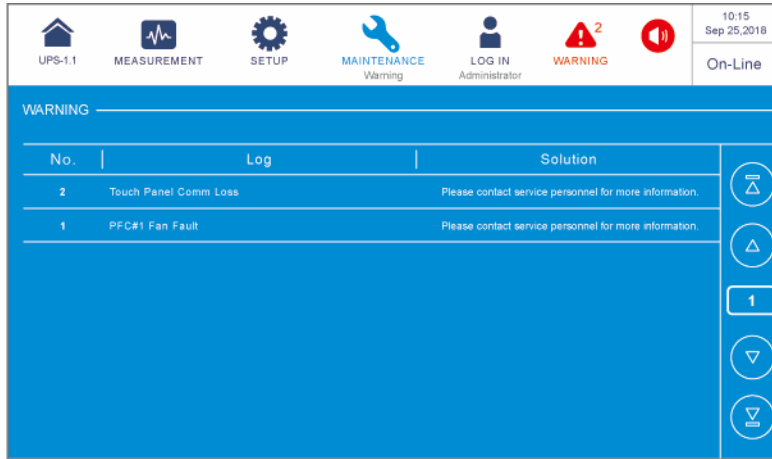

No.	Log	Solution
2	Touch Panel Comm Loss	Please contact service personnel for more information.
1	PFC#1 Fan Fault	Please contact service personnel for more information.

7.7.2 Historical Event

Path:  → **Historical Event**

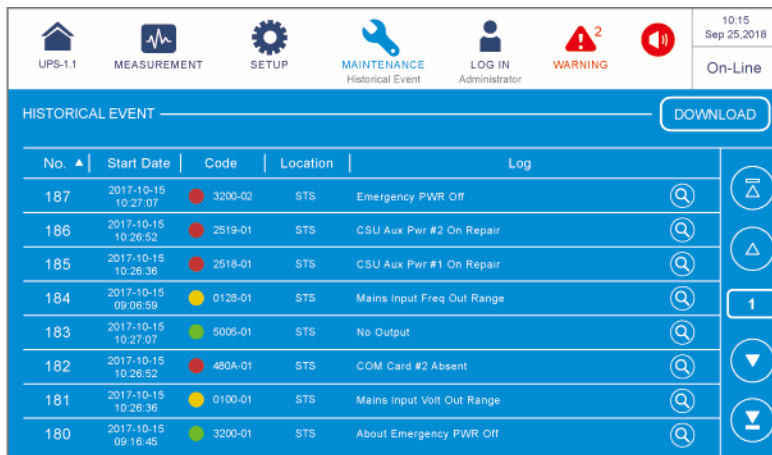

No.	Start Date	Code	Location	Log
187	2017-10-15 10:27:07	3200-02	STS	Emergency PWR Off
186	2017-10-15 10:26:52	2519-01	STS	CSU Aux Pwr #2 On Repair
185	2017-10-15 10:26:36	2518-01	STS	CSU Aux Pwr #1 On Repair
184	2017-10-15 09:06:59	0128-01	STS	Mains Input Freq Out Range
183	2017-10-15 10:27:07	5005-01	STS	No Output
182	2017-10-15 10:26:52	480A-01	STS	COM Card #2 Absent
181	2017-10-15 10:26:36	0100-01	STS	Mains Input Volt Out Range
180	2017-10-15 09:16:45	3200-01	STS	About Emergency PWR Off

7.7.3 Statistics

Path:  MAINTENANCE → Statistics

Item	Description
In Battery Mode	Shows how long and how many times the UPS runs in Battery mode.
In Bypass Mode	Shows how long and how many times the UPS runs in Bypass mode.
Operation Time	Means how long the UPS has operated.

To clear the statistics, please refer to **7.7.5 Clear**.

7.7.4 Test

Path:  MAINTENANCE → Test

You can perform a manual battery test via the LCD screen.

7.7.5 Clear

Path:  MAINTENANCE → Clear

Item	Description
Clear Statistics	After you select ' Clear ' and confirm clearance of statistics, all records of the statistics will be cleared.
Clear Historical Event	After you select ' Clear ' and confirm clearance of historical event logs, all historical event logs will be cleared.
Clear Battery Test Result	After you select ' Clear ' and confirm clearance of battery test result, the battery test result will be cleared.
Clear Kilowatt Hour (kWh)	After you select ' Clear ' and confirm clearance of kilowatt hour records, the kilowatt hour statistics will be cleared.



NOTE:

The records mentioned above are important information for system analysis and maintenance. Do not clear any of them without the consent of qualified service personnel.

7.7.6 Advanced Diagnosis

Path:  MAINTENANCE → **Advanced Diagnosis**

This is an optional function. If you would like to access this page, please contact Delta customer service.

7.7.7 Version & S/N



NOTE:

To operate the UPSs in parallel, please make sure all the versions below are the same between each parallel unit.

Path:  MAINTENANCE → **Version & S/N**

Item	Sub Item	Description
S/N	System	Check the system's serial no.
MAIN	Parallel Communication Card #_ MCU/ FPGA	Check and update the MCU or FPGA firmware version of a specific parallel communication card.
	System Control Card_ MCU/ FPGA	Check and update the MCU or FPGA firmware version of the system control card.
	Touch Panel _ MCU	Check and update the touch panel's MCU firmware version.
INV	PM #_ MCU/ FPGA	Check and update the MCU, MCU2 or FPGA firmware version of a specific power module's inverter.
PFC	PM #_ MCU/ MCU2	Check and update the MCU or MCU2 firmware version of a specific power module's PFC.
CHG	PM #_ MCU	Check and update the MCU version of a specific power module's CHG.

Chapter 8 : Optional Accessories

No.	Item	Function
1	Dust Filter	Prevents dust from entering into the UPS to ensure UPS reliability and to prolong product life.
2	Relay I/O Card	Increases the quantity of dry contacts.
3	EMS 1000 (EnviroProbe)	Monitors temperature, humidity and other connected monitoring devices in a room environment. Connect the EMS 1000 (Enviro-Probe) to the UPS's EMS port located at the rear of the touch panel, and the UPS will integrate the detected information from the EMS 1000 (EnviroProbe) and display relevant data on the LCD. See Figure 4-20 for the location of the EMS port. For details, please refer to 8.1 EMS Function on the LCD Screen .
4	Battery Cabinet Temperature Sensor Cable	Detects the temperature of an external battery cabinet connected to the UPS.
5	Parallel Cable (10-meter long)	Connects the parallel UPSs.
6	Parallel Cable (20-meter long)	Connects the parallel UPSs.
7	Battery Management System (BMS)	<p>If you use the lead-acid batteries, it is recommended to install the BMS to monitor (1) each battery's voltage, (2) each battery string's voltage and charging/ discharging current, and (3) battery environment temperature.</p> <p>The BMS should be connected to the UPS's BMS port located at the rear of the touch panel (see Figure 4-20). For details, please refer to 8.2 BMS Function on the LCD Screen and 7.6.4 Battery & Charging Setting.</p> <p> NOTE:</p> <p>The quantity of BMS to be installed depends on how many external battery cabinets (lead-acid batteries) are connected to the UPS. For BMS installation, please contact Delta customer service.</p>

No.	Item	Function
8	Multifunctional Communication Card (MFC)	<p>If you use the Delta lithium-ion batteries, you must purchase and install the multifunctional communication card (MFC) in the SMART slot shown in Figure 4-1 to monitor the battery status via the UPS's LCD. For relevant information, please refer to 8.3 MFC Function on the LCD Screen. Please contact Delta customer service if you need more information.</p> <p> NOTE: For parallel UPSs, please install one multifunctional communication card (MFC) in each parallel UPS if you use the Delta lithium-ion batteries.</p>



NOTE:

1. For details of installation and operation of the accessories mentioned above, please refer to the **Quick Guide, User Guide, or Installation & Operation Guide** included in the package of the relevant optional accessory.
2. If you want to purchase any accessories mentioned above, please contact your local dealer or customer service.

8.1 EMS Function on the LCD Screen

- **Path 1:** Tap the shortcut button  on the **Main Screen**.

Path 2:  → **EMS**

To activate the EMS function, you have to connect the optional EMS 1000 (EnviroProbe) device with the UPS and perform the EMS settings via the LCD. After that, the EMS information of each device (ID #) will be displayed on the **EMS** screen.



NOTE:

1. The **EMS** screen display is related to the settings in the  → **EMS Setting**; the settings can be adjusted according to your needs.
2. For installation of the optional EMS 1000 (EnviroProbe), please refer to the instructions below and the **EnviroProbe 1000 Quick Guide** attached in the package of the optional EMS 1000 (EnviroProbe).

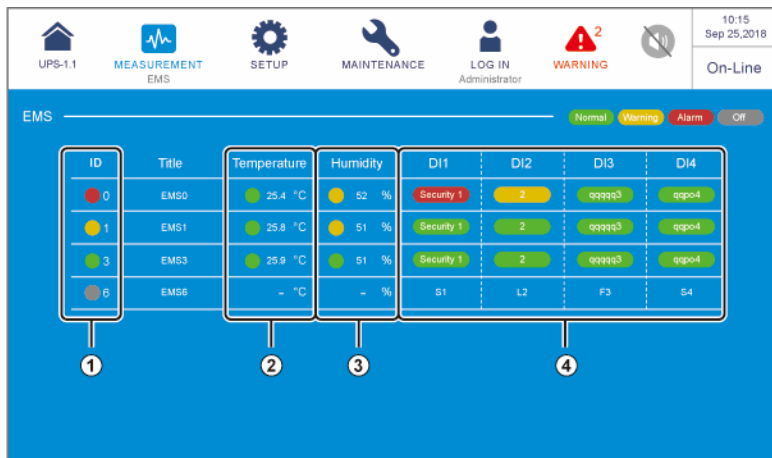

No.	Item	Color (Status)	Descriptions
1	ID	Green (Normal) Yellow (Warning) Red (Alarm) Gray (Off)	<ol style="list-style-type: none"> 1. Different ID # represents a different EMS 1000 (EnviroProbe) device. <p> NOTE: The LCD will only show the EMS 1000 (EnviroProbe) devices (ID #) whose status have been set as 'Enable'.</p> <ol style="list-style-type: none"> 2. Shows the integrated status of each EMS 1000 (EnviroProbe) device. The integrated status is determined by the most severe status among the device's Temperature (°C) status, Humidity (%) status, and the status of input contacts DI1 ~ DI4.

No.	Item	Color (Status)	Descriptions
2	Temperature	Green (Normal) Yellow (Warning) Red (Alarm)	<p>The color represents the status of Temperature/ Humidity based on the EMS settings.</p> <p>When the detected Temperature/ Humidity</p> <ol style="list-style-type: none"> 1. is lower than the value set for Warning, it shows Green (Normal). 2. is higher than the value set for Warning but lower than the value set for Alarm, it shows Yellow (Warning). 3. is higher than the value set for Alarm, it shows Red (Alarm). 4. has reached the value set for Alarm/ Warning, the status will recover from Alarm to Warning/ from Warning to Normal respectively only when the detected value has been lowered to its corresponding Recovery value.
3	Humidity	Green (Normal) Yellow (Warning) Red (Alarm)	
4	DI1	Green (None/ Information) Yellow (Warning) Red (Alarm)	<ol style="list-style-type: none"> 1. Different colors represent different status that the input contact has detected. 2. The Title, NO/ NC, and Event Type of the input contact can be adjusted according to your needs.
	DI2		
	DI3		
	DI4		

● **Connecting the Optional EMS 1000 (EnviroProbe)**

1. You can connect a maximum of 16 optional EMS 1000 (EnviroProbe) devices to each UPS to expand the environment monitoring range. A maximum of 8 UPS units can be paralleled. Please use a CAT-5 cable (user-supplied & the cable length depends on the on-site application and environment) to connect the EMS 1000 (EnviroProbe) to the EMS port on the UPS. For the location of the EMS port, please refer to **4.2 Communication Interfaces II: at the Rear of the Touch Panel**.
2. The UPS only supports RS485 communication. When installing the EMS 1000 (EnviroProbe), please set the device's communication mode as RS485 following **3-1 Comm DIP Switch Settings** of the **EnviroProbe 1000 Quick Guide**.
3. When installing the EMS 1000 (EnviroProbe), please set the ID # by the four ID DIP switches on the left of the device following **3-2 ID DIP Switch Settings of the EnviroProbe 1000 Quick Guide**.



NOTE:

1. The ID # of each EMS 1000 (EnviroProbe) device connected to the UPS must be different so that the UPS can identify each device.

4. To enable the EMS function, you have to set up relevant items on the LCD after connecting the optional EMS 1000 (EnviroProbe) to the UPS.

- Path:  → **EMS Setting (Administrator login required)**

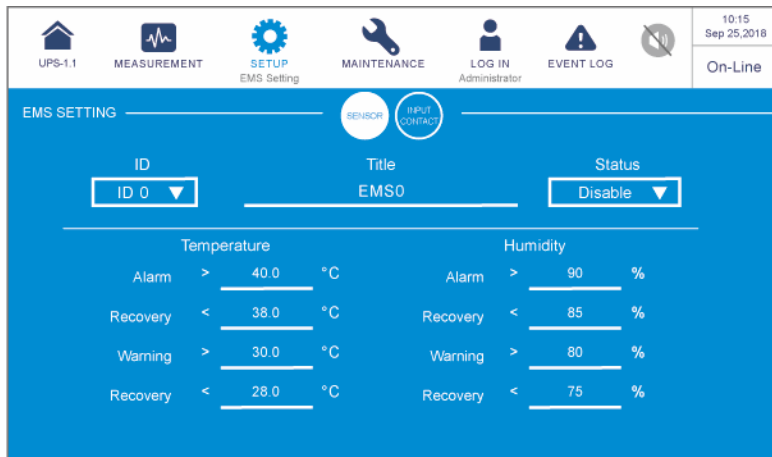

The screenshot shows the 'EMS SETTING' screen with the following configuration:

ID	Title	Status
ID 0	EMS0	Disable

Temperature		Humidity	
Alarm	> 40.0 °C	Alarm	> 90 %
Recovery	< 38.0 °C	Recovery	< 85 %
Warning	> 30.0 °C	Warning	> 80 %
Recovery	< 28.0 °C	Recovery	< 75 %

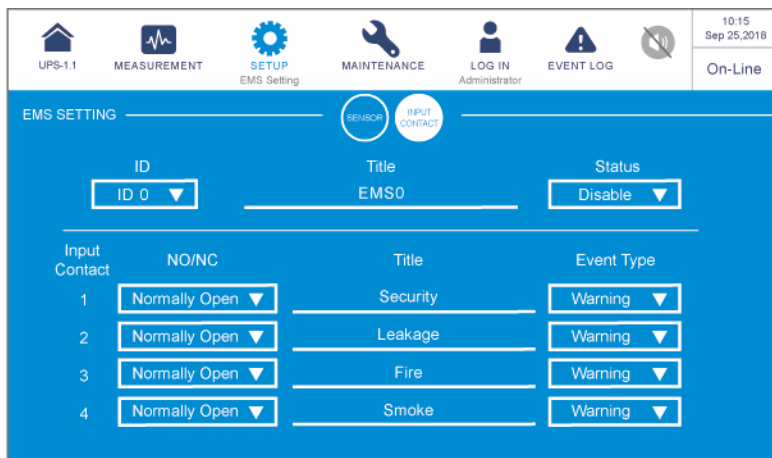

The screenshot shows the 'EMS SETTING' screen with the following configuration:

Input Contact	NO/NC	Title	Event Type
1	Normally Open	Security	Warning
2	Normally Open	Leakage	Warning
3	Normally Open	Fire	Warning
4	Normally Open	Smoke	Warning



NOTE:

The default values are shown in the figures above.

Item	Sub Item	Description
SENSOR	ID	<p>Set the ID # (ID 0/ ID 1/ .../ ID 15) according to the ID DIP switch setting of the EMS 1000 (EnviroProbe) device.</p>  <p>NOTE: If the ID # setting is wrong, the warning message 'The EMS 1000 ID # Communication Fail' will appear.</p>
	Title	Set the title for the EMS 1000 (EnviroProbe), 16 characters at most.
	Status	The status ' Enable/ Disable ' determines whether or not the LCD shows the EMS information of the EMS 1000 (EnviroProbe) device (ID #).
	Temperature	Set the temperature (°C) values for Alarm/ Warning/ Recovery.
	Humidity	Set the Humidity (%) values for Alarm/ Warning/ Recovery.
INPUT CONTACT	Input Contact 1	<ol style="list-style-type: none"> Set the input contact as Normally Open (NO)/ Normally Closed (NC). Set the Title for the input contact, 16 characters at most. Set the Event Type as None/ Information/ Warning/ Alarm.
	Input Contact 2	
	Input Contact 3	
	Input Contact 4	

8.2 BMS Function on the LCD Screen

- Path:  → **BMS**

To activate the BMS function, you have to connect the optional battery management system (BMS) with the UPS and perform the BMS settings via the LCD. After that, you can check **String Voltage**, **String Current**, **Ambient Temperature**^{*1}, **Cell Volt.** (Voltage) and **Cell IR.**^{*2} (Internal Resistance) of the **Main Module** and of each **Ext #n Module**.



NOTE:

1. ^{*1} means that the item will only show up after you select 'Main' in the select-module list in the upper left corner of the screen.
2. ^{*2} means that the item will only show up after you go to  → **BMS Setting** and select 'Internal Resistance' in the **Module Type** list.

Tap the icon , and you can view the **Internal Resistance Alarm Threshold**.

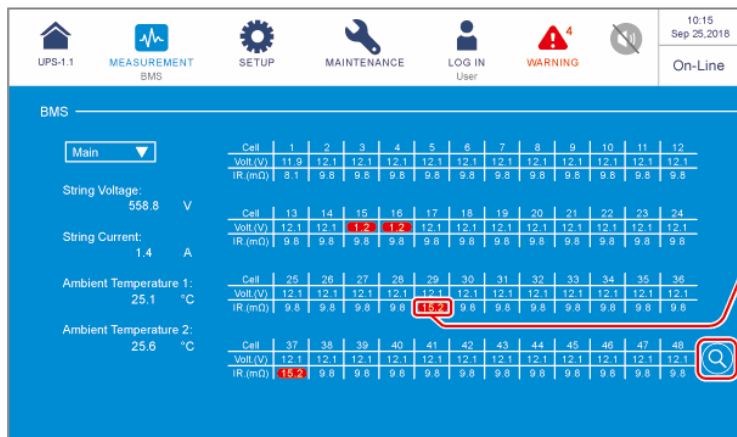

When the Cell IR. Value Exceeds the Internal Resistance Alarm Threshold Value, the Column Will Show the Warning in Red.

Tap View the Internal Resistance Alarm Threshold Values.

- Path:  → **BMS Setting (Administrator login required)**

After entering the **BMS SETTING** screen, you can view the **Alarm Threshold Values (High & Low)**^{*1} values of **Cell Voltage**, **String Voltage** and **Ambient Temperature**^{*2}.

You can also set up the following items. These settings must be carried out by qualified service personnel. Please contact Delta customer service for assistance.



NOTE:

1. ^{*1} The **Alarm Threshold Values (High & Low)** are defined by the service personnel during the installation process of the optional battery management system (BMS).
2. ^{*2} The item will only show up after you select 'Main' in the **Module** list.

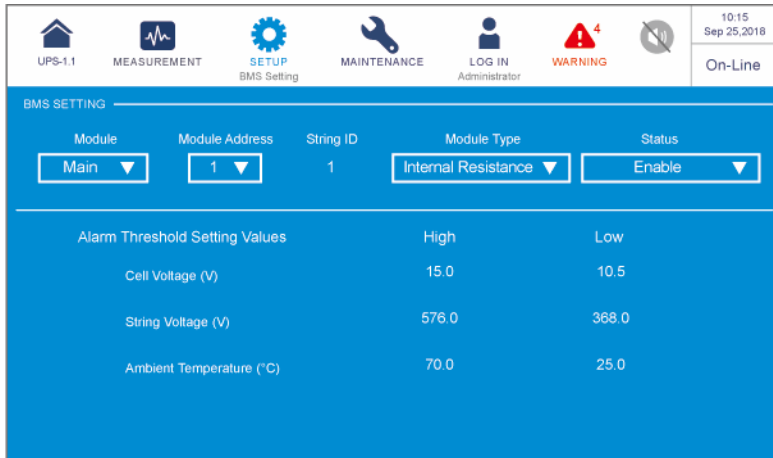

Item	Description
Module	Select Main/ Ext #n module.
Module Address	Set the module address.
Module Type	Set the module type as Voltage Type/ Internal Resistance.
Status	The status ' Enable/ Disable ' determines whether or not the LCD shows the BMS information of the optional battery management system (BMS).

8.3 MFC Function on the LCD Screen

The **PAGE 3 & MFC** screens (see the figures below) will only appear on the LCD if you use the Delta lithium-ion batteries with the optional multifunctional communication (MFC) card being installed in the SMART slot. Please contact Delta customer service if you need more information.

- **Path:**  → **Battery Status**

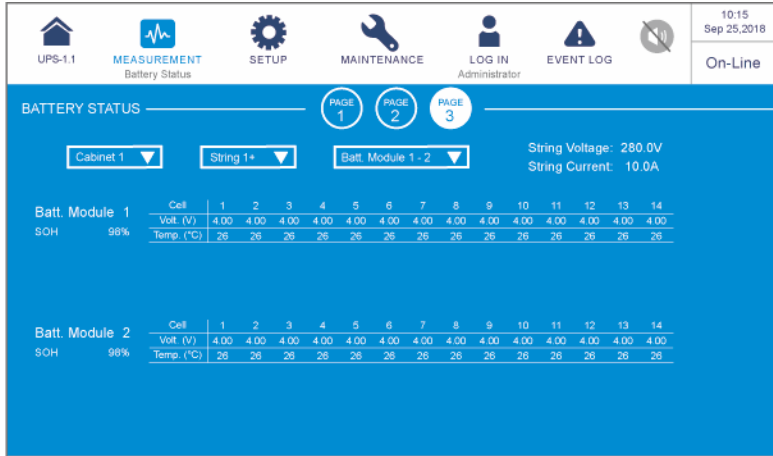

In the screen, you can use the three drop-down lists in the upper left corner to choose the **Cabinet**, **String**, and **Battery Module** to view the corresponding **String Voltage**, **String Current**, battery module's **SOH** (State of Health) and the battery cell's **Voltage** and **Temperature**.

- **Path:**  → **General Setting (Administrator login required)**

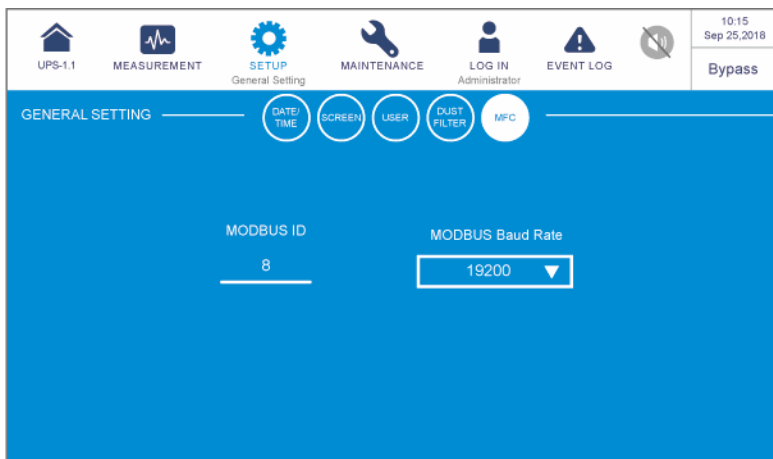

Item	Sub Item	Description
MFC (Multifunctional Communication Card)	MODBUS ID	Set up the MODBUS ID for the optional multifunctional communication card (MFC).
	MODBUS Baud Rate	Set up the MODBUS baud rate for the optional multifunctional communication card (MFC).

- Path:  MAINTENANCE → Version & S/N

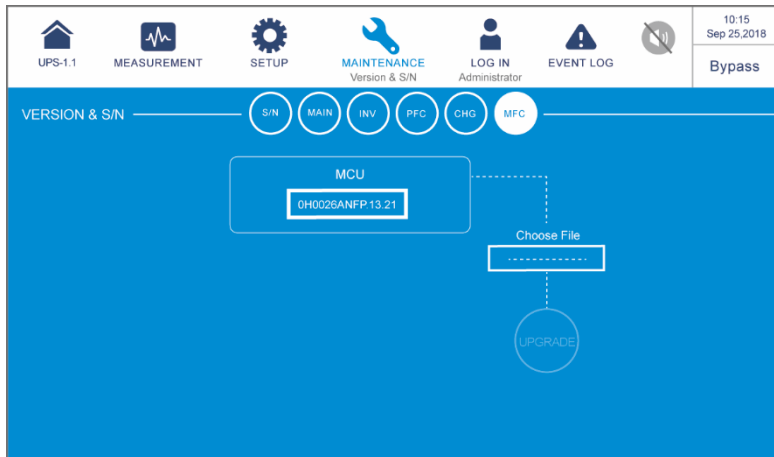

Item	Sub Item	Description
MFC (Multifunctional Communication Card)	MCU	Check and update the MCU firmware version of the optional multifunctional communication card (MFC).

Chapter 9 : Maintenance

- **UPS**

1. UPS Cleaning:

Regularly clean the UPS, especially the slits, openings and filters, to ensure that the air freely flows into the UPS to avoid overheating. If necessary, use an air blower to clean the slits and openings and replace the filters regularly to prevent any object from blocking or covering these areas.

2. UPS Regular Inspection:

- a. Monthly check the filters and regularly replace them.
- b. Regularly check the UPS every half year and inspect:
 - 1) Whether the UPS and its LED indicators and alarm operate normally.
 - 2) Whether the UPS works in Bypass mode (normally, the UPS works in normal mode). If yes, check if any error, overload, internal fault, etc. occurs.
 - 3) Whether the battery voltage is normal. If the battery voltage is too high or too low, find the root cause.

- **Batteries**

The DPS series UPS uses the lead-acid batteries or the lithium-ion batteries. Make sure to replace the batteries according to battery life. However, the actual battery life depends on the environment temperature, usage, and charging/ discharging frequency. High temperature environments and high charging/ discharging frequency will quickly shorten battery life. Please follow the suggestions below to ensure normal battery life.

1. Keep usage temperature between 15°C ~ 25°C (59°F ~ 77°F).
2. When the UPS needs to be stored for an extended period of time, the lead-acid batteries must be recharged once every three months and the charging time must not be less than 24 hours each time. As for the lithium-ion batteries, please contact your battery supplier for the charging frequency and charging duration.

- **Fans**

Higher temperatures shorten fan life. When the UPS is running, please check if all of the fans work normally and make sure there is good ventilation around and through the UPS. If not, replace the fans.



NOTE:

Please ask your local dealer or customer service for more maintenance information. Do not perform maintenance if you are not trained for it.

Appendix 1 : Technical Specifications

Model		DPS			
UPS Capacity		300kVA/ 300kW	400kVA/ 400kW	500kVA/ 500kW	600kVA/ 600kW
Input	Nominal Voltage	220/380 Vac, 230/400 Vac, 240/415 Vac (3Φ4W + G)			
	Voltage Range	176 ~ 276 Vac*1 (full load)			
	Current Harmonic Distortion	≤ 3%*2			
	Power Factor	> 0.99			
	Frequency Range	40 ~ 70 Hz			
Output	Voltage	220/380 Vac, 230/400 Vac, 240/415 Vac (3Φ4W + G)			
	Voltage Harmonic Distortion	≤ 1.5% (linear load)			
	Frequency	50/60 Hz			
	Overload Capability	≤ 110%: 60 minutes*3; ≤ 125%: 10 minutes; ≤ 150%: 1 minute			
Display		10" Touch Panel			
Interface	Standard	External battery temperature dry contact × 4, External switch/ breaker status dry contact × 4, Output dry contact × 6, Input dry contact × 4, Parallel port × 4, USB type A × 2, USB type B × 1, RS-232 port × 1, MODBUS port × 1, BMS (RJ45) × 1, Ethernet × 1, SMART slot × 1, REPO × 1			
Efficiency	Online Mode	up to 96.50%			
	ECO Mode	99%			
Battery	Nominal Voltage	± 240 Vdc (Default)			
	Charge Voltage	± 272 Vdc (adjustable from 204 Vdc to 312 Vdc)			

Model		DPS			
UPS Capacity		300kVA/ 300kW	400kVA/ 400kW	500kVA/ 500kW	600kVA/ 600kW
	Protection of Battery Deep Discharge	Yes			
Environment	Operating Altitude	1000 meters (without derating) 3280 ft (without derating)			
	Operating Temperature	0 ~ 40°C (32 ~ 104°F)			
	Relative Humidity	95% (non-condensing)			
	Audible Noise	< 80 dBA*4			
		1 meter (3.28 ft) in front of the UPS			
IP Degree of Protection	IP 20				
Others	Parallel Redundancy	Yes (up to 8 units)			
	Emergency Power Off	Yes			
	Battery-start	Yes			
Physical	Dimensions (W × D × H)	600 × 900 × 2000 mm	1200 × 900 × 2000 mm		
		23.6" × 35.4" × 78.7"	47.2" × 35.4" × 78.7"		
	Weight	515 kg	700 kg	811 kg	970 kg
		1135 lb	1543 lb	1787 lb	2138 lb



NOTE:

1. *1: With a load capacity of 70%, the input voltage range will be 132/228 ~ 276/478 Vac.
2. *2: When input vTHD is < 1%.
3. *3: When the environment temperature is below 30°C (86°F).
4. *4: Conditional.
5. Please refer to the rating label for the safety rating.
6. All specifications are subject to change without prior notice.

Appendix 2 : Warranty

Seller warrants this product, if used in accordance with all applicable instructions, to be free from original defects in material and workmanship within the warranty period. If the product has any failure problem within the warranty period, Seller will repair or replace the product at its sole discretion according to the failure situation.

This warranty does not apply to normal wear or to damage resulting from improper installation, operation, usage, maintenance or irresistible force (i.e. war, fire, natural disaster, etc.), and this warranty also expressly excludes all incidental and consequential damages.

Maintenance service for a fee is provided for any damage out of the warranty period. If any maintenance is required, please directly contact the supplier or Seller.



WARNING:

The individual user should take care to determine prior to use whether the environment and the load characteristic are suitable, adequate or safe for the installation and the usage of this product. The User Manual must be carefully followed. Seller makes no representation or warranty as to the suitability or fitness of this product for any specific application.

No. : 5013 27580101

Version : V 1.1

Release Date : 2020_4_7

- Global Headquarter

Taiwan

Delta Electronics Inc.
39 Section 2, Huandong Road, Shanhua District,
Tainan City 74144, Taiwan
T +886 6 505 6565
E ups.taiwan@deltaww.com

- Regional Office

The United States

Delta Electronics (Americas) Ltd.
46101 Fremont Blvd. Fremont, CA 94538
T +1 510 344 2157
E ups.na@deltaww.com

Australia

Delta Energy Systems Australia Pty Ltd.
Unit 20-21, 45 Normanby Road, Notting Hill VIC 3168, Australia
T +61 3 9543 3720
E ups.australia@deltaww.com

South America

Delta Greentech (Brasil) S/A
Rua Itapeva, 26 - 3º andar Edifício Itapeva One - Bela Vista
01332-000 - São Paulo - SP - Brazil
T +55 11 3568 3850
E ups.brazil@deltaww.com

Thailand

Delta Electronics (Thailand) Public Co.,Ltd.
909 Soi 9, Moo 4, E.P.Z., Bangpoo Industrial Estate, Tambon Prakasa,
Amphur Muang-samutprakarn, Samutprakarn Province 10280, Thailand
T +662 709-2800
E ups.thailand@deltaww.com

China

Delta GreenTech (China) Co., Ltd.
238 Minxia Road, Pudong, Shanghai, 201209 P.R.C
T +86 21 5863 5678
+86 21 5863 9595
E ups.china@deltaww.com

South Korea

Delta Electronics (Korea), Inc.
1511, Byucksan Digital Valley 6-cha, Gasan-dong, Geumcheon-gu,
Seoul, Korea, 153-704
T +82-2-515-5303
E ups.south.korea@deltaww.com

Singapore

Delta Electronics Int'l (Singapore) Pte Ltd.
4 Kaki Bukit Ave 1, #05-04, Singapore 417939
T +65 6747 5155
E ups.singapore@deltaww.com

India

Delta Power Solutions (India) Pvt. Ltd.
Plot No. 43, Sector-35, HSIIDC, Gurgaon-122001, Haryana, India
T +91 124 4874 900
E ups.india@deltaww.com

EMEA

Delta Electronics (Netherlands) BV
Zandsteen 15, 2132MZ Hoofddorp, The Netherlands
T +31 20 655 09 00
E ups.netherlands@deltaww.com



5013275801