

# DELPHI SERIES



## E48SP12020 Eighth Brick DC/DC Power Module 36~75V in, 12V/20A out, 240W

E48SP12020, 36~75V input, Eighth Brick, single output, isolated DC/DC converters are the latest offering from a world leader in power systems technology and manufacturing — Delta Electronics, Inc. The E48SP product provides up to 240 watts of power in an industry standard footprint and pinout. The E48SP12020 converter operates from an input voltage of 36V to 75V. Efficiency is 94.5% for the 12V output at full load. With creative design technology and optimization of component placement, these converters possess outstanding electrical and thermal performance, as well as extremely high reliability under highly stressful operating conditions. All models are fully protected from abnormal input/output voltage, current, and temperature conditions. The Delphi Series converters meet all safety requirements with basic insulation.

## FEATURES

- ◆ High efficiency: 94.5% @12V/20A
- ◆ Size:
  - 58.4mm x 22.8mm x 10.1mm (2.30"x0.90"x0.40") W/O Heat spreader
  - 58.4mm x 22.8mm x 12.2mm (2.30"x0.90"x0.48") With Heat spreader
- ◆ Industry standard pin out
- ◆ Fixed frequency operation
- ◆ Input UVLO, Output OCP & OVP, OTP
- ◆ Monotonic startup into normal and Pre-biased loads
- ◆ 2250V Isolation and basic insulation
- ◆ No minimum load required
- ◆ No negative current during power on or power off;
- ◆ ISO 9001, TL 9000, ISO 14001, QS 9000, OHSAS 18001 certified manufacturing facility
- ◆ IEC/EN/UL/CSA 62368-1, 2nd edition
- ◆ IEC/EN/UL/CSA 60950-1, 2nd edition+A2

## OPTIONS

- ◆ Positive On/Off logic
- ◆ Short pin lengths available
- ◆ Latched over voltage protection

## Soldering Methods

- ◆ Wave soldering
- ◆ Hand soldering
- ◆ Reflow soldering (MSL rating of 3)

## APPLICATIONS

- ◆ Telecom/Datacom
- ◆ Wireless Networks
- ◆ Optical Network Equipment
- ◆ Server and Data Storage
- ◆ Industrial/Test Equipment

DATASHEET

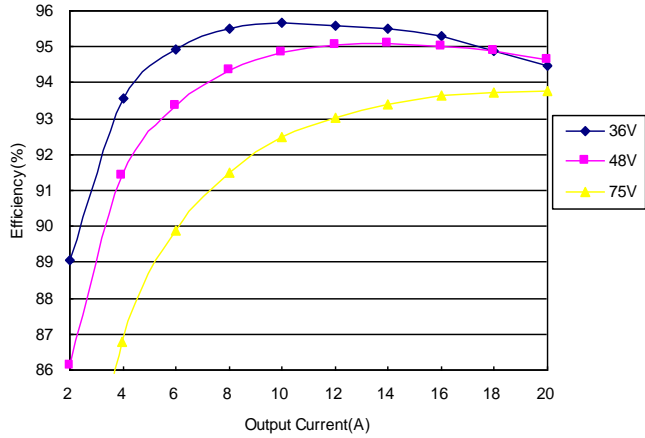
DS\_E48SP12020\_06012020

# TECHNICAL SPECIFICATIONS

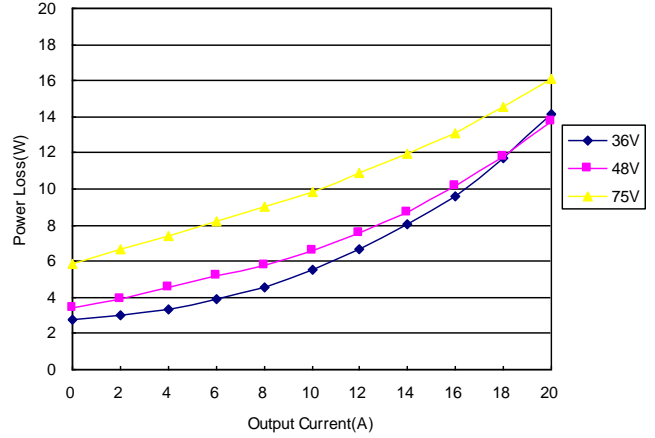
(T<sub>A</sub>=25°C, airflow rate=300 LFM, V<sub>in</sub>=48Vdc, nominal V<sub>out</sub> unless otherwise noted.)

PARAMETER	NOTES and CONDITIONS	E48SP12020 (Standard)			
		Min.	Typ.	Max.	Units
<b>ABSOLUTE MAXIMUM RATINGS</b>					
Input Voltage					
Continuous				80	Vdc
Transient (100ms)	100ms			100	Vdc
Operating Hot Spot Temperature (Without heat spreader)	Refer to figure 18 for measuring point	-40		122	°C
Operating Case Temperature (With heat spreader)	Refer to figure 20 for measuring point	-40		110	°C
Storage Temperature		-55		125	°C
Input/Output Isolation Voltage				2250	Vdc
<b>INPUT CHARACTERISTICS</b>					
Operating Input Voltage					
		36		75	Vdc
Input Under-Voltage Lockout					
Turn-On Voltage Threshold		32.5	34	35.5	Vdc
Turn-Off Voltage Threshold		30.5	32	33.5	Vdc
Lockout Hysteresis Voltage		1	2	3	Vdc
Maximum Input Current	V <sub>in</sub> =36V, 100% Load,		7	7.8	A
No-Load Input Current			70	150	mA
Off Converter Input Current			8	13	mA
Inrush Current(I <sup>2</sup> t)	With 100µF external input capacitor			1	A <sup>2</sup> s
Start up Current	Peak, V <sub>in</sub> =36V, 100% Load, With 5000µF Co		7	12	A
Input Terminal Ripple Current	RMS, V <sub>in</sub> =48V, With 100µF input cap.		0.16	0.24	A
Input Reflected-Ripple Current	P-P thru 12µH inductor, 5Hz to 20MHz		6		mA
Input Voltage Ripple Rejection	120 Hz		60		dB
<b>OUTPUT CHARACTERISTICS</b>					
Output Voltage Set Point					
	V <sub>in</sub> =48V, I <sub>o</sub> =I <sub>o,max</sub> , T <sub>c</sub> =25°C	11.67	11.85	12.02	Vdc
Output Voltage Regulation					
Over Load	I <sub>o</sub> =I <sub>o,min</sub> to I <sub>o,max</sub>			+20	mV
Over Line	V <sub>in</sub> =36V to 75V			±15	mV
Over Temperature	T <sub>c</sub> =-40°C to 125°C		±120		mV
Total Output Voltage Range	over sample load, and temperature	11.5	11.85	12.2	V
Output Voltage Ripple and Noise					
Peak-to-Peak	5Hz to 20MHz bandwidth				
RMS	Full Load, 1µF ceramic, 10µF tantalum		100	200	mV
Operating Output Current Range	Full Load, 1µF ceramic, 10µF tantalum		40	80	mV
Output DC Current-Limit Inception	Full input voltage range	0		20	A
Output Voltage 10% Low	Output Voltage 10% Low	110		150	%
<b>DYNAMIC CHARACTERISTICS</b>					
Output Voltage Current Transient					
	48V, 10µF Tan & 1µF Ceramic load cap, 0.1A/µs				
Positive Step Change in Output Current	50% I <sub>o,max</sub> to 75% I <sub>o,max</sub>		200	400	mV
Negative Step Change in Output Current	75% I <sub>o,max</sub> to 50% I <sub>o,max</sub>		200	400	mV
Setting Time (within 1% V <sub>out</sub> nominal)				200	µs
Turn-On Transient					
Start-Up Time, From On/Off Control			30	40	ms
Start-Up Time, From Input			30	40	ms
Maximum Output Capacitance	Full load; no overshoot of V <sub>out</sub> at startup			5000	µF
<b>EFFICIENCY</b>					
100% Load	V <sub>in</sub> =48V	93.5	94.5		%
60% Load	V <sub>in</sub> =48V	94	95		%
<b>ISOLATION CHARACTERISTICS</b>					
Input to Output					
Isolation Resistance		10			MΩ
Isolation Capacitance			1500		pF
<b>FEATURE CHARACTERISTICS</b>					
Switching Frequency					
			245		kHz
ON/OFF Control, Negative Remote On/Off logic					
Logic Low (Module On)	V <sub>on/off</sub>	-0.7		0.8	V
Logic High (Module Off)	V <sub>on/off</sub>	2.4		50	V
ON/OFF Control, Positive Remote On/Off logic					
Logic Low (Module Off)	V <sub>on/off</sub>	-0.7		0.8	V
Logic High (Module On)	V <sub>on/off</sub>	2.4		50	V
ON/OFF Current (for both remote on/off logic)	I <sub>on/off</sub> at V <sub>on/off</sub> =0.0V			0.5	mA
ON/OFF Current (for both remote on/off logic)	I <sub>on/off</sub> at V <sub>on/off</sub> =2.4V	10			µA
Leakage Current (for both remote on/off logic)	Logic High, V <sub>on/off</sub> =15V			50	µA
Output Over-Voltage Protection	Over full temp range; % of nominal V <sub>out</sub>	14.6		18	V
<b>GENERAL SPECIFICATIONS</b>					
MTBF	I <sub>o</sub> =100% of I <sub>o,max</sub> ; 300LFM; T <sub>a</sub> =25°C		1.19		M hours
Weight	Open frame		29.1		grams
Weight	With heat spreader		39.2		grams
Over-Temperature Shutdown (Without heat spreader)	Refer to figure 18 for measuring point		132		°C
Over-Temperature Shutdown (With heat spreader)	Refer to figure 20 for measuring point		120		°C

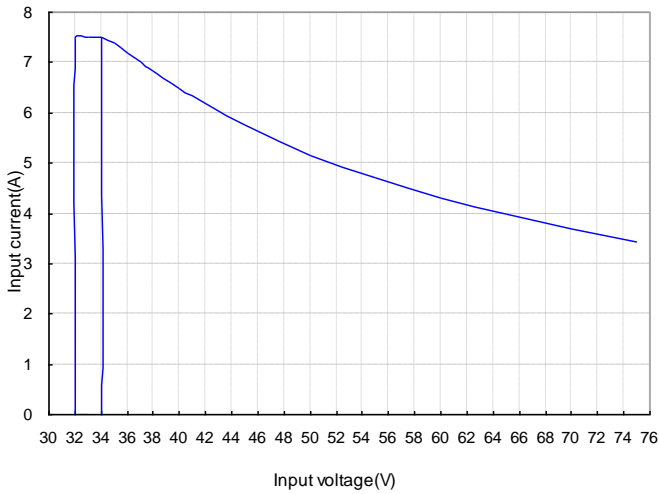
# ELECTRICAL CHARACTERISTICS CURVES



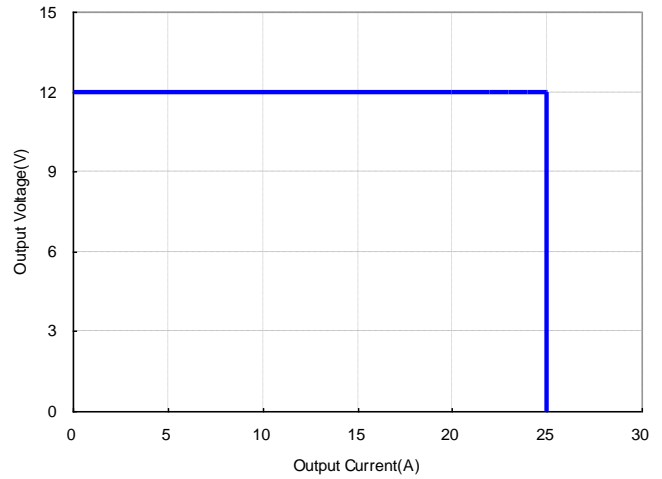
**Figure 1:** Efficiency vs. load current for minimum, nominal, and maximum input voltage at 25°C



**Figure 2:** Power dissipation vs. load current for minimum, nominal, and maximum input voltage at 25°C



**Figure 3:** Typical full load input characteristics at room temperature

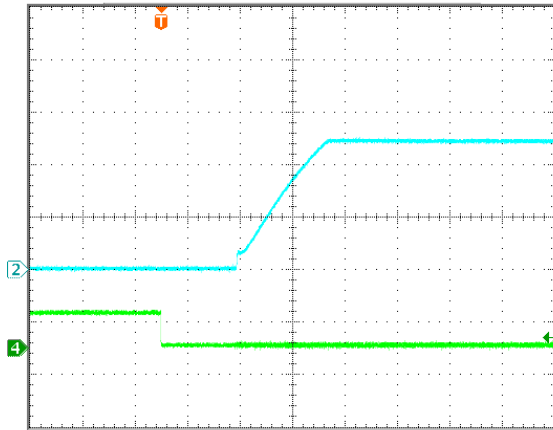


**Figure 4:** Output voltage regulation vs load current showing typical current limit curves and converter shutdown points for minimum, nominal, and maximum input voltage at room temperature

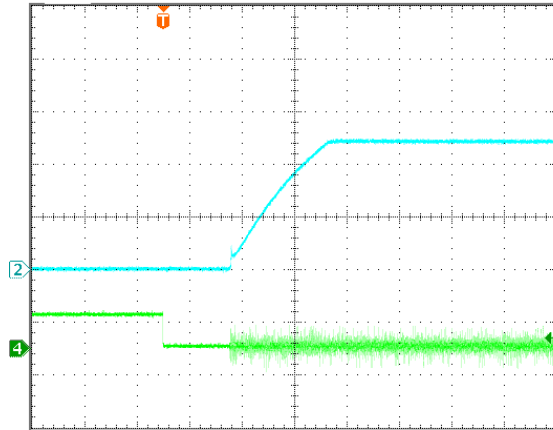


## ELECTRICAL CHARACTERISTICS CURVES

### For Negative Remote On/Off Logic

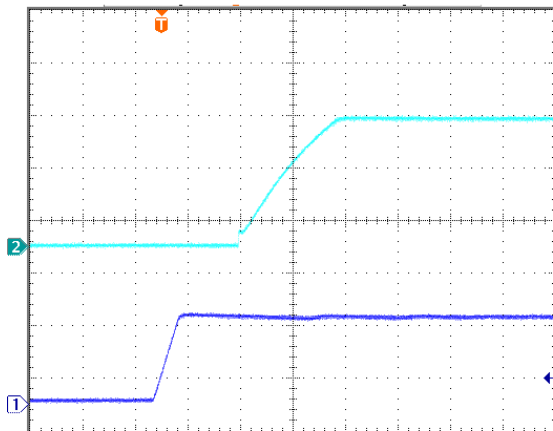


**Figure 5:** Turn-on transient at zero load current (10ms/div).  $V_{in}=48V$ . Top Trace:  $V_{out}$ , 5V/div; Bottom Trace: ON/OFF input, 5V/div

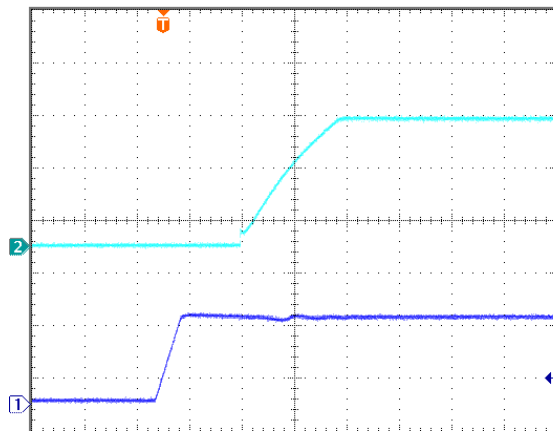


**Figure 6:** Turn-on transient at full rated load current (constant current load) (10 ms/div).  $V_{in}=48V$ . Top Trace:  $V_{out}$ , 5V/div; Bottom Trace: ON/OFF input, 5V/div

### For Input Voltage Start up

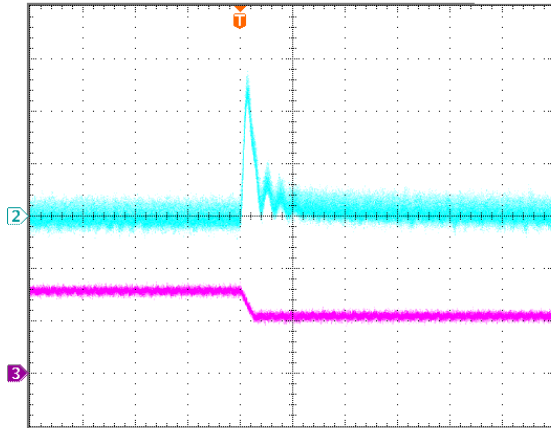


**Figure 7:** Turn-on transient at zero load current (10 ms/div).  $V_{in}=48V$ . Top Trace:  $V_{out}$ , 5V/div, Bottom Trace: input voltage, 30V/div

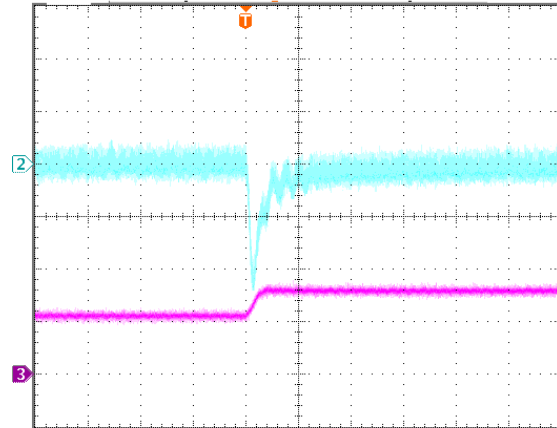


**Figure 8:** Turn-on transient at full rated load current (constant current load) (10 ms/div).  $V_{in}=48V$ . Top Trace:  $V_{out}$ , 5V/div; Bottom Trace: input voltage, 30V/div

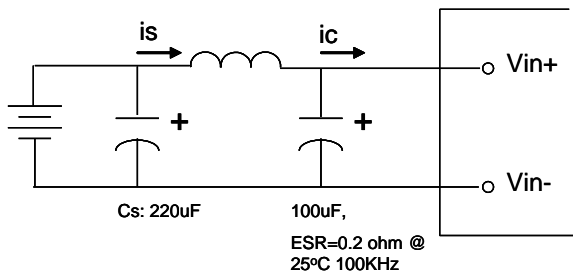
## ELECTRICAL CHARACTERISTICS CURVES



**Figure 9:** Output voltage response to step-change in load current (75%-50% of  $I_o$ , max;  $di/dt = 0.1A/\mu s$ ,  $V_{in}=48V$ ). Load cap:  $10\mu F$ , tantalum capacitor and  $1\mu F$  ceramic capacitor. Top Trace:  $V_{out}$  (80mV/div, 200us/div); Bottom Trace:  $I_o$  (10A/div, 200us/div). Scope measurement should be made using a BNC cable (length shorter than 20 inches). Position the load between 51 mm to 76 mm (2 inches to 3 inches) from the module.

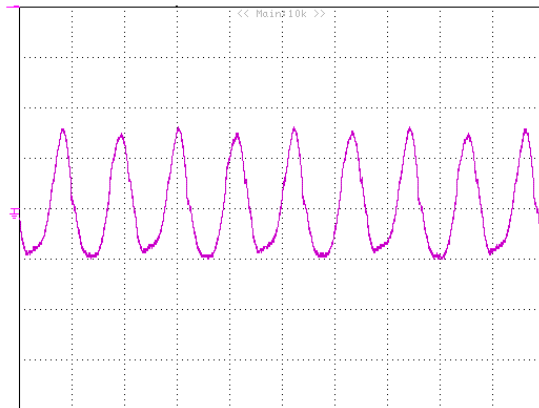


**Figure 10:** Output voltage response to step-change in load current (50%-75% of  $I_o$ , max;  $di/dt = 0.1A/\mu s$ ,  $V_{in}=48V$ ). Load cap:  $10\mu F$ , tantalum capacitor and  $1\mu F$  ceramic capacitor. Top Trace:  $V_{out}$  (80mV/div, 200us/div); Bottom Trace:  $I_o$  (10A/div, 200us/div). Scope measurement should be made using a BNC cable (length shorter than 20 inches). Position the load between 51 mm to 76 mm (2 inches to 3 inches) from the module.



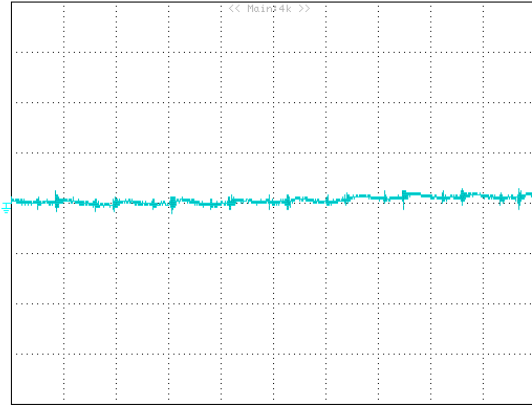
**Figure 11:** Test set-up diagram showing measurement points for Input Terminal Ripple Current and Input Reflected Ripple Current.

Note: Measured input reflected-ripple current with a simulated source Inductance ( $L_{TEST}$ ) of  $12\mu H$ . Capacitor  $C_s$  offset possible battery impedance. Measure current as shown below

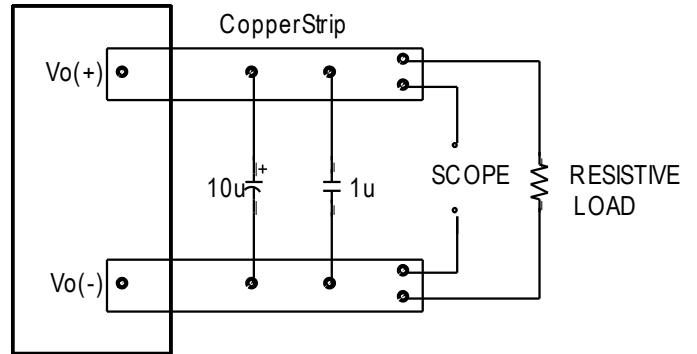


**Figure 12:** Input Terminal Ripple Current,  $i_c$ , at full rated output current and nominal input voltage with  $12\mu H$  source impedance and  $100\mu F$  electrolytic capacitor (200 mA/div, 2us/div).

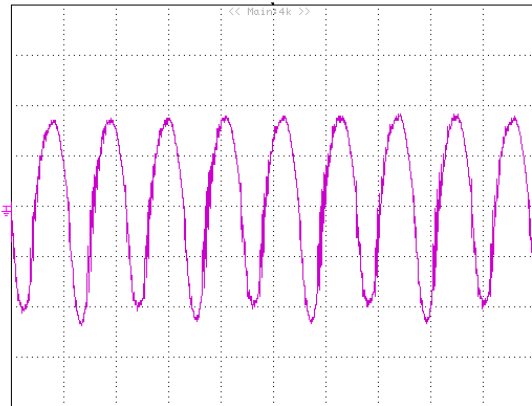
## ELECTRICAL CHARACTERISTICS CURVES



**Figure 13:** Input reflected ripple current,  $i_s$ , through a  $12\mu\text{H}$  source inductor at nominal input voltage and rated load current ( $20\text{ mA/div}$ ,  $2\mu\text{s/div}$ ).



**Figure 14:** Output voltage noise and ripple measurement test setup



**Figure 15:** Output voltage ripple at nominal input voltage and rated load current ( $I_o=20\text{A}$ ) ( $20\text{ mV/div}$ ,  $2\mu\text{s/div}$ )  
Load capacitance:  $1\mu\text{F}$  ceramic capacitor and  $10\mu\text{F}$  tantalum capacitor. Bandwidth:  $20\text{ MHz}$ . Scope measurements should be made using a BNC cable (length shorter than  $20$  inches). Position the load between  $51\text{ mm}$  to  $76\text{ mm}$  ( $2$  inches to  $3$  inches) from the module.

## DESIGN CONSIDERATIONS

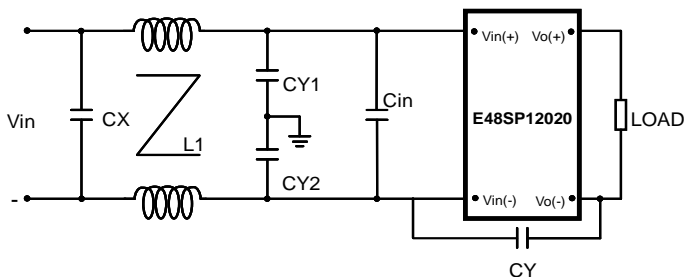
### Input Source Impedance

The impedance of the input source connecting to the DC/DC power modules will interact with the modules and affect the stability. A low ac-impedance input source is recommended. If the source inductance is more than a few  $\mu\text{H}$ , we advise adding a 33 to 100  $\mu\text{F}$  electrolytic capacitor (ESR < 0.7  $\Omega$  at 100 kHz) mounted close to the input of the module to improve the stability.

### Layout and EMC Considerations

Delta's DC/DC power modules are designed to operate in a wide variety of systems and applications. For design assistance with EMC compliance and related PWB layout issues, please contact Delta's technical support team. An external input filter module is available for easier EMC compliance design. Below is the reference design for an input filter tested with E48SP12020XXXX to meet class B in CISPR 22.

### Schematic and Components List



Cin is 100 $\mu\text{F}$ \*2 low ESR Aluminum cap;

CX is 2.2 $\mu\text{F}$  ceramic cap;

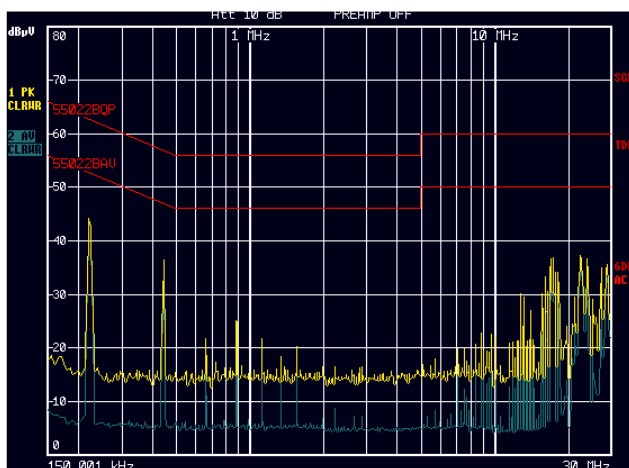
CY1 are 10nF ceramic caps;

CY2 are 10nF ceramic caps;

CY is 1nF ceramic cap;

L1 is common-mode inductor, L1=0.53mH;

**Test Result:** Vin=48V, Io=20A,



Yellow line is quasi peak mode; Blue line is average mode.

### Safety Considerations

The power module must be installed in compliance with the spacing and separation requirements of the end-user's safety agency standard, i.e. IEC 62368-1: 2014 (2nd edition), EN 62368-1: 2014 (2nd edition), UL 62368-1, 2nd Edition, 2014-12-01 and CSA C22.2 No. 62368-1-14, 2nd Edition, 2014-12. IEC 60950-1: 2005, 2nd Edition + A1: 2009 + A2: 2013, EN 60950-1: 2006 + A11: 2009 + A1: 2010 + A12: 2011 + A2: 2013, UL 60950-1, 2nd Edition, 2011-10-14 and CSA C22.2 No. 60950-1-07, 2nd Edition, 2010-14, if the system in which the power module is to be used must meet safety agency requirements.

Basic insulation based on 75Vdc input is provided between the input and output of the module for the purpose of applying insulation requirements when the input to this DC-to-DC converter is identified as TNV-2 or SELV. An additional evaluation is needed if the source is other than TNV-2 or SELV.

When the input source is SELV circuit, the power module meets SELV (safety extra-low voltage) requirements. If the input source is a hazardous voltage which is greater than 60 Vdc and less than or equal to 75 Vdc, for the module's output to meet SELV requirements, all of the following must be met:

- The input source must be insulated from the ac mains by reinforced or double insulation.
- The input terminals of the module are not operator accessible.
- If the metal baseplate / heatspreader is grounded the output must be also grounded.
- A SELV reliability test is conducted on the system where the module is used, in combination with the module, to ensure that under a single fault, hazardous voltage does not appear at the module's output.

When installed into a Class II equipment (without grounding), spacing consideration should be given to the end-use installation, as the spacing between the module and mounting surface have not been evaluated. The power module has extra-low voltage (ELV) outputs when all inputs are ELV.

This power module is not internally fused. To achieve optimum safety and system protection, an input line fuse is highly recommended. The safety agencies require a Fast-acting fuse with 30A maximum rating to be installed in the ungrounded lead. A lower rated fuse can be used based on the maximum inrush transient energy and maximum input current.

### Soldering and Cleaning Considerations

Post solder cleaning is usually the final board assembly process before the board or system undergoes electrical testing. Inadequate cleaning and/or drying may lower the reliability of a power module and severely affect the finished circuit board assembly test. Adequate cleaning and/or drying is especially important for un-encapsulated and/or open frame type modules. For assistance on appropriate soldering and cleaning procedures, please contact Delta's technical support team.

## FEATURES DESCRIPTIONS

### Over-Current Protection

The modules include an internal output over-current protection circuit, which will endure current limiting for an unlimited duration during output overload. If the output current exceeds the OCP set point, the modules will automatically shut down, and enter hiccup mode or latch mode, which is optional.

For hiccup mode, the module will try to restart after shutdown. If the overload condition still exists, the module will shut down again. This restart trial will continue until the overload condition is corrected.

For latch mode, the module will latch off once it shutdown. The latch is reset by either cycling the input power or by toggling the on/off signal for one second.

### Over-Voltage Protection

The modules include an internal output over-voltage protection circuit, which monitors the voltage on the output terminals. If this voltage exceeds the over-voltage set point, the module will shut down, and enter in hiccup mode or latch mode, which is optional. The default mode is hiccup mode.

For hiccup mode, the module will try to restart after shutdown. If the output overvoltage condition still exists, the module will shut down again. This restart trial will continue until the over-voltage condition is corrected.

For latch mode, the module will latch off once it shutdown. The latch is reset by either cycling the input power or by toggling the on/off signal for one second.

### Over-Temperature Protection

The over-temperature protection consists of circuitry that provides protection from thermal damage. If the temperature exceeds the over-temperature threshold the module will shut down, and enter in auto-restart mode or latch mode, which is optional.

For auto-restart mode, the module will monitor the module temperature after shutdown. Once the temperature is dropped and within the specification, the module will be auto-restart.

For latch mode, the module will latch off once it shutdown. The latch is reset by either cycling the input power or by toggling the on/off signal for one second.

### Remote On/Off

The remote on/off feature on the module can be either negative or positive logic. Negative logic turns the module on during a logic low and off during a logic high. Positive logic turns the modules on during a logic high and off during a logic low.

Remote on/off can be controlled by an external switch between the on/off terminal and the Vi(-) terminal. The switch can be an open collector or open drain.

For negative logic if the remote on/off feature is not used, please short the on/off pin to Vi(-). For positive logic if the remote on/off feature is not used, please leave the on/off pin floating.

The module will not response to the remote on/off signal which is less than 120us.

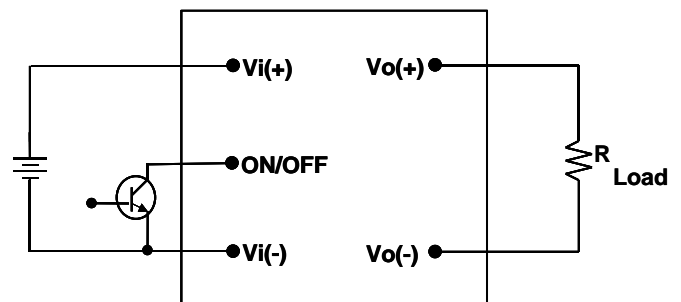


Figure 16: Remote on/off implementation



## THERMAL CONSIDERATIONS

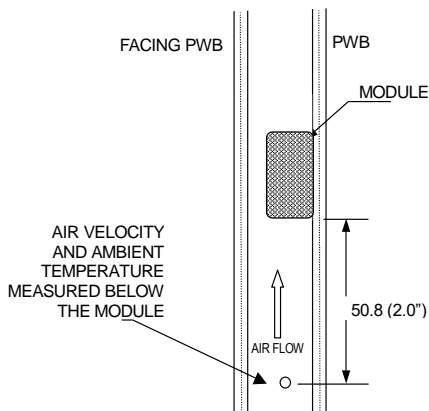
Thermal management is an important part of the system design. To ensure proper, reliable operation, sufficient cooling of the power module is needed over the entire temperature range of the module. Convection cooling is usually the dominant mode of heat transfer.

Hence, the choice of equipment to characterize the thermal performance of the power module is a wind tunnel.

### Thermal Testing Setup

Delta's DC/DC power modules are characterized in heated vertical wind tunnels that simulate the thermal environments encountered in most electronics equipment. This type of equipment commonly uses vertically mounted circuit cards in cabinet racks in which the power modules are mounted.

The following figure shows the wind tunnel characterization setup. The power module is mounted on a test PWB and is vertically positioned within the wind tunnel. The space between the neighboring PWB and the top of the power module is constantly kept at 6.35mm (0.25").



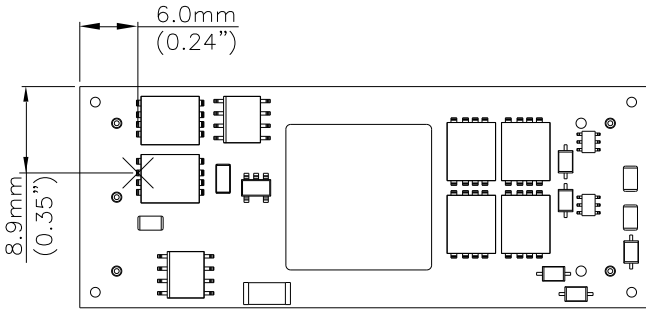
Note: Wind Tunnel Test Setup Figure Dimensions are in millimeters and (Inches)

Figure 17: Wind tunnel test setup

### Thermal Derating

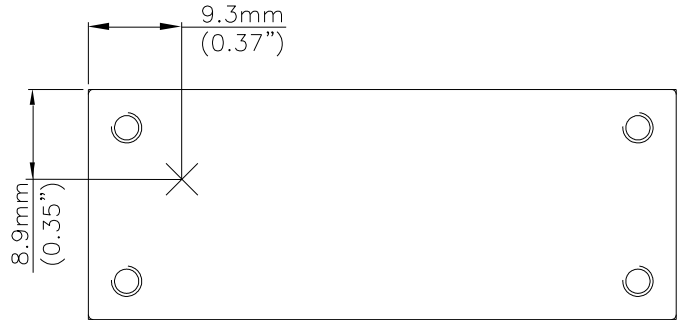
Heat can be removed by increasing airflow over the module. To enhance system reliability; the power module should always be operated below the maximum operating temperature. If the temperature exceeds the maximum module temperature, reliability of the unit may be affected.

## THERMAL CURVES (WITHOUT HEAT SPREADER)

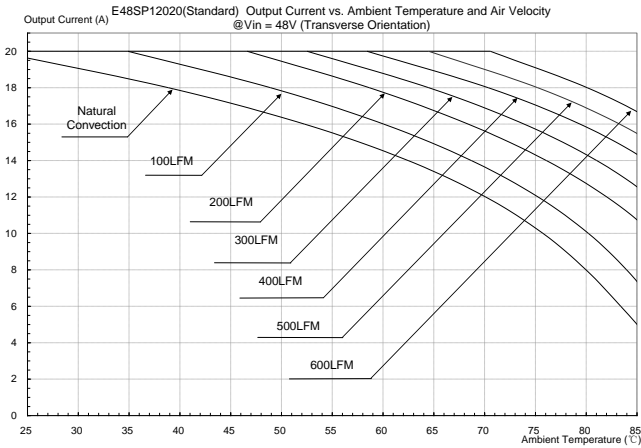


**Figure 18:** Temperature measurement location  
\* The allowed maximum hot spot temperature is defined at 122 °C

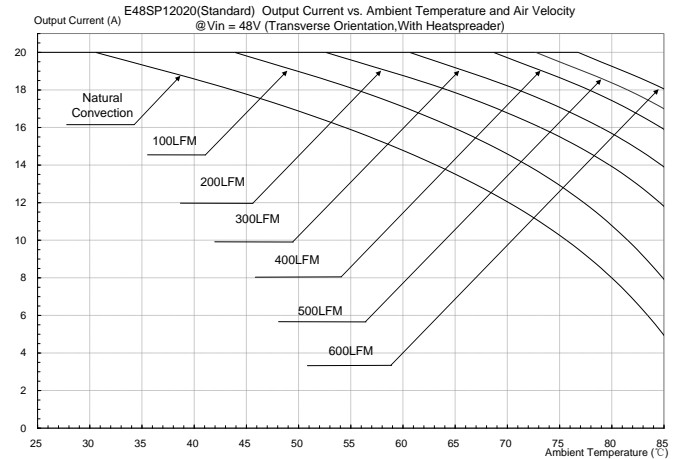
## THERMAL CURVES (WITH HEAT SPREADER)



**Figure 20:** Temperature measurement location  
\* The allowed maximum hot spot temperature is defined at 110 °C



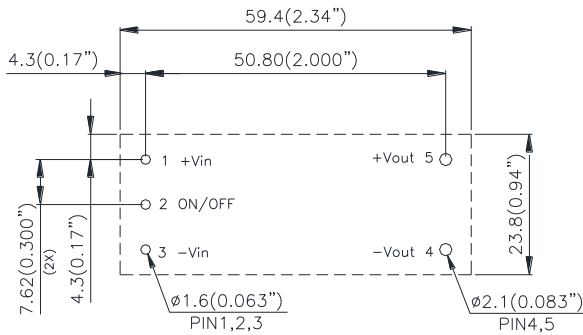
**Figure 19:** Output current vs. ambient temperature and air velocity @Vin=48V(Transverse Orientation, without heat spreader)



**Figure 21:** Output current vs. ambient temperature and air velocity @Vin=48V(Transverse Orientation, with heat spreader)



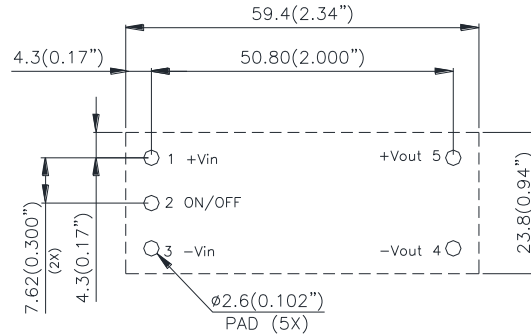
## RECOMMENDED PAD LAYOUT (THROUGH-HOLE MODULE)



RECOMENDED P.W.B. PAD LAYOUT

NOTES:  
 DIMENSIONS ARE IN MILLIMETERS AND (INCHES)  
 TOLERANCES: X.Xmm±0.5mm(X.XX in.±0.02 in.)  
 X.XXmm±0.25mm(X.XXX in.±0.010 in.)

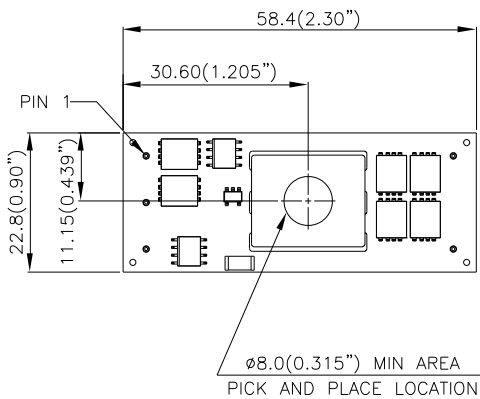
## RECOMMENDED PAD LAYOUT (SMD)



RECOMENDED P.W.B. PAD LAYOUT

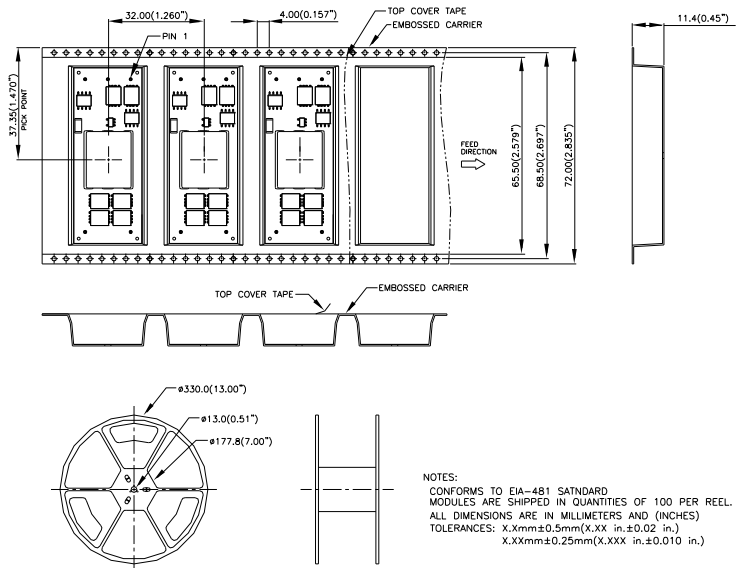
NOTES:  
 DIMENSIONS ARE IN MILLIMETERS AND (INCHES)  
 TOLERANCES: X.Xmm±0.5mm(X.XX in.±0.02 in.)  
 X.XXmm±0.25mm(X.XXX in.±0.010 in.)

## PICK AND PLACE LOCATION(SMD)



NOTES:  
 DIMENSIONS ARE IN MILLIMETERS AND (INCHES)  
 TOLERANCES: X.Xmm±0.5mm(X.XX in.±0.02 in.)  
 X.XXmm±0.25mm(X.XXX in.±0.010 in.)

## SURFACE-MOUNT TAPE & REEL(SMD)



NOTES:  
 CONFORMS TO EIA-481 SATNDARD  
 MODULES ARE SHIPPED IN QUANTITIES OF 100 PER REEL.  
 ALL DIMENSIONS ARE IN MILLIMETERS AND (INCHES)  
 TOLERANCES: X.Xmm±0.5mm(X.XX in.±0.02 in.)  
 X.XXmm±0.25mm(X.XXX in.±0.010 in.)

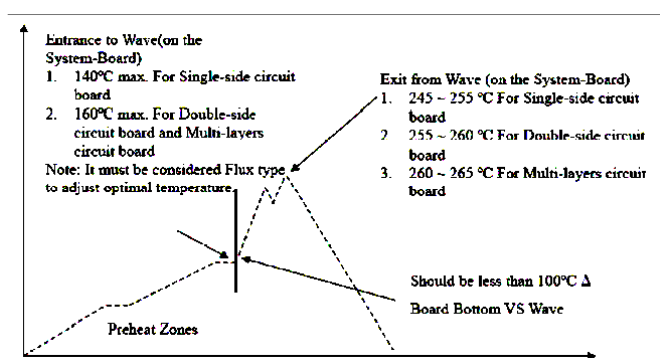
## SOLDERING METHOD

Generally, as the most common mass soldering method for the solder attachment, wave soldering is used for through-hole power modules and reflow soldering is used for surface-mount ones. Delta recommended soldering methods and process parameters are provided in this document for solder attachment of power modules onto system board. SAC305 is the suggested lead-free solder alloy for all soldering methods. The soldering temperature profile presented in this document is based on SAC305 solder alloy.

Reflow soldering is not a suggested method for through-hole power modules due to many process and reliability concerns. If you have this kind of application requirement, please contact Delta sales or FAE for further confirmation.

### Wave Soldering (Lead-free)

Delta's power modules are designed to be compatible with single-wave or dual wave soldering. The suggested soldering process must keep the power module's internal temperature below the critical temperature of 217°C continuously. The recommended wave-soldering profile is shown below:

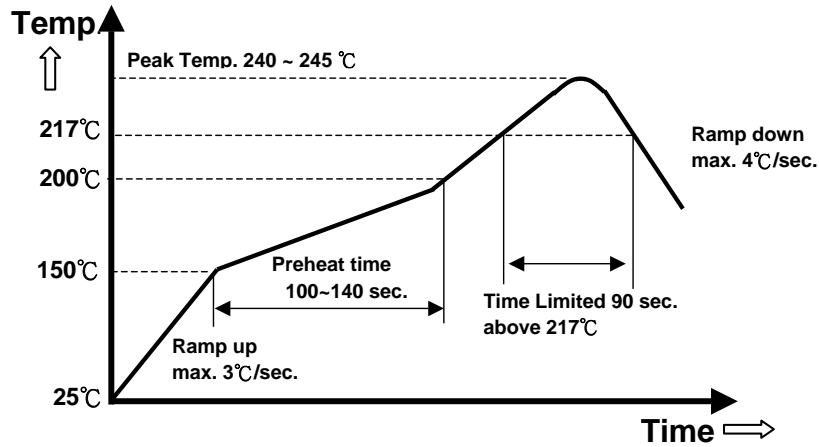


The typical recommended (for double-side circuit board) preheat temperature is 115+/-10°C on the top side (component side) of the circuit board. The circuit-board bottom-side preheat temperature is typically recommended to be greater than 135°C and preferably within 100°C of the solder-wave temperature. A maximum recommended preheat up rate is 3°C /s. A maximum recommended solder pot temperature is 255+/-5°C with solder-wave dwell time of 3-6 seconds. The cooling down rate is typically recommended to be 6°C/s maximum.

### Reflow Soldering (Lead-free)

High temperature and long soldering time will result in IMC layer increasing in thickness and thereby shorten the solder joint lifetime. Therefore, the peak temperature over 245°C is not suggested due to the potential reliability risk of components under continuous high-temperature. In the meanwhile, the soldering time of temperature above 217°C should be less than 90 seconds. Please refer to following fig for recommended temperature profile parameters.

Shielding cap is requested to mount on DCDC module if with heat-spreader/heat-sink, to prevent the customer side high temperature of reflow to re-melt the DCDC module's internal component's soldering joint.



*Note: The temperature is measured on solder joint of pins of power module.*

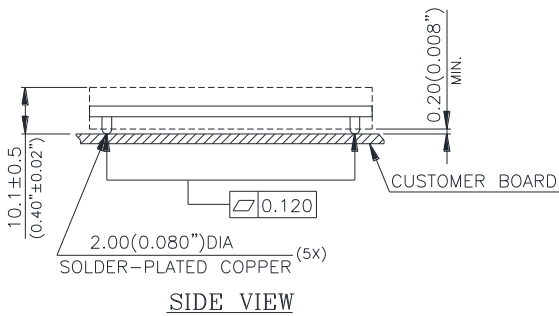
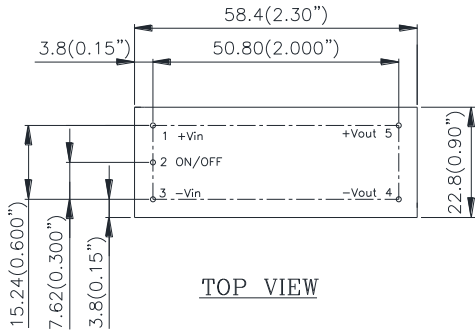
### Hand Soldering (Lead Free)

Hand soldering is the least preferred method because the amount of solder applied, the time the soldering iron is held on the joint, the temperature of the iron, and the temperature of the solder joint are variable. The recommended hand soldering guideline is listed in Table below. The suggested soldering process must keep the power module's internal temperature below the critical temperature of 217°C continuously.

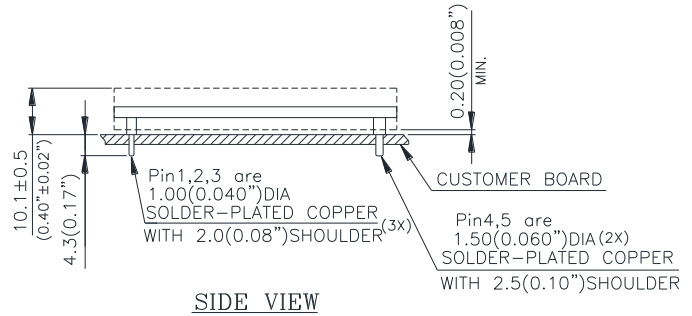
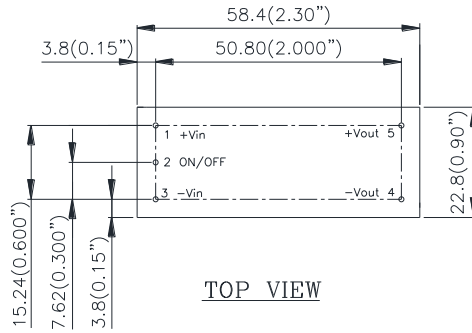
Parameter	Single-side Circuit Board	Double-side Circuit Board	Multi-layers Circuit Board
Soldering Iron Wattage	90	90	90
Tip Temperature	385+/-10°C	420+/-10°C	420+/-10°C
Soldering Time	2 ~ 6 seconds	4 ~ 10 seconds	4 ~ 10 seconds

# MECHANICAL DRAWING (WITHOUT HEATSPREADER)

## SURFACE-MOUNT MODULE



## THROUGH-HOLE MODULE

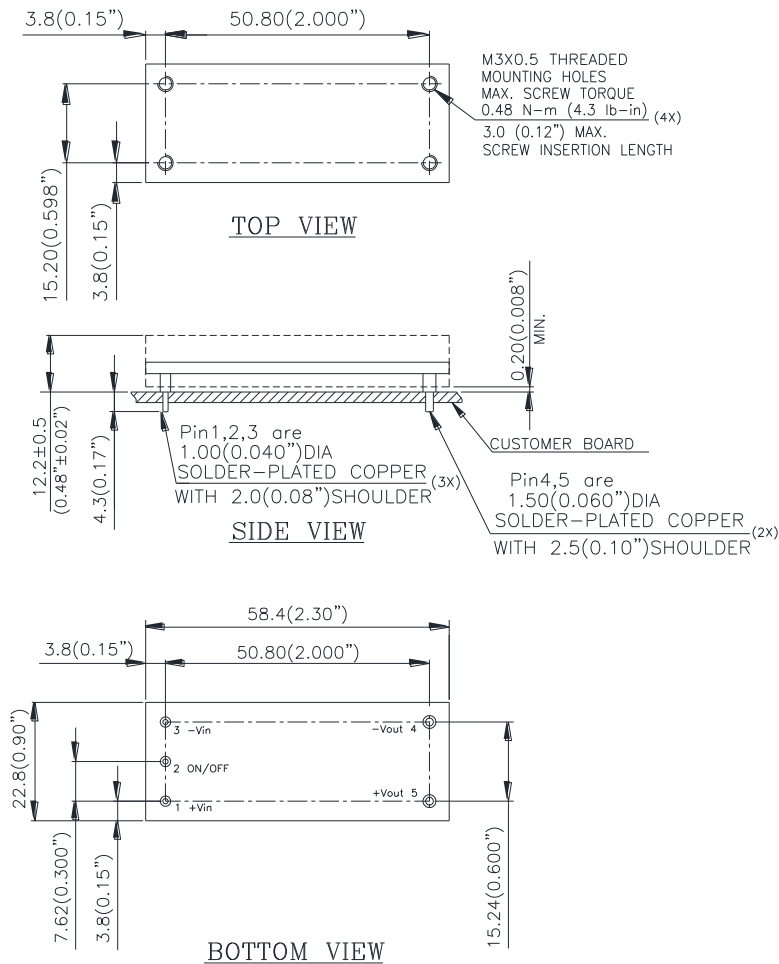


NOTES:  
 DIMENSIONS ARE IN MILLIMETERS AND (INCHES)  
 TOLERANCES: X.Xmm±0.5mm(X.XX in.±0.02 in.)  
 X.XXmm±0.25mm(X.XXX in.±0.010 in.)

## MECHANICAL DRAWING (WITH HEATSPREADER)

\*For modules with through-hole pins and the optional heatspreader, they are intended for wave soldering assembly onto system boards, please do not subject such modules through reflow temperature profile.

### THROUGH-HOLE MODULE



NOTES:  
DIMENSIONS ARE IN MILLIMETERS AND (INCHES)  
TOLERANCES: X.Xmm±0.5mm(X.XX in.±0.02 in.)  
X.XXmm±0.25mm(X.XXX in.±0.010 in.)

Pin No.	Name	Function
1	+Vin	Positive input voltage
2	ON/OFF	Remote ON/OFF
3	-Vin	Negative input voltage
4	-Vout	Negative output voltage
5	+Vout	Positive output voltage

#### Pin Specification:

Pins 1-3 1.00mm (0.040") diameter  
Pins 4 & 5 1.50mm (0.060") diameter

Note: All pins are copper alloy with matte Tin (Pb free) plated over Nickel under plating

## PART NUMBERING SYSTEM

E	48	S	P	120	20	N	R	F	A
Type of Product	Input Voltage	Number of Outputs	Product Series	Output Voltage	Output Current	ON/OFF Logic	Pin Length/Type		Option Code
E - Eighth Brick	48 - 36V~75V	S - Single	P - High Power	120 - 12V	20 - 20A	N - Negative	R - 0.170" N - 0.145" S - 0.188" T - 0.220" M - SMD	F - RoHS 6/6 (Lead Free)	A - Standard H - With heatspreader

\*E48SP12020NMFA can be processed with reflow process.

## RECOMMENDED PART NUMBER

MODEL NAME	INPUT		OUTPUT		EFF @ 100% LOAD
E48SP12020NRFA	36V~75V	9A	12V	20A	94.5%
E48SP12020NRFH	36V~75V	9A	12V	20A	94.5%

\*E48SP12020NRFH with conformal coating, thickness about 1mil

Default remote on/off logic is negative and pin length is 0.170"

For different remote on/off logic and pin length, please refer to part numbering system above or contact your local sales office.

***\*For modules with through-hole pins and the optional heatspreader, they are intended for wave soldering assembly onto system boards, please do not subject such modules through reflow temperature profile.***

**CONTACT:** [www.deltaww.com/dcdc](http://www.deltaww.com/dcdc)

**EMAIL:** [dcdc@deltaww.com](mailto:dcdc@deltaww.com)

### USA:

Telephone:  
East Coast: 978-656-3993  
West Coast: 510-668-5100  
Fax: (978) 656 3964

### Europe:

Telephone: +31-20-655-0967  
Fax: +31-20-655-0999

### Asia & the rest of world:

Telephone: +886 3 4526107 x 6220~6224  
Fax: +886 3 4513485

## WARRANTY

Delta offers a two (2) year limited warranty. Complete warranty information is listed on our web site or is available upon request from Delta.

Information furnished by Delta is believed to be accurate and reliable. However, no responsibility is assumed by Delta for its use, nor for any infringements of patents or other rights of third parties, which may result from its use. No license is granted by implication or otherwise under any patent or patent rights of Delta. Delta reserves the right to revise these specifications at any time, without notice.