

FEATURES

Electrical

- ◆ Peak Efficiency up to 97.3%
- ◆ Over current protection
- ◆ Input UVP/OVP
- ◆ Over Temperature Protection
- ◆ Remote ON/OFF
- ◆ Pre-bias startup
- ◆ No minimum load required
- ◆ Active Droop Performance
- ◆ Parallel Operation with Direct Output connection
- ◆ PMBus Communication
- ◆ 707Vdc isolation

Mechanical

Size:

- 58.4 x 36.8 x 13.2mm
(2.30"x1.45"x0.52") without heat-spreader
- 58.4 x 36.8 x 15.0mm
(2.30"x1.45"x0.59") with heat-spreader
- 58.4 x 36.8 x 27.0mm
(2.30"x1.45"x1.06") with heat-spreader and heat-sink

Safety & Reliability

- ◆ IEC/EN/UL/CSA 62368-1, 2nd edition
- ◆ IEC/EN/UL/CSA 60950-1, 2nd edition+A2
- ◆ ISO 9001, TL 9000, ISO 14001, QS 9000,
- ◆ OHSAS18001 certified manufacturing facility

SOLDERING METHOD

- ◆ Wave soldering
- ◆ Hand soldering

OPTIONS

- ◆ Negative/Positive Remote on/off
- ◆ Analog/Digital option

APPLICATIONS

- ◆ Optical Transport
- ◆ Data Networking
- ◆ Communications
- ◆ Servers



Photo is for reference only

Q54SH12084

Quarter Brick DC/DC Power Module

40~60V in, 11.8V/84.8A out, 1000W

The Q54SH12084, quarter brick, 40~60V input, single output 11.8V, isolated DC/DC converter is the latest offering from a world leader in power system and technology and manufacturing — Delta Electronics, Inc. This product provides up to 1000 watts of power at 40~60V input in an industry standard footprint and pin out. With creative design technology and optimization of component placement, these converters possess outstanding electrical and thermal performances, as well as extremely high reliability under highly stressful operating conditions. The Q54SH12084 offers peak 97.3% high efficiency. The Q54SH12084 is fully protected from abnormal input/output voltage, current, and temperature conditions and meets 707V isolation. And it can be connected in parallel directly for higher power without external oring-fet.



T_A=25°C, airflow rate=300 LFM, V_{in}=54Vdc, nominal V_{out} unless otherwise noted.)

PARAMETER	NOTES and CONDITIONS	Q54SH12084			
		Min.	Typ.	Max.	Units
ABSOLUTE MAXIMUM RATINGS					
Input Voltage					Vdc
Continuous		0		60	Vdc
Transient	10mS			63	Vdc
Operating Ambient Temperature (Ta)		-20		85	°C
Storage Temperature		-55		125	°C
Input/output Isolation Voltage				707	Vdc
INPUT CHARACTERISTICS					
Operating Input Voltage		40	54	60	Vdc
Input Under-Voltage Lockout					
Turn-On Voltage Threshold		39	39.5	40	Vdc
Turn-Off Voltage Threshold		37	38	39	Vdc
Lockout Hysteresis Voltage		1	1.5		Vdc
Input Over-Voltage Protection		61	62		Vdc
Maximum Input Current	Full Load, 40V _{in}			27	A
No-Load Input Current	V _{in} =54V, I _o =0A		300		mA
Off Converter Input Current	V _{in} =54V		15		mA
Internal Input Filter	L + C Structure		40+23		nH+μF
Internal Input Ripple Current				700	mArms
OUTPUT CHARACTERISTICS					
Output Voltage Set Point	V _{in} =54V, I _o =Open Load, T _c =25°C	12.16	12.20	12.24	Vdc
	V _{in} =54V, I _o =Full Load, T _c =25°C	11.76	11.80	11.84	Vdc
Output Regulation					
Load Regulation	V _{in} =54V, I _o =I _o min to I _o max		400		mV
Line Regulation	V _{in} =40V to 60V, I _o =0			0.4	%Vo,set
Temperature Regulation	T _a =-20°C to 85°C	-1	0	1	%Vo,set
Total Output Voltage Range	Over sample load, line and temperature	11.6		12.4	V
Output Voltage Ripple and Noise	5Hz to 20MHz bandwidth				
Peak-to-Peak	Full Load, Co=990uF Oscon cap, 110μF Ceramic cap		85	150	mV
RMS	Full Load, Co=990uF Oscon cap, 110μF Ceramic cap		25	50	mV
Operating Output Current Range		0		84.8	A
Output Over Current Protection(hiccup mode)	when V _o <10%V _{o,nom}	110	125	140	%I _{o,max}
Output Over Voltage Protection(hiccup mode)			13.5	15	V
DYNAMIC CHARACTERISTICS					
Output Voltage Current Transient	Co=990uF Oscon cap, 110μF Ceramic cap, 1A/μs				
Positive Step Change in Output Current	75% I _{o,max} to 50% I _{o,max}			350	mV
Negative Step Change in Output Current	50% I _{o,max} to 75% I _{o,max}			350	mV
Settling Time (within 1% nominal V _{out})			200		μs
Turn-On Delay Time					
Start-Up Delay Time From Input Voltage	On/Off=On, from V _{in} =Turn-on Threshold to V _o =10% V _{o,nom}	5		55	mS
Start-Up Delay Time From On/Off Control	V _{in} =V _{in,nom} , from On/Off=On to V _o =10% V _{o,nom}	0		10	mS
Output Voltage Rise Time	V _o =10% to 90% V _{o,nom}	5		25	mS
Output Capacitance Range	10% ceramic, 90% Oscon or AL	1000		10000	μF
EFFICIENCY					
Half Load Efficiency	50% Load @V _{in} =54Vdc		96.8		%
Peak Efficiency	75% Load @V _{in} =54Vdc		97.3		%
Full Load Efficiency	100% Load @V _{in} =54Vdc		97.2		%
ISOLATION CHARACTERISTICS					
Input to Output				707	Vdc
Isolation Capacitance			100		nF
FEATURE CHARACTERISTICS					
Switching Frequency	V _{in} =40~60V	330		1100	KHz
On/Off Control, Negative Remote On/Off logic					
Logic Low (Module On)	V _{on/off}			0.8	V
Logic High (Module Off)	V _{on/off}	2.4		20	V
ON/OFF Current	I _{on/off} at V _{on/off} =0.0V			0.2	mA
Leakage Current	Logic High, V _{on/off} =15V	10		500	uA

PARAMETER	NOTES and CONDITIONS	Q54SH12084			
		Min.	Typ.	Max.	Units
GENERAL SPECIFICATIONS					
MTBF	$I_o=80\%$ of $I_{o,max}$; $T_a=25^\circ\text{C}$ With Heat-spreader With Heat-spreader and heat-sink Refer to Figure 17 for Hot spot 1 location (54Vin, 80% Io, 200LFM, Airflow from Vin+ to Vin-) Refer to Figure 19 for Hot spot 2 location (54Vin, 80% Io, 200LFM, Airflow from Vin+ to Vin-) Refer to Figure 21 for Hot spot 3 location (54Vin, 80% Io, 200LFM, Airflow from Vout to Vin) Note: Please attach thermocouple on NTC resistor to test OTP function, the hot spots' temperature is just for reference.	5.6			Mhours
Weight		80			grams
Weight		100			grams
Over-Temperature Shutdown (With heat-spreader)		134			$^\circ\text{C}$
Over-Temperature Shutdown (With 0.5" Height Transverse Heat Sink QTL050A)		134			$^\circ\text{C}$
Over-Temperature Shutdown (With 0.5" Height Longitudinal Heat Sink QLL050A)		134			$^\circ\text{C}$
Over-Temperature Shutdown (NTC Resistor)	130			$^\circ\text{C}$	
PMBUS SIGNAL INTERFACE CHARACTERISTICS					
Logic Input Low (VIL)	Data, SMBAlert, Clock pin	0		0.8	V
Logic Input High (VIH)	Data, SMBAlert, Clock pin	2.4		3.6	V
Logic Output Low (VOL)	Data, SMBAlert, Clock pin; IOL=4mA			0.4	V
Logic Output High (VOH)	Data, SMBAlert, Clock pin; IOH=-4mA	2.5			V
PMBus Operating Frequency Range			100/400		KHz
PMBUS MONITORING CHARACTERISTICS					
Output Current Reading Accuracy	Vin=54V, Io=50% ~ 100% of Io, max;	-5		+5	%
	Vin=54V, Io=5% ~ 50% of Io, max;	-2.1		+2.1	A
Output Voltage Reading Accuracy		-2		+2	%
Input Voltage Reading Accuracy		-4		+4	%
Temperature Reading Accuracy		-5		+5	$^\circ\text{C}$

Typical Application Circuit

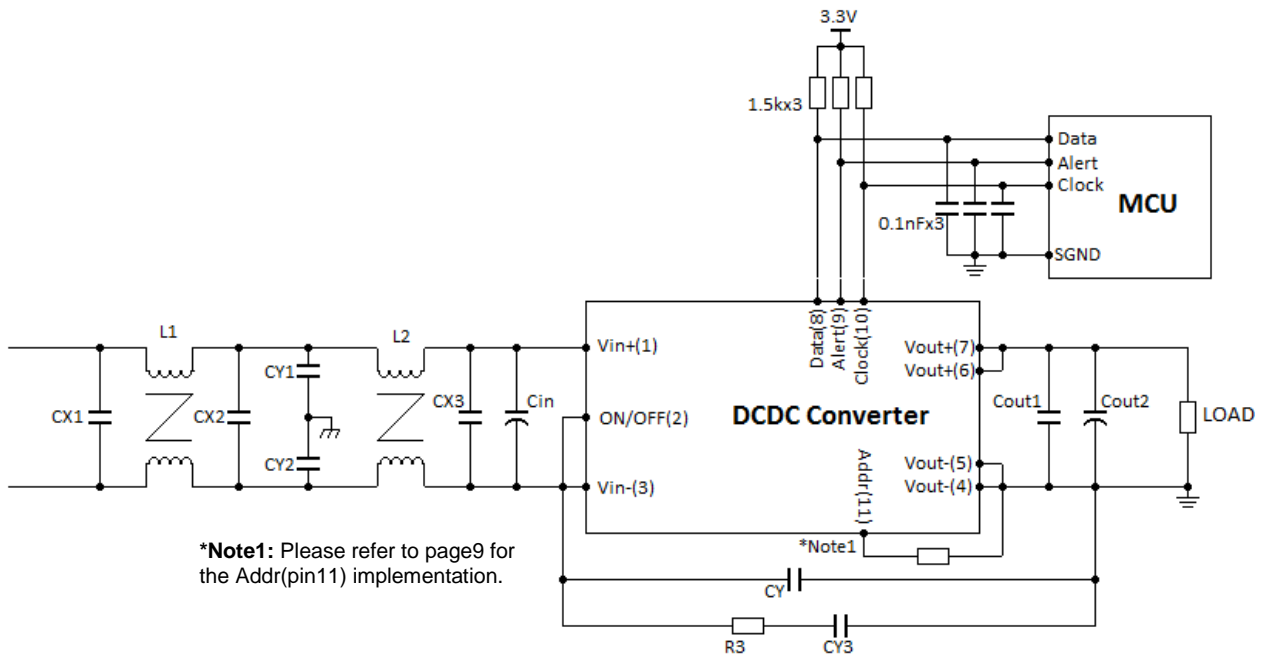

Location	Vendor P/N	Description	Qty	Vendor	Purpose
Cin	100ZLJ100MEFC10*20	100V 100uF M 10*20	3	RUBYCON	For stable operation
CX3	C3225X7R2A225KT5	100V 2.2uF K X7R 1210	4	TDK	
Cout1	GRM31CC71C226M	CAP MC SMD 16V 22uF M X7S 1206 1.6	5	MURATA	
Cout2	APSG250ETD331MJB5S	CAP AL SP 25V 330uF M 10*11.5 TP P5	3	NCC	
CY3	C1210X333K102TZ	CAP MC SMD 1KV 0.033uF K X7R 1210 EPOXY	3	HOLY STONE	For EMC
R3	RMH10FT1R00	RES SMD 1/4W 1ohm F 0805	1	TA-I	
CY1,CY2	C3216X7R2E473KT5	CAP MC SMD 250V 0.047uF K X7R 1206 OPEN	2	TDK	
CX1	C3225X7R2A225KT5	100V 2.2uF K X7R 1210	4	TDK	
CX2			2	TDK	
L1,L2	P0502NLT	COMMON MODE CHOKE 14A 2LN SMD	2	PULSE	
CY	C1210X333K102TZ	CAP MC SMD 1KV 0.033uF K X7R 1210 EPOXY	7	HOLY STONE	

*The components for EMC purpose can be deleted if the function is not needed.

$T_A=25^{\circ}\text{C}$

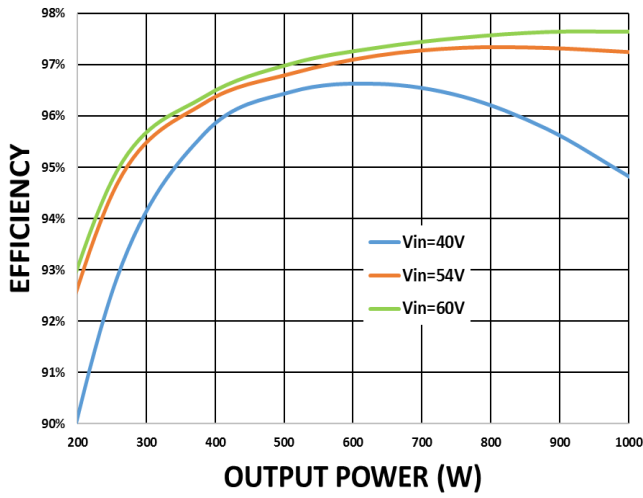

Figure 1: Efficiency vs. Output Power

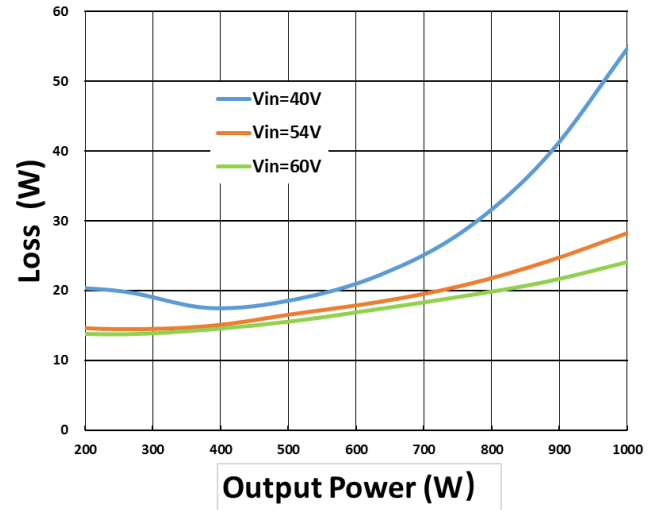

Figure 2: Loss vs. Output Power

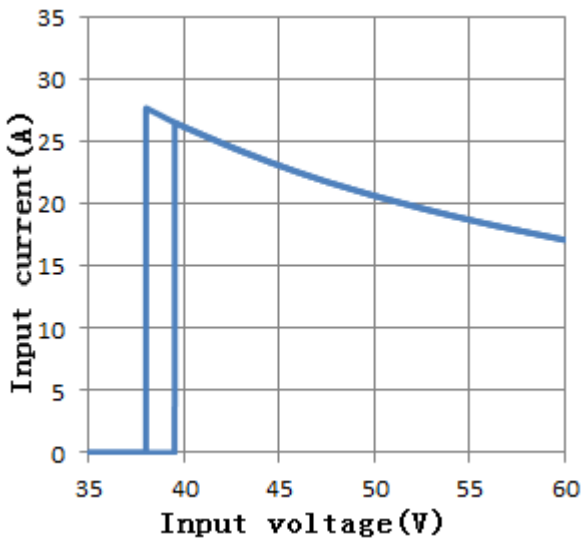

Figure 3: Full Load Input Characteristics

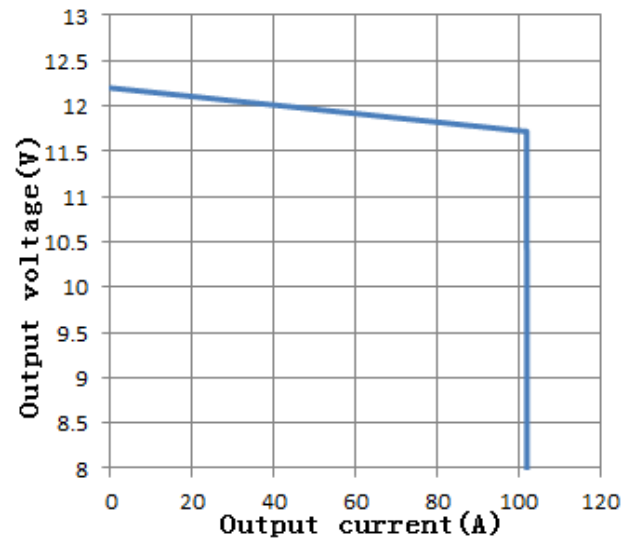

Figure 4: Output Voltage vs. Output Current showing typical current limit curves and converter shutdown points.

$T_A=25^{\circ}\text{C}$,

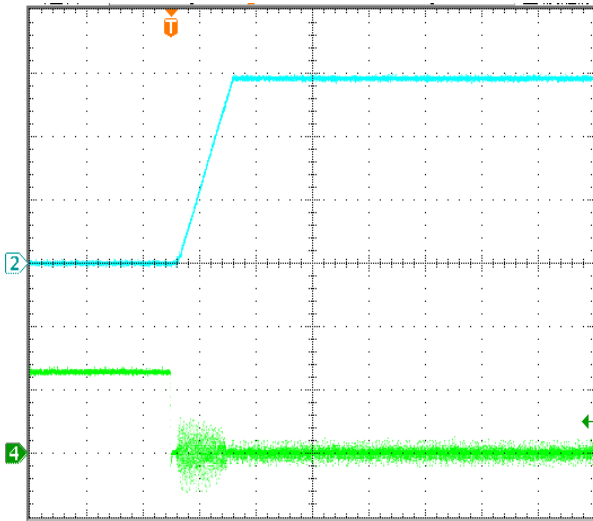

Figure 5: Remote On/Off (negative logic) at full load

$V_{in}=54\text{V}$, $I_{out} = I_{o, max}$

Time: 10ms/div.

V_{out} (top trace): 4V/div;

$V_{remote\ On/Off\ signal}$ (bottom trace): 2V/div.

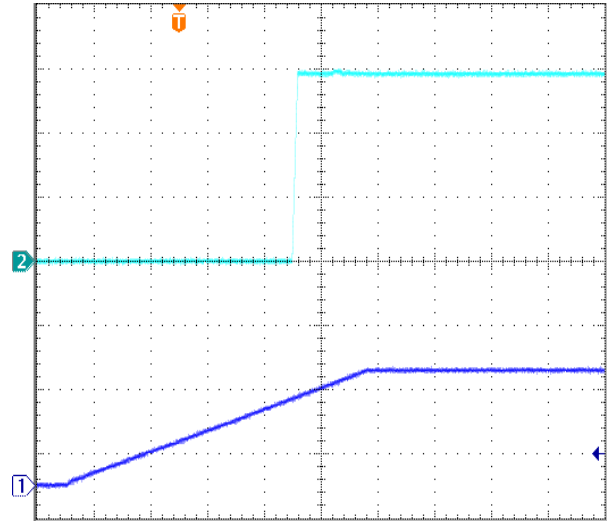

Figure 6: Input Voltage Start-up at full load

$V_{in}=54\text{V}$, $I_{out} = I_{o, max}$

Time: 100ms/div.

V_{out} (top trace): 4V/div;

V_{in} (bottom trace): 30V/div.

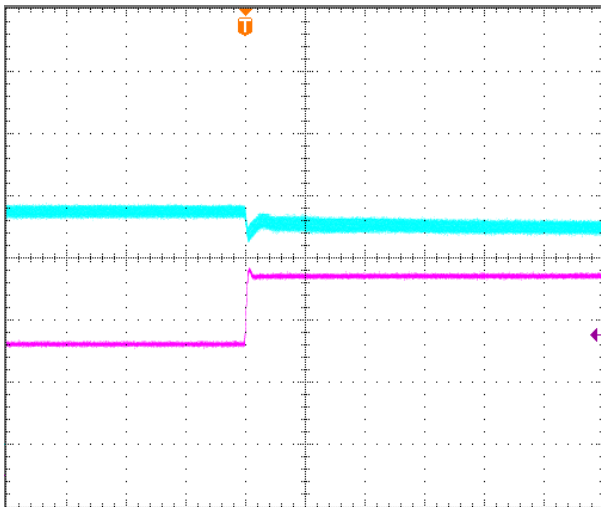

Figure 7: Transient Response

($V_{in}=54\text{V}$, 1A/ μs step change in load from 50% to 75% of $I_{o, max}$)

V_{out} (top trace): 0.5 V/div, 400us/div;

I_{out} (bottom trace): 20A/div.

Load cap: 22uF/16V/X7S*5pcs ceramic cap + 330uF/25V*3pcs Oscon cap.

Scope measurement should be made using a BNC cable (length shorter than 20 inches). Position the load between 51 mm to 76 mm (2 inches to 3 inches) from the module

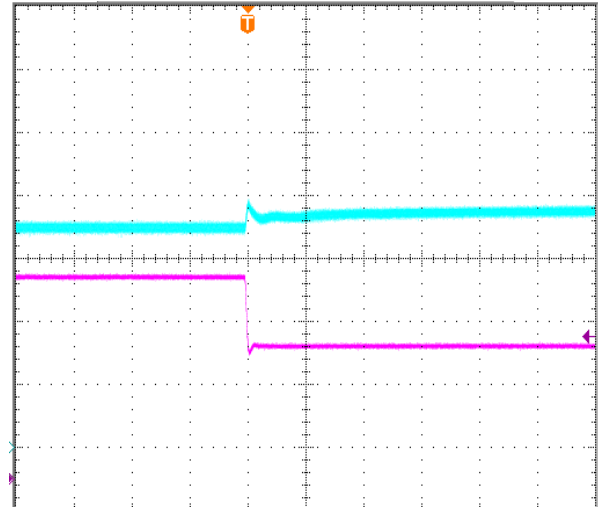

Figure 8: Transient Response

($V_{in}=54\text{V}$, 1A/ μs step change in load from 75% to 50% of $I_{o, max}$)

V_{out} (top trace): 0.5V/div, 400us/div;

I_{out} (bottom trace): 20A/div.

Load cap: 22uF/16V/X7S*5pcs ceramic cap + 330uF/25V*3pcs Oscon cap.

Scope measurement should be made using a BNC cable (length shorter than 20 inches). Position the load between 51 mm to 76 mm (2 inches to 3 inches) from the module

$T_A=25^{\circ}\text{C}$, $V_{in}=54\text{Vdc}$

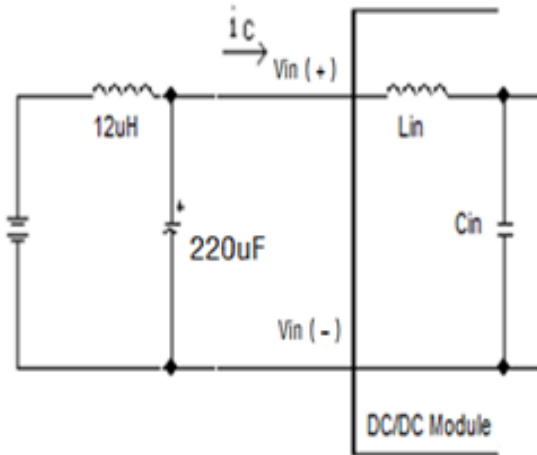

Figure 9: Test Setup Diagram for Input Ripple Current
 Note: Measured input reflected-ripple current with a simulated source Inductance of $12\mu\text{H}$. Measure current as shown above.

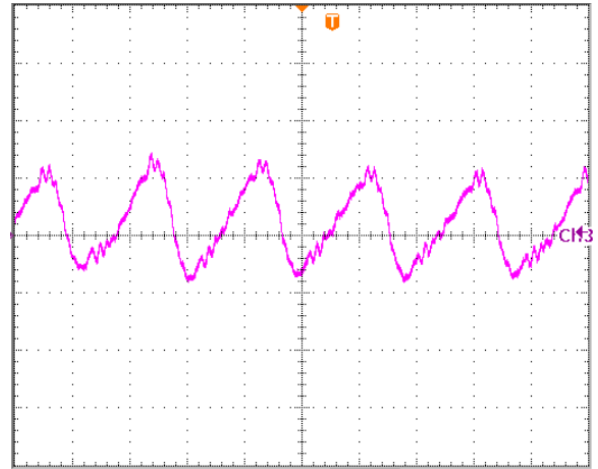

Figure 10: Input Terminal Ripple Current, i_c , at max output current and nominal input voltage with $12\mu\text{H}$ source impedance and $220\mu\text{F}$ electrolytic capacitor (50 mA/div, 1us/div).

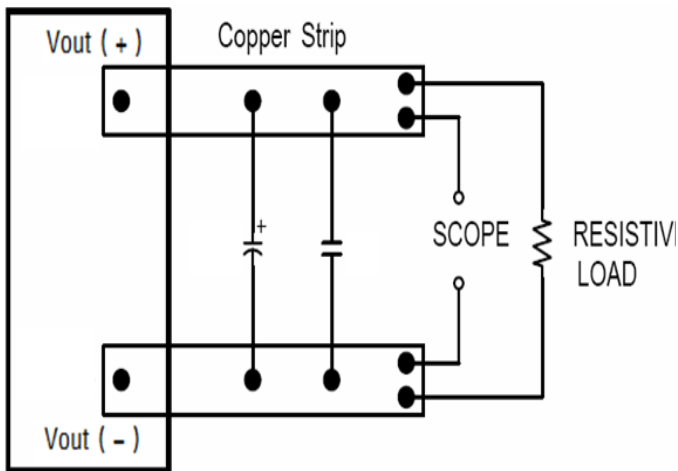

Figure 11: Test Setup for Output Voltage Noise and Ripple

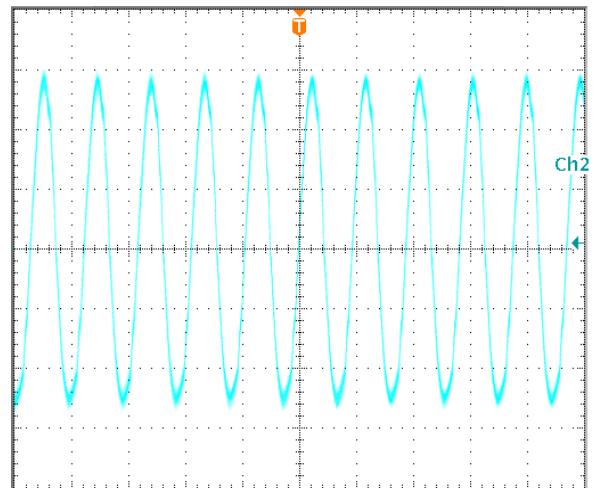

Figure 12: Output Voltage Ripple and Noise at nominal input voltage and max load current (10 mV/div, 1us/div)
 Load cap: $22\mu\text{F} \times 5$ pcs ceramic cap, $330\mu\text{F} \times 3$ pcs Oscon cap.
 Bandwidth: 20MHz.

Input Source Impedance

The impedance of the input source connecting to the DC/DC power modules will interact with the modules and affect the stability. A low ac-impedance input source is recommended. A low ESR electrolytic capacitor higher than 220 μ F (ESR < 0.7 Ω at 100kHz) is suggested.

Layout and EMC Considerations

Delta's DC/DC power modules are designed to operate in a wide variety of systems and applications. For design assistance with EMC compliance and related PWB layout issues, please contact Delta's technical support team. Below is the reference design for an input filter and tested result which can meet class B in CISPR 22.

Schematic and Components List

Cin are 100 μ F low ESR Aluminum cap \times 3pcs in parallel+2.2 μ F ceramic cap \times 4pcs;
 CX1 is 2.2 μ F ceramic cap \times 4pcs in parallel;
 CY1 and CY2 are 88nF ceramic cap;
 CX2 is 2.2 μ F ceramic cap \times 2pcs in parallel;
 CY is 220nF;
 CY3 is 100nF, R3 is 1ohm;
 L1 and L2 is 0.22mH;

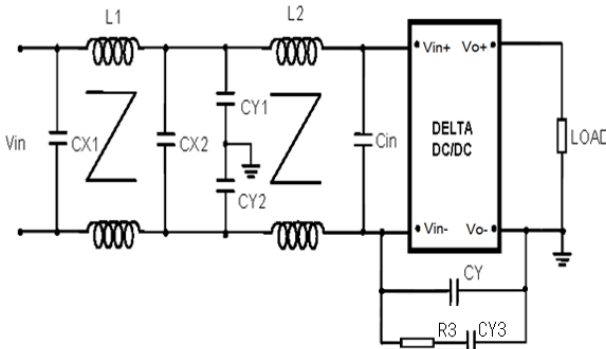

Figure 13-1: Recommended Input Filter

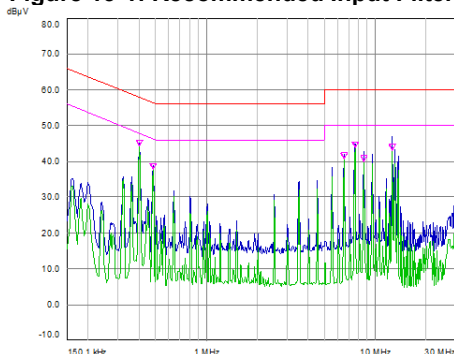

Figure 13-2: Test Result of EMC ($V_{in}=54V$, $I_o=84.8A$).

Note: Input EMI filter is recommended in front of power module application. For incomplete EMI circuit, EMI risk does exist in the system. For example, the parasitic inductance of long input cable may form LC resonant circuit with Y capacitance. Undesired oscillation may happen if the resonant frequency is within the switching frequency range of the power module. An RC circuit (R3/CY3 are 1ohm/100nF) as shown in Figure 13 is strongly recommended even there is no EMI requirement for the DCDC converter. If customer encounter any EMI issue, please contact Delta design team for solution.

DESIGN CONSIDERATIONS

Safety Considerations

The power module must be installed in compliance with the spacing and separation requirements of the end-user's safety agency standard, i.e. IEC 62368-1: 2014 (2nd edition), EN 62368-1: 2014 (2nd edition), UL 62368-1, 2nd Edition, 2014-12-01 and CSA C22.2 No. 62368-1-14, 2nd Edition, 2014-12. UL60950-1, CSA C22.2 NO. 60950-1 2nd, IEC 60950-1 2nd: 2005, EN 60950-1 2nd: 2006+A11+A1: 2010, if the system in which the power module is to be used must meet safety agency requirements.

Both the input and output of this product meet SELV requirement. This module has function insulation with 707Vdc isolation. This power module is not internally fused. To achieve optimum safety and system protection, an input line fuse is highly recommended. The safety agencies require a normal-blow fuse with 40A maximum rating to be installed in the ungrounded lead. A lower rated fuse can be used based on the maximum inrush transient energy and maximum input current.

Soldering and Cleaning Considerations

Post solder cleaning is usually the final board assembly process before the board or system undergoes electrical testing. Inadequate cleaning and/or drying may lower the reliability of a power module and severely affect the finished circuit board assembly test. Adequate cleaning and/or drying is especially important for un-encapsulated and/or open frame type power modules. For assistance on appropriate soldering and cleaning procedures, please contact Delta's technical support team.

Remote On/Off

The remote on/off feature on the module is negative logic. Negative logic turns the module on during a logic low and off during a logic high. Remote on/off can be controlled by an external switch between the on/off terminal and the Vin (-) terminal. The switch can be an open collector or open drain. For negative logic if the remote on/off feature is not used, please short the on/off pin to Vin (-). The DC level on/off signal is suggested.

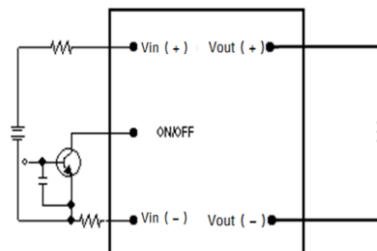

Figure 14: Remote On/Off Implementation

Over-Current Protection

The modules include an internal output over-current protection circuit, which will endure current limiting for an unlimited duration during output overload. If the output current exceeds the OCP set point, the modules will shut down (hiccup mode). The modules will try to restart after shutdown. If the overload condition still exists, the module will shut down again. This restart trial will continue until the overload condition is corrected.

Over-Voltage Protection

The modules include an internal input over-voltage protection circuit, which monitors the voltage on the input terminals. If this voltage exceeds the over-voltage set point, the protection circuit will shut down, and then restart with a time delay after the fault no long exist.

Over-Temperature Protection

The over-temperature protection consists of circuitry that provides protection from thermal damage. If the temperature exceeds the over-temperature threshold the module will shut down. The module will restart after the temperature is within specification.

Parallel and Droop Current Sharing

The modules are capable of operating in parallel, and realizing current sharing by droop current sharing method. There is about 400mV output voltage droop from 0A to full output Load, and there is no current sharing pin. By connecting the Vin pin and the Vo pin of the parallel module together, the current sharing can be realized automatically.

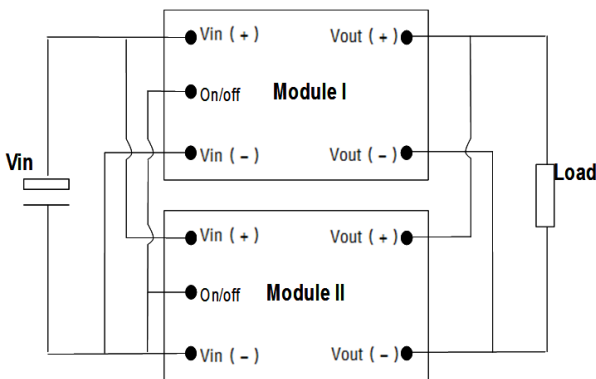

Figure 15: Parallel and droop current sharing configuration for no redundancy requirement system

If system has no redundancy requirement, the module can be parallel directly for higher power without adding external oring-fet; whereas, If the redundancy function is required, the external oring-fet should be added.

For a normal parallel operation, the following precautions must be observed:

- The current sharing accuracy equation is:

$$X\% = |I_{o1} - I_o / 2| / I_{rated}$$
 Where,
 I_{o1} is the output current of module1;
 I_o is the output current of total;
 I_{rated} is the rated full load current of per module.
- To ensure a better steady current sharing accuracy, below design guideline should be followed:
 - The inputs of the converters must be connected to the same voltage source; and the PCB trace resistance from Input voltage source to Vin+ and Vin- of each converter should be equalized as much as possible.
 - The PCB trace resistance from each converter's output to the load should be equalized as much as possible.

- For accurate current sharing accuracy test, the module should be soldered in order to avoid the unbalance of the touch resistance between the modules to the test board.

3. To ensure the parallel module can start up monotonically without triggering the OCP circuit, below design guideline should be followed:

- Before all the parallel modules finished start up, the total load current should be lower than the rated current of 1 module.
- The ON/OFF pin of the converters should be connected together to keep the parallel modules start up at the same time.
- The under voltage lockout point will slightly vary from unit to unit. The dv/dt of the rising edge of the input source voltage must be greater than 1V/ms to ensure that the parallel module start up at the same time.

PMBus Communication

The module has a digital PMBus interface to allow the module to be monitored, controlled and configured by the system. The module supports 4 PMBus signal lines, Data, Clock, SMBALERT (optional), and 1 Address line Addr1. More detail PMBus information can be found in the PMB Power Management Protocol Specification, Part I and part II, revision 1.2; which is shown in <http://pmbus.org>. Both 100kHz and 400kHz bus speeds are supported by the module. Connection for the PMBus interface should be following the High Power DC specifications given in section 3.1.3 in the SMBus specification V2.0 or the Low Power DC specifications in section 3.1.2. The complete SMBus specification is shown in <http://smbus.org>.

Note: If a series of commands consecutively sending to this module more than 30ms time, the bus free time between stop and start condition (TBUF) that defined in SMBUS AC specifications should not be all less than 200us in these commands.

The module supports the Packet Error Checking (PEC) protocol. It can check the PEC byte provided by the PMBus master, and include a PEC byte in all message responses to the master.

SMBALERT protocol is also supported by the module. SMBALERT line is also a wired-AND signal; by which the module can alert the PMBUS master via pulling the SMBALERT pin to an active low. There are two ways that the master and the module response to the alert of SMBALERT line.

One way is for the module used in a system that does not support Alert Response Address (ARA). The module is to retain its resistor programmed address, when it is in an ALERT active condition. The master will communicate with the slave module using the programmed address, and using the various READ_STATUS commands to find who cause for the SMBALERT. The CLEAR_FAULTS command will clear the SMBALERT.

The module contains a data flash used to store configuration settings, which will not be programmed into the device data flash automatically. The STORE_DEFAULT_ALL command must be used to commit the current settings are transfer from RAM to data flash as device defaults

PMBUS Addressing

The Module has flexible PMBUS addressing capability. When connect different resistor from Addr1 pin to Vout(-) pin, 14 possible addresses can be acquired.

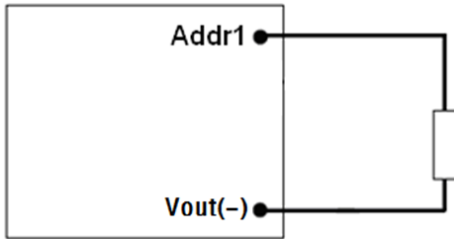

Different PMBUS address is defined by the value of the resistor as below, and +/-1% resistors accuracy can be accepted. If there is any resistance exceeding the requested range, address 126 will be return.

PMBUS address	Resistor(Kohm)
96	10
97	15
98	21
99	28
100	35.7
101	45.3
102	56.2
103	69.8
104	88.7
105	107
106	130
107	158
108	191
109	232

Address 127 (or 0x7F) is reserved address by PMBUS. The built-in digital PWM controller uses this address for Factory test purposes, and will ack this address. Application should not use this address either.

PMBus Data Format

The module receives and report date in LINEAR format. The Exponent of the data words is fixed at a reasonable value for the command; altering the exponent is not supported. DIRECT format is not supported by the module.

For commands that set or report any voltage thresholds related to the output voltage, the module supports the linear data format consisting of a two-byte value with a 16-bit, unsigned mantissa, and a fixed exponent of -12. The format of the two data bytes is shown below:

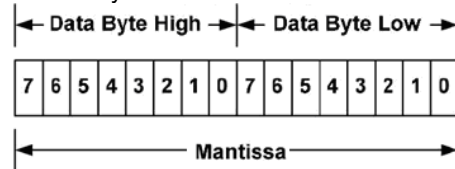

The equation can be written as:

$$V_{out} = \text{Mantissa} \times 2^{-12}$$

For example, considering set Vout to 12V by VOUT_COMMAND, the read/write data can be calculated refer to below process:

1. Mantissa = $V_{out}/2^{-12} = 12/2^{-12} = 49152$;
2. Converter the calculated Mantissa to hexadecimal 0xC000.

For example, considering set the turn on threshold of input under voltage lockout to 34V by VIN_ON command; the read/write data can be calculated refer to below process:

1. Get the exponent of Vin, -3; whose binary is 11101
2. Mantissa = $V_{in}/2^{-3} = 34/2^{-3} = 272$;
3. Converter the calculated Mantissa to hexadecimal 110, then converter to binary 00100010000;
4. Combine the exponent and the mantissa, 11101 and 00100010000;
5. Converter binary 1110100100010000 to hexadecimal E910.

The detail exponent and resolution of main parameter is summarized as below:

	Exponent	Resolution
Vin	-3	0.125V
Vo	-12	0.244mV
Io	-3	125mA
Temperature	-2	/
Switching frequency	1	2Khz
Time	-1	0.5ms

Supported PMBus Commands

The main PMBus commands described in the PMBus 1.2 specification are supported by the module. Partial PMBus commands are fully supported; Partial PMBus commands have difference with the definition in PMBus 1.2 specification. All the supported PMBus commands are detail summarized in below table.

SUPPORTED PMBUS COMMANDS

The main PMBus commands described in the PMBus 1.2 specification are supported by the module. Partial PMBus commands are fully supported; Partial PMBus commands have difference with the definition in PMBus 1.2 specification. All the supported PMBus commands are detail summarized in below table

Command	Command Code	Command description	Transfer type	Compatible with standard PMBUS or not?	Data Format	Default value	Range limit	Data units	Exponent	Note
OPERATION	0x01	Turn the module on or off by PMBUS command	R/W byte	Refer to below description;	Bit field	0x80	/	/	/	/
ON_OFF_CONFIG	0x02	Configures the combination of primary on/off pin and PMBUS command	R/W byte	Yes	Bit field	0x1D	/	/	/	0x1D (Neg Logic); 0x1F (Pos Logic);
CLEAR_FAULTS	0x03	Clear any fault bits that have been set	Send byte	Yes	/	/	/	/	/	/
WRITE_PROTECT	0x10	Control writing to the PMBUS device.	R/W byte	Yes	/	0x80	/	/	/	The intent of this command is to provide protection against accidental changes.
STORE_DEFAULT_ALL	0x11	Stores operating parameters from RAM to data flash	Send byte	Yes	/	/	/	/	/	The FLASH must be unlocked (referring to Command 0xEC) before sending this command. This command is effective to the parameter of all command in the table except 0xEC
RESTORE_DEFAULT_ALL	0x12	Restores operating parameters from data flash to RAM	Send byte	Yes	/	/	/	/	/	This command can't be issued when the power unit is running.
VOUT_MODE	0x20	Read Vo data format	Read byte	Yes	mode+exp	0x14	/	/	/	/
VOUT_COMMAND	0x21	Read the output voltage	Read word	Yes	Vout Linear	12.2	/	Volts	-12	/
FREQUENCY_SWITCH	0x95	Read the switching frequency	Read word	Yes	Frequency linear	NA		KHz	1	/
VOUT_OV_FAULT_LIMIT	0x40	Set the output overvoltage fault threshold.	R/W word	Yes	Vout Linear	13.5	13~14	V	-12	Must be higher than the value of VOUT_COMMAND and VOUT_OV_WARN_LIMIT;
VOUT_OV_WARN_LIMIT	0x42	Set a threshold causing an output voltage high warning.	R/W word	Yes	Vout Linear	13	12~13	V	-12	Must be the same or less than VOUT_OV_FAULT_LIMIT value
IOUT_OC_FAULT_LIMIT	0x46	Set the output overcurrent fault threshold.	R/W word	Yes	Iout Linear	106	85~106	A	-3	Must be greater than IOUT_OC_WARN_LIMIT value
IOUT_OC_WARN_LIMIT	0x4A	Set a threshold causing an output current high warning.	R/W word	Yes	Iout Linear	100	85~100	A	-3	Must be less than IOUT_OC_FAULT_LIMIT value
OT_FAULT_LIMIT	0x4F	Set the over temperature fault threshold.	R/W word	Yes	TEMP Linear	130	125~135	Deg.C	-2	Must be greater than OT_WARN_LIMIT value

Command	Command Code	Command description	Transfer type	Compatible with standard PMBUS or not?	Data Format	Default value	Range limit	Data units	Exponent	Note
OT_WARN_LIMIT	0x51	Set a threshold causing a temperature high warning.	R/W word	Yes	TEMP Linear	100	80~120	Deg.C	-2	Must be less than OT_FAULT_LIMIT value
VIN_OV_FAULT_LIMIT	0x55	Set the input overvoltage fault threshold.	Read word	Yes	Vin Linear	62		V	-3	/
POWER_GOOD_ON	0x5E	Sets the output voltage at which the bit 3 of STATUS_WORD high byte should be asserted.	Read word	Yes	Vout Linear	11.4		V	-12	Must be greater than POWER_GOOD_OFF value
POWER_GOOD_OFF	0x5F	Sets the output voltage at which the bit 3 of STATUS_WORD high byte should be negated.	Read word	Yes	Vout Linear	11.2	/	V	-12	Must be less than POWER_GOOD_ON value
TON_DELAY	0x60	Sets the time from input voltage condition is received until the output voltage starts to rise	R/W word	Yes	Time Linear	22	22~82	ms	-1	/
TON_RISE	0x61	Sets the time from the output starts to rise until the voltage has entered the regulation band.	Read word	Yes	Time Linear	10	/	ms	-1	/
STATUS_WORD	0x79	Returns the information with a summary of the module's fault/warning	Read word	Refer to below description;	Bit field	/	/	/	/	/
STATUS_VOUT	0x7A	Returns the information of the module's output voltage related fault/warning	Read byte	Refer to below description;	Bit field	/	/	/	/	/
STATUS_IOUT	0x7B	Returns the information of the module's output current related fault/warning	Read byte	Refer to below description;	Bit field	/	/	/	/	/
STATUS_INPUT	0x7C	Returns the information of the module's input over voltage and under voltage fault	Read byte	Refer to below description;	Bit field	/	/	/	/	/
STATUS_TEMPERATURE	0x7D	Returns the information of the module's temperature related fault/warning	Read byte	Refer to below description;	Bit field	/	/	/	/	/
STATUS_CML	0x7E	Returns the information of the module's communication related faults.	Read byte	Refer to below description;	Bit field	/	/	/	/	/
READ_VIN	0x88	Returns the input voltage of the module	Read word	Yes	Vin Linear	/	/	V	-3	/
READ_VOUT	0x8B	Returns the output voltage of the module	Read word	Yes	Vout Linear	/	/	V	-12	/
READ_IOUT	0x8C	Returns the output current of the module	Read word	Yes	Iout Linear	/	/	A	-3	/
READ_TEMPERATURE_1	0x8D	Returns the module's hot spot temperature of the module	Read word	Yes	TEMP Linear	/	/	Deg.C	-2	/
PMBUS_REVISION	0x98	Reads the revision of the PMBus	Read byte	Yes	Bit field	0x22	/	/	/	/
PMBUS_CMD_FLASH_KEY_WRITE	0xEC	Write the key to unlock the Flash before Storing operating parameters from RAM to data flash	R/W	No	/	0xA5A5A5A5		/	/	A data block:7E,15,DC,42 should be send to unlock the FLASH.

OPERATION [0x01]

Bit number	Purpose	Bit Value	Meaning	Default Settings, 0x80
7:	Enable/Disable the module	1	Output is enabled	1
		0	Output is disabled	
6:0	Reserved			0000000

ON_OFF_CONFIG [0x02]

Bit number	Purpose	Bit Value	Meaning	Default Settings, 0x1D (negative) /0x1F (positive)
7:5	Reserved			000
4	Controls how the unit responds to the primary on/off pin and the OPERATION command;	1	Module does not power up until commanded by the primary ON/OFF pin and the OPERATION	1
		0	Module power up at any time regardless of the state of the primary ON/OFF pin and the OPERATION	
3	Controls how the unit responds to the OPERATION command	1	Module responds to the 7 bit in the OPERATION	1
		0	Module ignores the 7 bit in the OPERATION	
2	Controls how the unit responds to the primary on/off pin	1	Module requires the primary ON/OFF pin to be asserted to start the unit	1
		0	Module ignores the state of the primary ON/OFF pin	
1	Control logic of primary on/off pin	1	Positive Logic	0, negative; 1, positive.
		0	Negative Logic	
0	Unit turn off delay time control	1	Shut down the module with 0 delay cycle	1

STATUS_WORD [0x79]

High byte

Bit number	Purpose	Bit Value	Meaning
7	An output over voltage fault or warning	1	Occurred
		0	No Occurred
6	An output over current fault or warning	1	Occurred
		0	No Occurred
5	An input voltage fault, including over voltage and undervoltage	1	Occurred
		0	No Occurred
4	Reserved		
3	Power_Good	1	is negated
		0	ok
2:0	Reserved		

Low byte

Bit number	Purpose	Bit Value	Meaning
7	Reserved		
6	OFF (The unit is not providing power to the output, regardless of the reason)	1	Occurred
		0	No Occurred
5	An output over voltage fault	1	Occurred
		0	No Occurred
4	An output over current fault	1	Occurred
		0	No Occurred
3	An input under voltage fault	1	Occurred
		0	No Occurred
2	A temperature fault or warning	1	Occurred
		0	No Occurred
1	CML (A communications, memory or logic fault)	1	Occurred;
		0	No Occurred
0	Reserved		

STATUS_VOUT [0x7A]

Bit number	Purpose	Bit Value	Meaning
7	Output over voltage fault	1	Occurred;
		0	No Occurred
6	Output over voltage warning	1	Occurred;
		0	No Occurred
5:0	Reserved		

STATUS_IOUT [0x7B]

Bit number	Purpose	Bit Value	Meaning
7	Output over current fault	1	Occurred;
		0	No Occurred
6	Reserved		
5	Output over current warning	1	Occurred;
		0	No Occurred
4:0	Reserved		

STATUS_INPUT [0x7C]

Bit number	Purpose	Bit Value	Meaning
7	Input over voltage fault	1	Occurred;
		0	No Occurred
6: 5	Reserved		
4	Input under voltage fault	1	Occurred;
		0	No Occurred
3:0	Reserved		

STATUS_TEMPERATURE [0x7D]

Bit number	Purpose	Bit Value	Meaning
7	Over temperature fault	1	Occurred;
		0	No Occurred
6	Over temperature warning	1	Occurred;
		0	No Occurred
5:0	Reserved		

STATUS_CML [0x7E]

Bit number	Purpose	Bit Value	Meaning
7	Invalid/Unsupported Command Received	1	Occurred;
		0	No Occurred
6	Invalid/Unsupported Data Received	1	Occurred;
		0	No Occurred
5	Packet Error Check Failed	1	Occurred;
		0	No Occurred
4:0	Reserved		

Thermal Testing Setup

Thermal management is an important part of the system design. To ensure proper, reliable operation, sufficient cooling of the power module is needed over the entire temperature range of the module. Convection cooling is usually the dominant mode of heat transfer.

Hence, the choice of equipment to characterize the thermal performance of the power module is a wind tunnel.

Delta's DC/DC power modules are characterized in heated vertical wind tunnels that simulate the thermal environments encountered in most electronics equipment. This type of equipment commonly uses vertically mounted circuit cards in cabinet racks in which the power modules are mounted.

The following figure shows the wind tunnel characterization setup. The power module is mounted on a 185mmX185mm, 105µm (3Oz), 6 layers' test PWB and is vertically positioned within the wind tunnel. The space between the neighboring PWB and the top of the power module is constantly kept at 6.35mm (0.25").

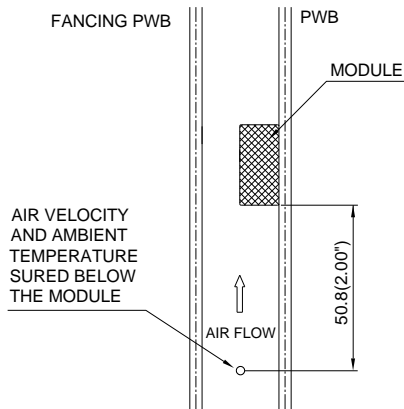

Note: Wind Tunnel Test Setup Figure Dimensions are in millimeters and (Inches)

Figure 16: Wind Tunnel Test Setup

Thermal Derating

Heat can be removed by increasing airflow over the module. To enhance system reliability, the power module should always be operated below the maximum operating temperature. If the temperature exceeds the maximum module temperature, reliability of the unit may be affected.

Thermal Curves (With Heat-spreader)

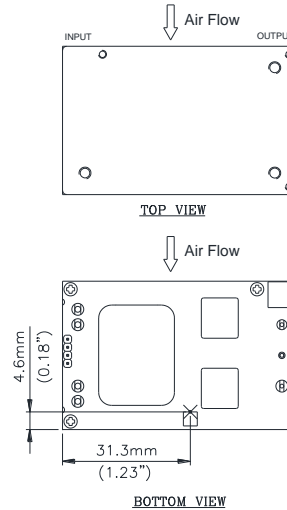

Figure 17: Hot spot 1 temperature measurement location
The allowed maximum hot spot 1 temperature is defined at 124 °C.

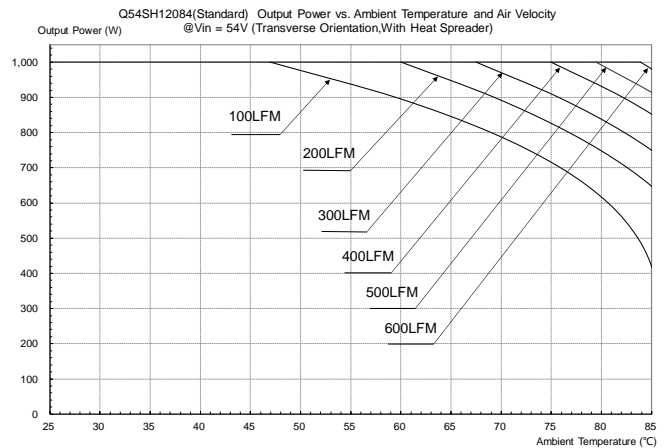

Figure 18: Output Power vs. Ambient Temperature and Air Velocity @ Vin = 54V (Transverse Orientation, Airflow from Vin+ to Vin-, With Heat-spreader)

Thermal Curves (With 0.5" Height Heat Sink QTL050A)

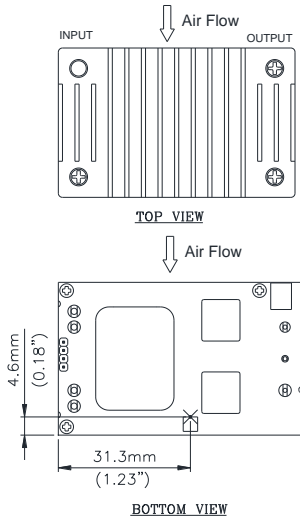

Figure 19: Hot spot 2 temperature measurement location
The allowed maximum hot spot 2 temperature is defined at 124 °C.

Thermal Curves (With 0.5" Height Heat Sink QLL050A)

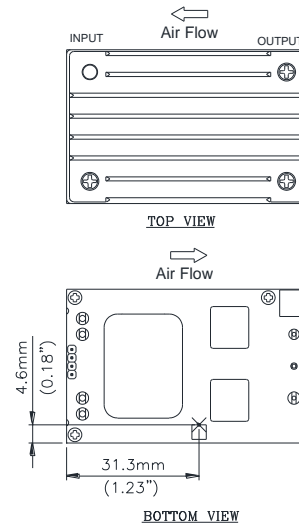

Figure 21: Hot spot 3 temperature measurement location
The allowed maximum hot spot 3 temperature is defined at 124 °C.

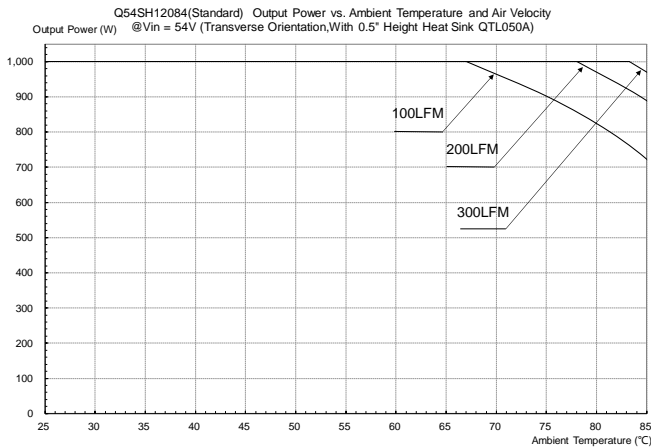

Figure 20: Output Power vs. Ambient Temperature and Air Velocity @ $V_{in} = 54V$ (Transverse Orientation, Airflow from V_{in+} to V_{in-} , With 0.5" Height Heat Sink QTL050A)

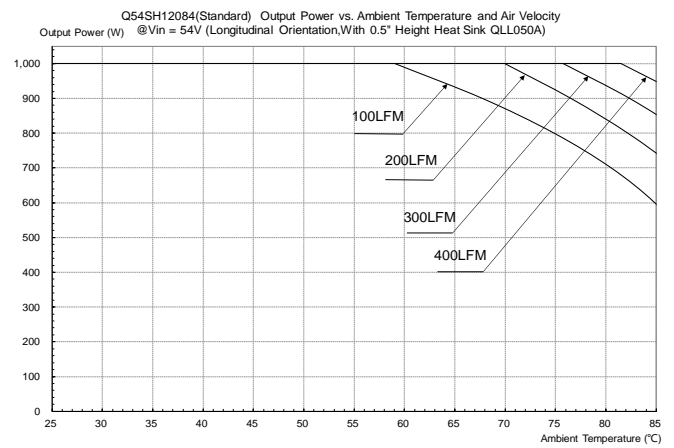
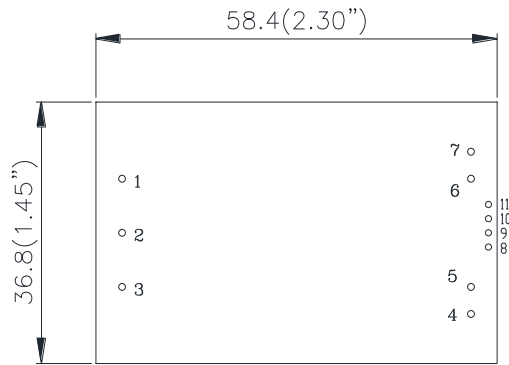
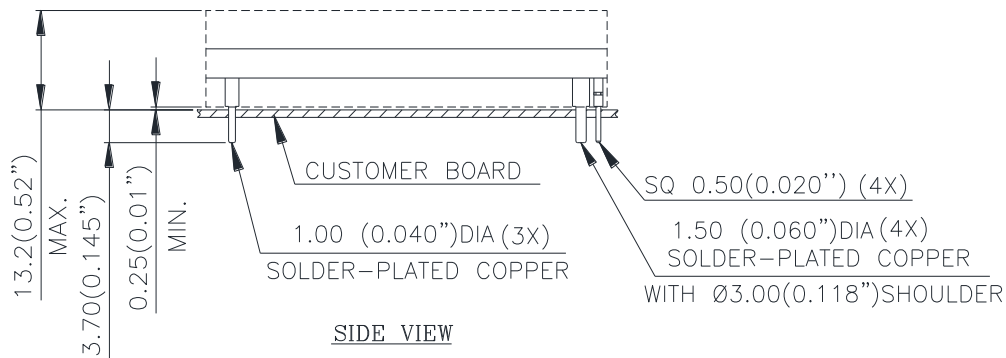

Figure 22: Output Power vs. Ambient Temperature and Air Velocity @ $V_{in} = 54V$ (Longitudinal Orientation, Airflow from V_{out} to V_{in} , With 0.5" Height Heat Sink QLL050A)

Mechanical Drawing (Without Heat-spreader)



TOP VIEW



SIDE VIEW

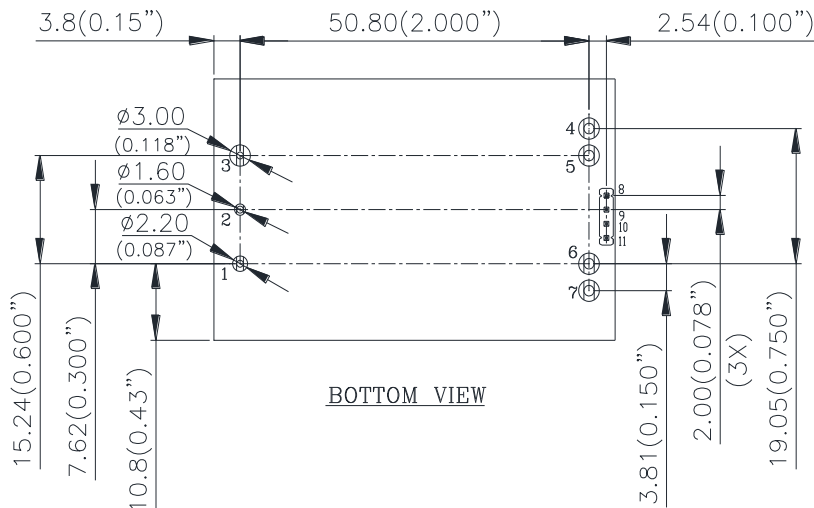

BOTTOM VIEW

Pin#	Function
1	Vin(+)
2	ON/OFF
3	Vin(-)
4	Vout(-)
5	Vout(-)
6	Vout(+)
7	Vout(+)
8	Data
9	Alert
10	Clock
11	Addr

NOTES:
 DIMENSIONS ARE IN MILLIMETERS AND (INCHES)
 TOLERANCES: X.Xmm±0.5mm(X.XX in.±0.02 in.)
 X.XXmm±0.25mm(X.XXX in.±0.010 in.)

Mechanical Drawing (With Heat-spreader)

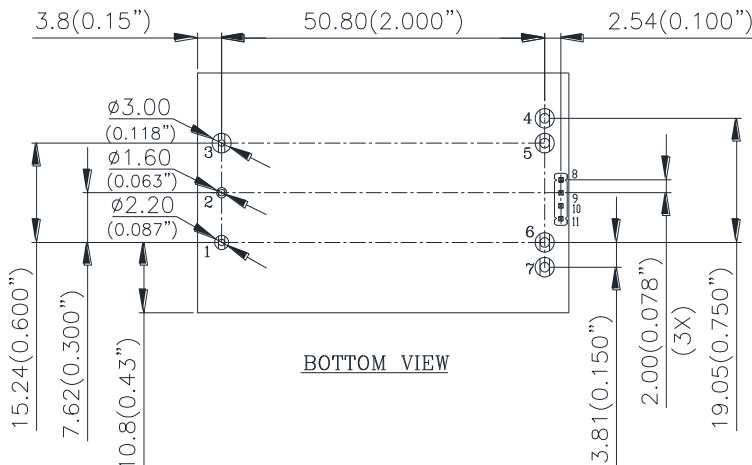
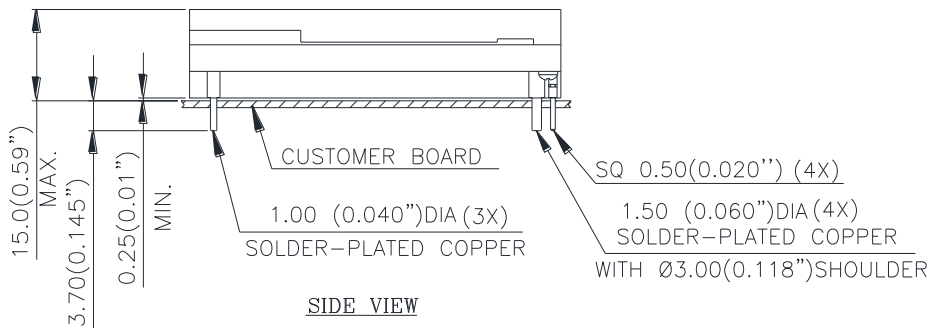
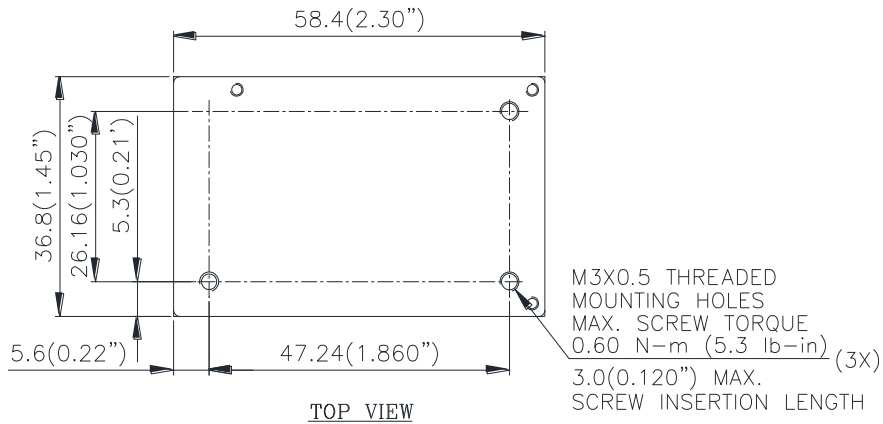

Pin#	Function
1	Vin(+)
2	ON/OFF
3	Vin(-)
4	Vout(-)
5	Vout(-)
6	Vout(+)
7	Vout(+)
8	Data
9	Alert
10	Clock
11	Addr

NOTES:
 DIMENSIONS ARE IN MILLIMETERS AND (INCHES)
 TOLERANCES: X.Xmm±0.5mm(X.XX in.±0.02 in.)
 X.XXmm±0.25mm(X.XXX in.±0.010 in.)

Mechanical Drawing (With Heat-spreader and Heatsink: QLL050A)

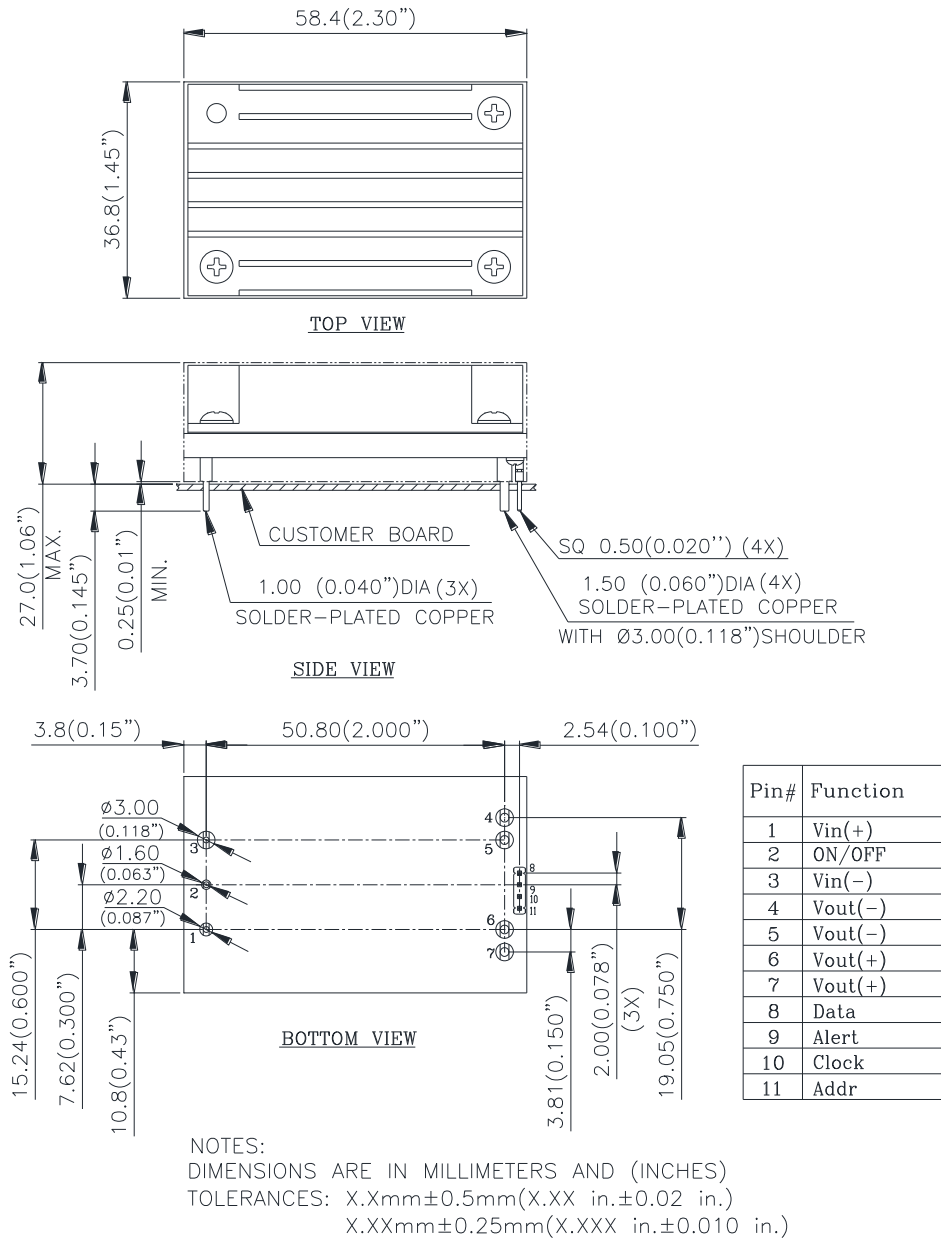

Pin Specification:

Pins 1-3
 Pins 4-7
 Pins 8~11

1.00mm (0.040") diameter (All pins are copper with matte Tin plating over Nickel under plating)
 1.50mm (0.059") diameter (All pins are copper with matte Tin plating over Nickel under plating)
 Digital pins; Square 0.50mm (0.020"); copper with golden flash plating

Recommended Pad Layout

RECOMMENDED PWB LAYOUT

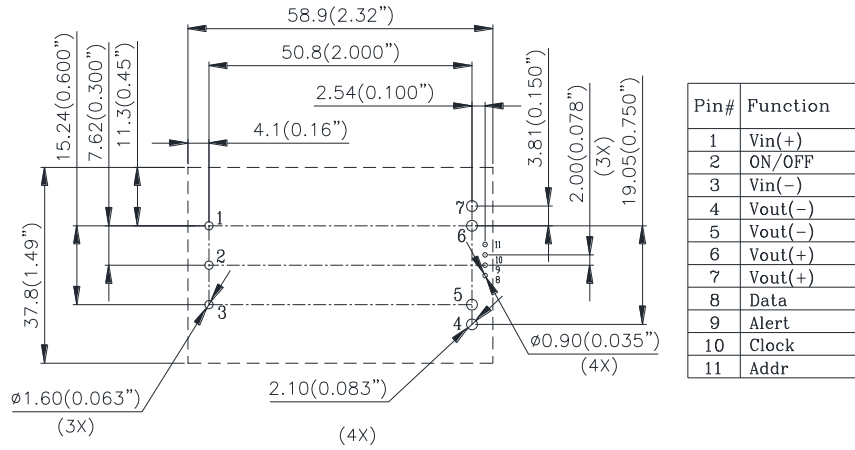

Pin#	Function
1	Vin(+)
2	ON/OFF
3	Vin(-)
4	Vout(-)
5	Vout(-)
6	Vout(+)
7	Vout(+)
8	Data
9	Alert
10	Clock
11	Addr

NOTES:
 DIMENSIONS ARE IN MILLIMETERS AND (INCHES)
 TOLERANCES: X.Xmm±0.5mm(X.XX in.±0.02 in.)
 X.XXmm±0.25mm(X.XXX in.±0.010 in.)

Soldering Method

Generally, as the most common mass soldering method for the solder attachment, wave soldering is used for through-hole power modules and reflow soldering is used for surface-mount ones. Delta recommended soldering methods and process parameters are provided in this document for solder attachment of power modules onto system board. SAC305 is the suggested lead-free solder alloy for all soldering methods.

Reflow soldering is not a suggested method for through-hole power modules due to many process and reliability concerns. If you have this kind of application requirement, please contact Delta sales or FAE for further confirmation.

Wave Soldering (Lead-free)

Delta's power modules are designed to be compatible with single-wave or dual wave soldering. The suggested soldering process must keep the power module's internal temperature below the critical temperature of 217°C continuously. The recommended wave-soldering profile is shown in following figure.

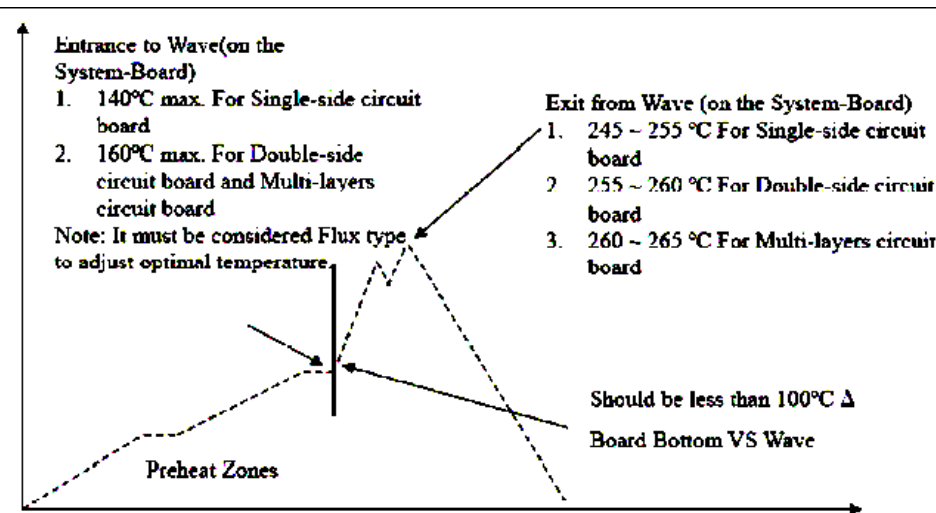

Recommended Temperature Profile for Lead-free Wave Soldering

Note: The temperature is measured on solder joint of pins of power module.

The typical recommended (for double-side circuit board) preheat temperature is 115+/-10°C on the top side (component side) of the circuit board. The circuit-board bottom-side preheat temperature is typically recommended to be greater than 135°C and preferably within 100°C of the solder-wave temperature. A maximum recommended preheat up rate is 3°C/s. A maximum recommended solder pot temperature is 255+/-5°C with solder-wave dwell time of 3~6 seconds. The cooling down rate is typically recommended to be 6°C/s maximum.

Hand Soldering (Lead Free)

Hand soldering is the least preferred method because the amount of solder applied, the time the soldering iron is held on the joint, the temperature of the iron, and the temperature of the solder joint are variable. The recommended hand soldering guideline is listed in following table. The suggested soldering process must keep the power module's internal temperature below the critical temperature of 217°C continuously.

Hand-Soldering Guideline

Parameter	Single-side Circuit Board	Double-side Circuit Board	Multi-layers Circuit Board
Soldering Iron Wattage	90	90	90
Tip Temperature	385+/-10°C	420+/-10°C	420+/-10°C
Soldering Time	2 ~ 6 seconds	4 ~ 10 seconds	4 ~ 10 seconds



PART NUMBERING SYSTEM

Q	54	S	H	120	84	N	N	D ^{*note}	H
Type of Product	Input Voltage	Number of Outputs	Product Series	Output Voltage	Output Current	ON/OFF Logic	Pin Length / Type	Pin Assignment	Option Code
Q - Quarter Brick	54 - 40~60V	S - Single	H - Series number	120 - 11.8V	84 - 84.8A	P - Positive N - Negative	R - 0.170" N - 0.145" K - 0.110"	D - Digital pins A - Analog pins	H - heat-spreader version F - with heat-spreader and QLL050A heatsink A - without heat-spreader

Note for mechanical pins option:

1. D - Digital pins*: with digital pin 8~11.
2. A - Analog pins*: without digital pin 8~11

RECOMMENDED PART NUMBER

Model Name	Input	Output	Peak Eff.
Q54SH12084NNDH	40V~60V	27A 11.8V	84.8A 97.3%
Q54SH12084NNDA	40V~60V	27A 11.8V	84.8A 97.3%

Default remote On/Off logic is negative.

Please contact with Delta sales/FAE for different optional functions.

CONTACT US:

Website: www.deltaww.com/dcdc

USA:

Telephone:
East Coast: 978-656-3993
West Coast: 510-668-5100
Fax: (978) 656 3964

Email: dcdc@deltaww.com

Europe:

Telephone: +31-20-655-0967
Fax: +31-20-655-0999

Asia & the rest of world:

Telephone: +886 3 4526107
Ext. 6220~6226
Fax: +886 3 4513485

WARRANTY

Delta offers a two (2) year limited warranty. Complete warranty information is listed on our web site or is available upon request from Delta.

Information furnished by Delta is believed to be accurate and reliable. However, no responsibility is assumed by Delta for its use, nor for any infringements of patents or other rights of third parties, which may result from its use. No license is granted by implication or otherwise under any patent or patent rights of Delta. Delta reserves the right to revise these specifications.