



Grid-tie Transformerless Solar Inverter

M100_210
Operation and Installation Manual

English 1

繁體中文 83

www.deltaww.com

 **DELTA**
Smarter. Greener. Together.

Contents

- 1 Safety 8**
 - 1.1 Information of the Inverter 8
 - 1.1.1 Legal Provisions 8
 - 1.1.2 Target Group 8
 - 1.2 General Safety 9
 - 1.2.1 Condition of Use 9
 - 1.2.2 Symbols 10
- 2 Introduction 12**
 - 2.1 Valid Model 12
 - 2.2 Product Overview 13
- 3 Installation 17**
 - 3.1 Unboxing & Review 17
 - 3.2 Mechanical Installation 19
 - 3.2.1 Wall mount 20
 - 3.2.2 Ground Mount (optional) 25
 - 3.3 Route the cables to M100_210 27
 - 3.4 Electrical Installation for AC Wiring 29
 - 3.4.1 AC Grid Types and Connections 29
 - 3.4.2 Required Protective Devices 30
 - 3.4.3 Preparation for AC Wires Connection 30
 - 3.4.4 Preparation for PE cables Connection 30
 - 3.4.5 Install PE Cables 31
 - 3.4.6 AC Wiring 33
 - 3.5 Electrical Installation for DC Wiring 34
 - 3.5.1 Preparation for DC Wires Connection 34
 - 3.5.2 Install DC cables 35
 - 3.6 SUB_1G Antenna (optional) 38
 - 3.7 Communication 41
 - 3.7.1 RS-485 Connection 43
 - 3.7.2 EPO Function & Digital Input 45
 - 3.7.3 Dry Contact Connection 46

- 4 Commissioning 47**
 - 4.1 Display Operation Introduction 47
 - 4.2 Auto ID Commission 48
 - 4.2.1 Commission Setting (DSS) 48
 - 4.2.2 Scan inverter 49
 - 4.2.3 Set ID 50
 - 4.2.4 Set Country 51
 - 4.2.5 Synchronize time 52
 - 4.3 Delta Function Setting 53
- 5 Maintenance 54**
 - 5.1 Open and Close the Door 54
 - 5.1.1 Disconnect M100_210 from Voltage Sources 54
 - 5.1.2 Open Door 54
 - 5.1.3 Close Door 57
 - 5.2 Replacement of Surge Protection Devices (SPD) 58
 - 5.2.1 Removing SPD 59
 - 5.2.1 Installing SPD 59
 - 5.3 Smart Fans Replacement and Filter Cleaning 62
 - 5.3.1 Location of failure fan 63
 - 5.3.2 Power Module (PM) Fan Tray 63
 - 5.3.3 Internal Fan 1 65
 - 5.3.4 Internal Fan 2 67
 - 5.4 De-Commissioning 69
- 6 Error Message and Trouble Shooting 70**
 - 6.1 Error Codes (Field Fault) 70
 - 6.2 Fault Codes (Inverter Fault) 71
 - 6.3 Warning Codes (Field Warning) 73
 - 6.4 Warning Codes (Inverter Warning) 73
- 7 Technical Information 74**
- Appendix: Assembly Note 80**

Figure

- Figure 2-1: Components 13
- Figure 2-2: Overview 14
- Figure 2-3: Rating label 15
- Figure 2-4: Layout 16
- Figure 3-1: The step to unpackage the inverter 17
- Figure 3-2: Hand hold position for lifting 18
- Figure 3-3: Permitted mounting positions 19
- Figure 3-4: Inverter dimensions 20
- Figure 3-5: Mounting bracket dimensions 21
- Figure 3-6: Positions of mounting screws 22
- Figure 3-7: Required mounting clearances 23
- Figure 3-8: Separation distance of plural inverters 24
- Figure 3-9: Lock the grounded brackets to feet 25
- Figure 3-10: To secure inverter grounded brackets to ground-mounting base 26
- Figure 3-11: Cable routing 27
- Figure 3-12: AC side metal conduit installation suggestion 28
- Figure 3-13: Location for internal PE terminal 31
- Figure 3-14: Mount the equipment grounding 32
- Figure 3-15: Location for AC terminal 33
- Figure 3-16: DC Gland with multiple inlet 35
- Figure 3-17: Slide the protective cover 35
- Figure 3-18: wiring of DC busbar (for 1 PV combiner box) 36
- Figure 3-19: wiring of DC busbar (for 2 PV combiner box) 37
- Figure 3-20: Installation of antenna 38
- Figure 3-21: Attention of installing antenna 39
- Figure 3-22: Install antenna bracket 40
- Figure 3-23: Communication Module Layout 41
- Figure 3-24: Location and access to Communication Module 42
- Figure 3-25: Multiinverter connection illustration 44
- Figure 3-26: EPO function terminal block 45
- Figure 3-27: Dry Contact connection 46
- Figure 4-1: Front Panel Display 47
- Figure 4-2: DSS Commission setting 48
- Figure 4-3: Steps of scanning inverters 49
- Figure 4-4: Steps of ID setting 50
- Figure 4-5: Steps of country setting 51
- Figure 4-6: Steps of time synchronization 52

Figure 5-1: Open and close the door 55

Figure 5-2: To secure door by hexagon driver 56

Figure 5-3: Remove the door 57

Figure 5-4: SPD modules 58

Figure 5-5: Remove the protective cover 60

Figure 5-6: Remove sensing cable and screws 61

Figure 5-7: The corresponding fan location to the fan fail code on DSS 63

Figure 5-8: Disassembling fan tray from PM chassis 64

Figure 5-9: Internal fan 1 location & remove the shield cover 65

Figure 5-10: Take off the internal fan 1 66

Figure 5-11: Replace with a new fan 66

Figure 5-12: Internal fan 2 location & remove the shield cover 67

Figure 5-13: Take off the internal Fan 2 68

Figure 5-14: Replace with a new fan 68

Figure 7-1: Efficiency Curve 76

Figure 7-2: Power Derating Curve with Ambient Temperature (400 Vac) 77

Figure 7-3: Power Derating Curve with Ambient Temperature (380 Vac) 77

Figure 7-4: Power De-rating Curves with PV Voltage 78

Figure 7-5: Max. Output Power Capability 79

Table

Table 2-1: Packing list 13

Table 2-2: Overview description 14

Table 2-3: Rating label explanation 15

Table 2-4: Layout description 16

Table 3-1: Recommended AC circuit breaker rating 29

Table 3-2: Cable size comparison table 35

Table 3-3: RS-485 Terminal block wiring 43

Table 3-4: Bus Termination switch settings 44

Table 3-5: Definition of digital input & EPO function 45

Table 4-1: LED indicator 47

Table 4-2: LED COMM indicator 47

Table 6-1A: Error Codes (Field Fault) and Messages 70

Table 6-2A: Fault Codes (inverter fault) & Messages 71

Table 6-2B: Fault Codes (inverter fault) & Messages 72

Table 6-3A: Warning Codes (Field warning) & Messages 73

Table 6-4A: Warning Codes (inverter warning) & Messages 73

Table 7-1A: Specifications 74

Table 7-1B: Specifications 75

Appendix-1: Assembly Note-1 80

Appendix-2: Assembly Note-2 81

Appendix-3: Assembly Note-3 82

1 Safety

1.1 Information of the Inverter

1.1.1 Legal Provisions

Copyright – DELTA ELECTRONICS, INC. - All rights reserved.

This manual accompanies our product for use by the end users. The technical instructions and illustrations contained in this manual are to be treated as confidential and no part may be reproduced without the prior written permission of DELTA ELECTRONICS, INC. Service engineers and end users may not divulge the information contained herein or use this manual for purpose other than those strictly connected with correct use of the product. All information and specifications are subject to change without notice.

DELTA ELECTRONICS, INC. shall have no obligation to either personal injury and property damage claims hereinafter with respect to any actions -- (a) the product has been installed and/or repaired improperly; (b) the product has been misused without following the instructions on this user manual; (c) the product has failed due to incorrect unpacking.

1.1.2 Target Group

This manual is prepared for use by well-trained technician for installing, commissioning, operation, and maintenance. The technician must have the following basic and advanced skills:

- Knowledge of the fundamentals of electricity, wiring, electrical components and electrical schematic symbols.
- Knowledge of how a solar inverter works and is operated.
- Training in the installation and commissioning of electrical devices and installations.
- Training in how to deal with the dangers and risks associated with installing and using electrical devices and installations.
- Compliance with this manual and all safety information.

1.2 General Safety

IMPORTANT SAFETY INSTRUCTIONS : SAVE THESE INSTRUCTIONS !



- Please read these instructions carefully and save them for later use.

To prevent personal injury and/or property damage, and also to ensure long term operation of the solar inverter, it is imperative this section be read carefully and all the safety instructions understood before using this inverter.

This user manual provides important instructions for Delta grid-tie transformerless solar inverter. The product is designed, tested, verified, and certified according to international safety requirements, certifications, and standards but precautions must be observed when installing and operating the product.

This product is suitable for both indoor and outdoor use.

ATTENTION : NO GALVANIC ISOLATION



- The design of this inverter is transformerless. There is no isolation transformer between the AC and DC sides, i.e., the product does not require galvanic isolation. In order to function properly, any PV array connected must have its PV circuits isolated from ground, i.e., do not bond either side of the array to ground! If a grounded PV array is connected to the inverter, the error message INSULATION (E34) will appear on the display.

- It is prohibited to reference the L1, L2, L3 or N terminal to ground; to do so will damage the inverter and void the product warranty.

1.2.1 Condition of Use

- M100_210 is a transformerless solar inverter with 1 MPP tracking input, which converts the variable direct current generated by the solar array into a utility frequency grid-compliant balanced three-phase AC current and feeds it into the utility grid.
- The Photovoltaic modules used must be compatible with the inverter. PV modules with a high parasitic capacitance to ground may only be utilized if the capacitive coupling does not exceed 10 μ F.
- The inverter should be operated in countries which are approved by DELTA and the grid operator.

1.2.2 Symbols

The symbols in this manual have defined by the severity of the danger. Ensure the safety during the product installation or the system maintenance, please follow the instructions of the manual to operate the product.

DANGER!



- This warning indicates an immediate hazard which will lead to death or serious injury.

WARNING !



- This warning indicates a hazardous condition which may lead to death or serious injury.

CAUTION !



- This warning indicates a hazardous condition which may lead to minor injury.

ATTENTION



- This warning indicates a condition of potential damage to property and/or the environment.

INFORMATION

- An exclamation mark enclosed in a double circle indicates additional important information is contained in the following section and the user should follow the instructions to prevent any hazards.

DANGER : ELECTRICAL HAZARD!!

- This warning indicates an immediate electrical hazard that unheeded can lead to death or serious injury.

CAUTION : HOT SURFACES, DO NOT TOUCH!

- This warning indicates a potential burn hazard.
- Use care when touching surfaces when operating the product.
- Do not perform any task until the product cools down sufficiently.



- This icon indicates that a prescribed time delay must elapse before engaging in an indicated action.
- Patientez le délai requis avant d'entreprendre l'action indiquée.



- This symbol indicates the location of an equipment grounding conductor (EGC) terminal.

2 Introduction

M100_210 transformerless 3Ø PV inverters are designed to enable the highest levels of efficiency and provide longest operating life by use of state-of-the-art high frequency and low EMI switchmode technology. It is suitable for outdoor use.

ATTENTION : NO GALVANIC ISOLATION



- This product utilizes a transformerless design, and is not provisioned with an isolation transformer, and therefore has no galvanic isolation between the DC and AC sides.
PV array circuits connected must be floating with respect to ground, i.e., must not be referenced (bonded) to ground.
If grounded PV arrays are connected to the inverter, the inverter will not connect to the grid and the error message INSULATION (E34) will appear.
- It is prohibited to connect terminals L1, L2, L3 or N to ground.

ATTENTION : Intended for Industrial Environments



- M100_210 has been tested and found to comply with the limits for IEC 62910 Class A which is designed to provide reasonable protection against harmful interference in the commercial environment operation.
- This device generates radiofrequency energy, please accord this manual to install and use.
- Operation in a residential area could cause harmful interference.

2.1 Valid Model

The user manual is valid for the following device types:

- M100_210

This user manual must be followed during installation, operation, and maintenance.

DELTA reserves the right to make modifications to the content and technical data in this user manual without prior notice.

2.2 Product Overview

The components is shown as **Figure 2-1**.

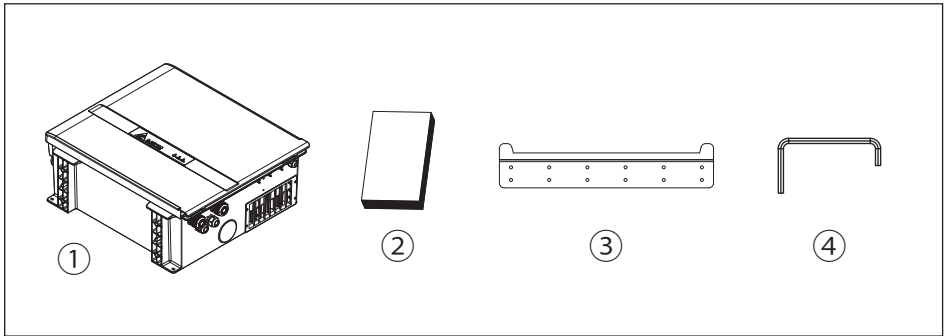

Figure 2-1: Components

Table 2-1: Packing list

M100_210			
	Object	Qty	Description
1	Delta Solar Inverter	1 pc	Solar inverter
2	User Manual	1 pc	Important instructions for solar inverter. Safety instructions should be followed during installation and maintenance.
3	Mounting Bracket	1 pc	Wall mounting bracket (Material: Aluminum/Thickness: 3mm)
4	Hexagon Driver (Installed on latch lock cover)	1 pc	Keep the door being open. Can unscrew the latch lock cover screw.

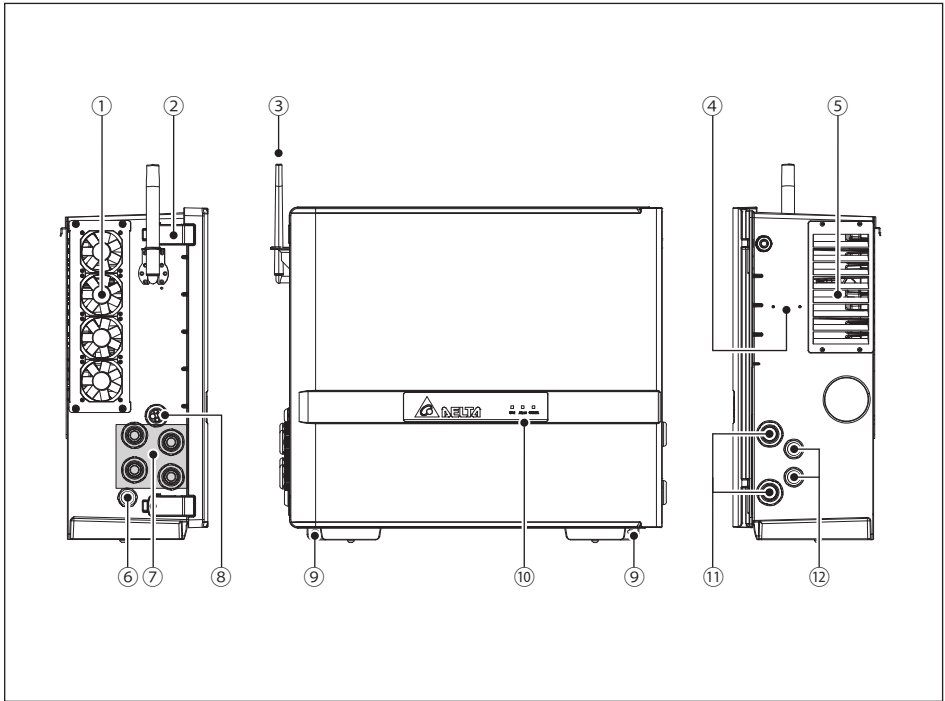

Figure 2-2: Overview

Table 2-2: Overview description

NO.	Component	NO.	Component	NO.	Component
1	External fans	2	Toggle Latch	3	SUB_1G antenna*
4	Port for Wi-Fi antenna*	5	Air cooling outlet	6	M25 gland for PE wiring
7	4x M40 glands for AC Output	8	Cable gland for communication wiring	9	External grounding point
10	LED Indicators	11	2x M40 glands for DC Input	12	2x M25 glands for DC Input

* SUB_1G / Wi-Fi antenna is an optional part, please contact the customer service center for the detail.

Figure 2-3, below, shows the certification and rating label.
Table 2-3, defines the symbol markings on this label.















<p>Model / 型號 M100_210 Solar Inverter / 太陽能變流器 P/N: RP1104M2101100</p>  <p>DC Input / 直流輸入 Max. Input Voltage / 最大輸入電壓 1000 Vd.c. MPP Voltage Range / MPP電壓範圍 590 ~ 860 Vd.c. Max. Input Current / 最大輸入電流 185 Ad.c. Max. Short Circuit Current / 最大短路電流 250 Ad.c.</p> <p>AC Output / 交流輸出 Nominal Output Voltage / 額定工作電壓 400 / 380 Va.c. Nominal Output Frequency / 額定工作頻率 50 / 60 Hz Connection Type / 連接形式 3Ø3W / 3Ø4W, PE Max. Continuous Output Current / 最大輸出電流 160 Aa.c. Rated Continuous Output Power / 額定輸出功率 100000 W Max. Apparent Output Power / 最大視在功率 110000 VA Power Factor / 功率因數 0.8 lead ~ 0.8 lag</p> <p>Protection Class / 保護等級 I Over Voltage Category / 過電壓類別 III (AC), II (DC) Ingress Protection / 防護等級 IP66 Operating Temperature Range / 操作溫度範圍 -25 ~ +40°C Non-isolated inverter 非隔離型變流器</p> <p>Manufacturing location: Made in China No. 1688 Jiangling East Road, Wujiang Economic Development Zone Suzhou City, 215200 Jiangsu Province, P.R. China</p> <p>Authorized representative Delta Electronics (Netherlands) B.V. Zandvliet 15, 2132 MZ Hoofddorp, The Netherlands</p>  	<p>Model / 型號 M100_210 Solar Inverter / 太陽能變流器 P/N: RP1104M2101100</p>  <p>DC Input / 直流輸入 Max. Input Voltage / 最大輸入電壓 1000 Vd.c. MPP Voltage Range / MPP電壓範圍 590 ~ 860 Vd.c. Max. Input Current / 最大輸入電流 185 Ad.c. Max. Short Circuit Current / 最大短路電流 250 Ad.c.</p> <p>AC Output / 交流輸出 Nominal Output Voltage / 額定工作電壓 400 / 380 Va.c. Nominal Output Frequency / 額定工作頻率 50 / 60 Hz Connection Type / 連接形式 3Ø3W / 3Ø4W, PE Max. Continuous Output Current / 最大輸出電流 160 Aa.c. Rated Continuous Output Power / 額定輸出功率 100000 W Max. Apparent Output Power / 最大視在功率 110000 VA Power Factor / 功率因數 0.8 lead ~ 0.8 lag</p> <p>Protection Class / 保護等級 I Over Voltage Category / 過電壓類別 III (AC), II (DC) Ingress Protection / 防護等級 IP66 Operating Temperature Range / 操作溫度範圍 -25 ~ +40°C Non-isolated inverter 非隔離型變流器</p> <p>Manufacturing location: Made in China No. 1688 Jiangling East Road, Wujiang Economic Development Zone Suzhou City, 215200 Jiangsu Province, P.R. China</p> <p>Authorized representative Delta Electronics (Netherlands) B.V. Zandvliet 15, 2132 MZ Hoofddorp, The Netherlands</p>  	<p>Model / 型號 M100_210 Solar Inverter / 太陽能變流器 P/N: RP1104M211100</p>  <p>DC Input / 直流輸入 Max. Input Voltage / 最大輸入電壓 1000 Vd.c. MPP Voltage Range / MPP電壓範圍 590 ~ 860 Vd.c. Max. Input Current / 最大輸入電流 185 Ad.c. Max. Short Circuit Current / 最大短路電流 250 Ad.c.</p> <p>AC Output / 交流輸出 Nominal Output Voltage / 額定工作電壓 400 / 380 Va.c. Nominal Output Frequency / 額定工作頻率 50 / 60 Hz Connection Type / 連接形式 3Ø3W / 3Ø4W, PE Max. Continuous Output Current / 最大輸出電流 160 Aa.c. Rated Continuous Output Power / 額定輸出功率 100000 W Max. Apparent Output Power / 最大視在功率 110000 VA Power Factor / 功率因數 0.8 lead ~ 0.8 lag</p> <p>Protection Class / 保護等級 I Over Voltage Category / 過電壓類別 III (AC), II (DC) Ingress Protection / 防護等級 IP66 Operating Temperature Range / 操作溫度範圍 -25 ~ +40°C Non-isolated inverter 非隔離型變流器</p> <p>Manufacturing location: Made in China No. 1688 Jiangling East Road, Wujiang Economic Development Zone Suzhou City, 215200 Jiangsu Province, P.R. China</p> <p>Authorized representative Delta Electronics (Netherlands) B.V. Zandvliet 15, 2132 MZ Hoofddorp, The Netherlands</p>  
---	---	--

Figure 2-3: Rating label

Table 2-3: Rating label explanation

Symbol	Definition	
 <p>60 seconds</p>	<p>Danger to life through electric shock Potentially fatal voltage is applied to the inverter during operation. This voltage persists even 60 seconds after disconnection of the power supply. Never open the inverter. The inverter contains no components that must be maintained or repaired by the operator or installer. Opening the housing will void the warranty.</p>	
	<p>This inverter is not separated from the grid with a transformer.</p>	 <p>Before working with the inverter, you must read the supplied manual and follow the instructions contained therein.</p>
	<p>The housing of the inverter must be grounded if this is required by local regulations.</p>	 <p>WEEE marking The inverter must not be disposed of as standard household waste, but in accordance with the applicable electronic waste disposal regulations of your country or region.</p>

In the following pages, **Figure 2-4** illustrate the general layout of the M100_210 chassis and wiring area.

The wiring area includes terminals for connection of the output (AC) wiring, surge protection devices (SPD).

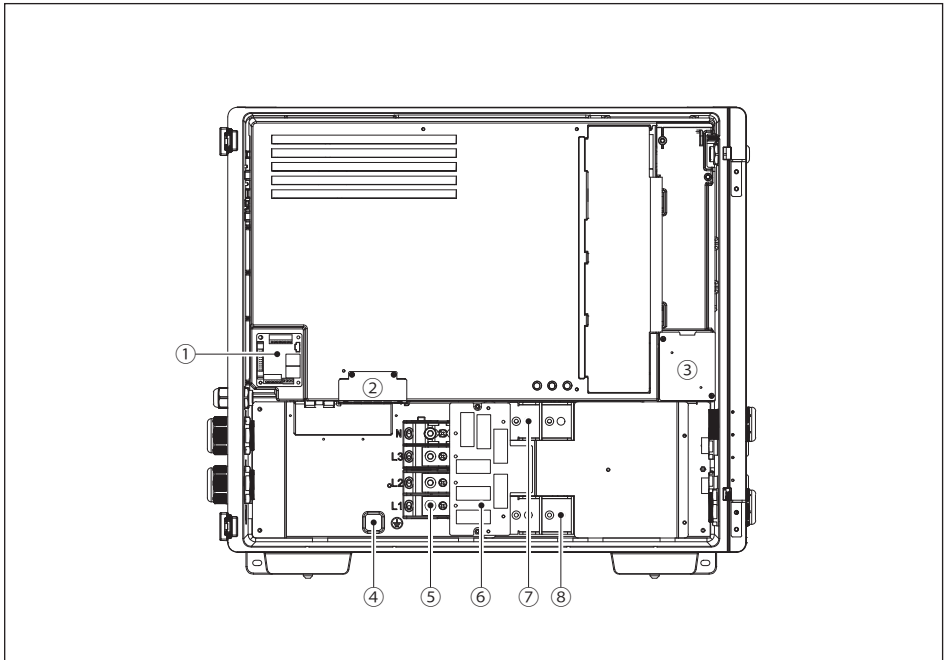

Figure 2-4: layout

Table 2-4: layout description

NO.	Component	NO.	Component	NO.	Component
1	Communication module	2	Internal fan 2	3	Internal fan 1
4	Internal grounding point	5	AC terminal	6	Type II SPD
7	DC out busbar (-)	8	DC out busbar (+)		

3 Installation

The chapter contains instructions for

- (1) Mechanical installation
- (2) Electrical Installation
- (3) Communication setup

3.1 Unboxing & Review

Unpacking the M100_210, please follow the order of **Figure 3-1**.

It could be transported by 2 people (**Figure 3-2**).

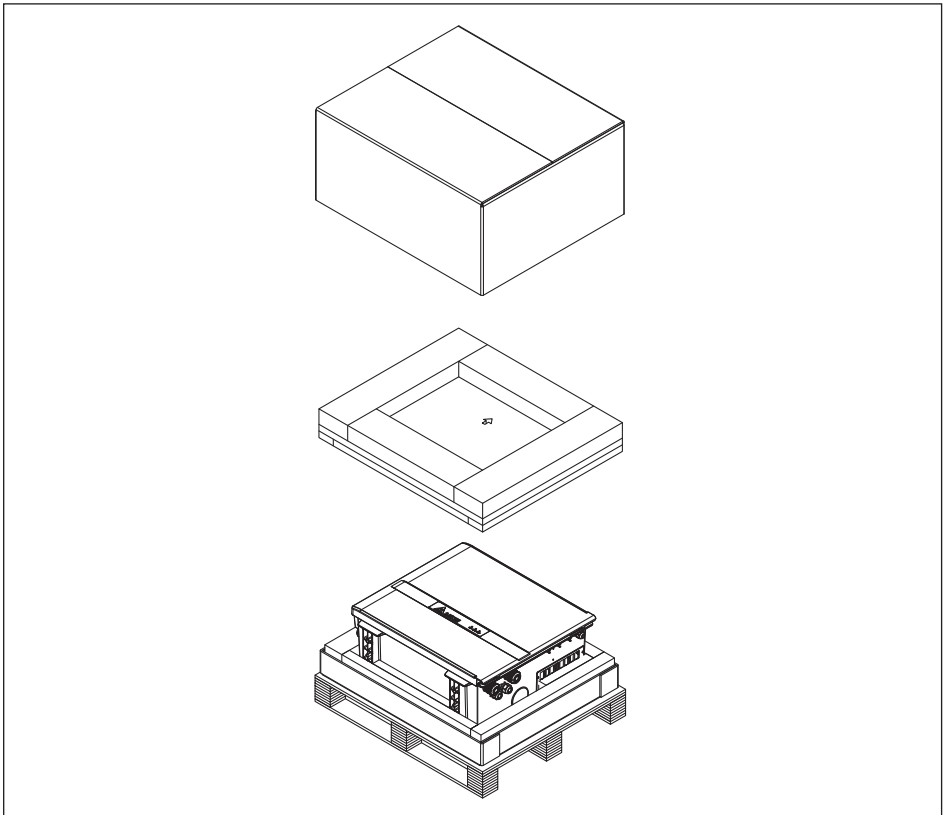

Figure 3-1: The step to unpacking the inverter

CAUTION !



- Need more than two people to stand up.
- It is recommended to install the grounded brackets first at this step for ground mount installation. For detailed installation methods, please see **section 3.2**.

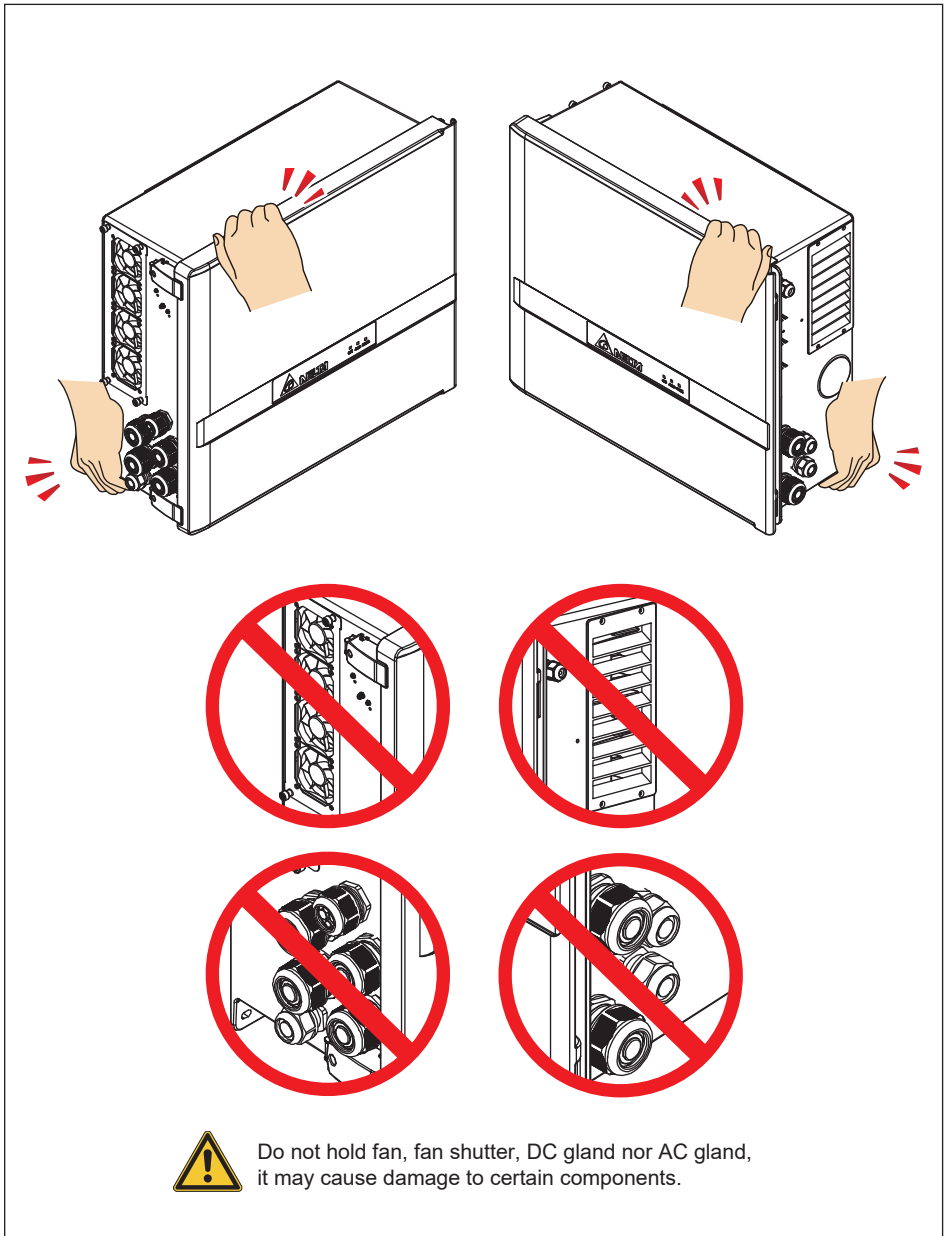

Figure 3-2: Hand hold position for lifting

3.2 Mechanical Installation

M100_210 only can be carried out vertically, the tilting must be in the range of the maximum inclination as **Figure 3-3**.

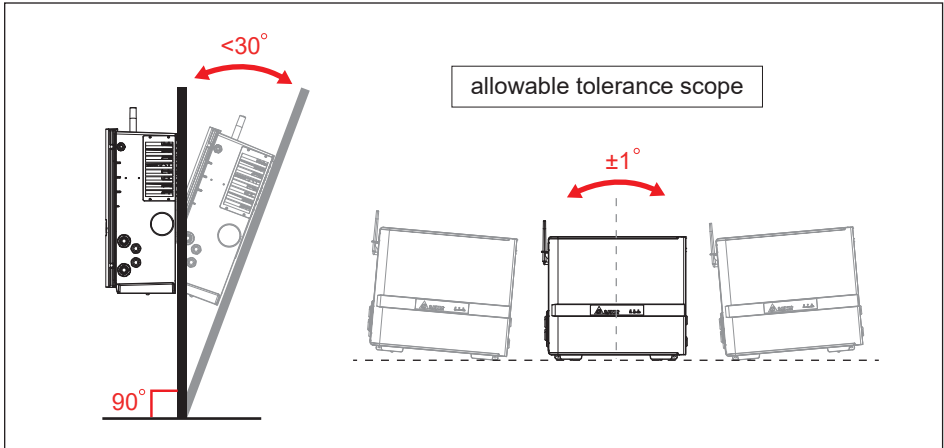

Figure 3-3: Permitted mounting positions

CAUTION !



To avoid malfunction of inverter caused by extreme weather (ex: snow, hail...etc) or non-proper installation/maintenance, an additional protection cover is strongly recommended to be installed by DELTA.

For more details, please contact local service team.

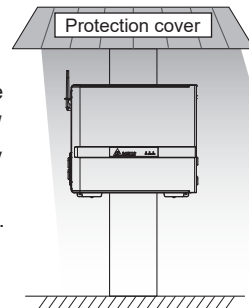

WARNING !



- Do not install the unit near or on flammable surfaces.
- Inverter must be mounted securely to a solid / smooth surface.

3.2.1 Wall Mount

Refer to **Figure 3-4** through **Figure 3-8**.

1. Ensure the surface to which the unit is to be mounted is sufficiently strong enough to carry the weight.
2. Orient the wall bracket (**Figure 3-5**) horizontally (perpendicular to the floor).
3. Secure the mounting bracket on the wall with 12 M6 screws. (**Figure 3-6**)
4. Hang the inverter on the wall mounting bracket.
5. Two external grounding points can help to fix the inverter by 2 M8 screws.

CAUTION !



- The mounting bracket shipped with the unit is specially designed and is the only certified mounting device for mounting the inverter.
- Secure the mounting bracket on the wall with at least 8 M6 screws.

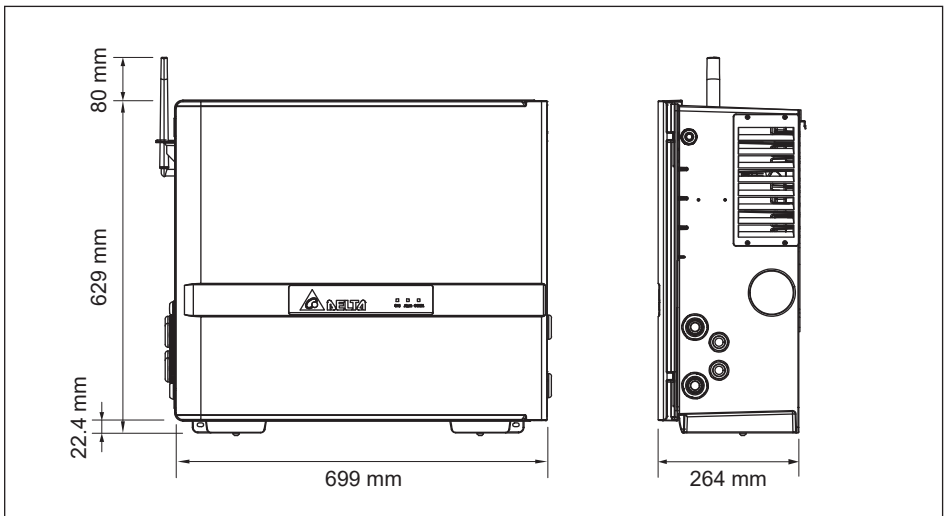

Figure 3-4: Inverter dimensions

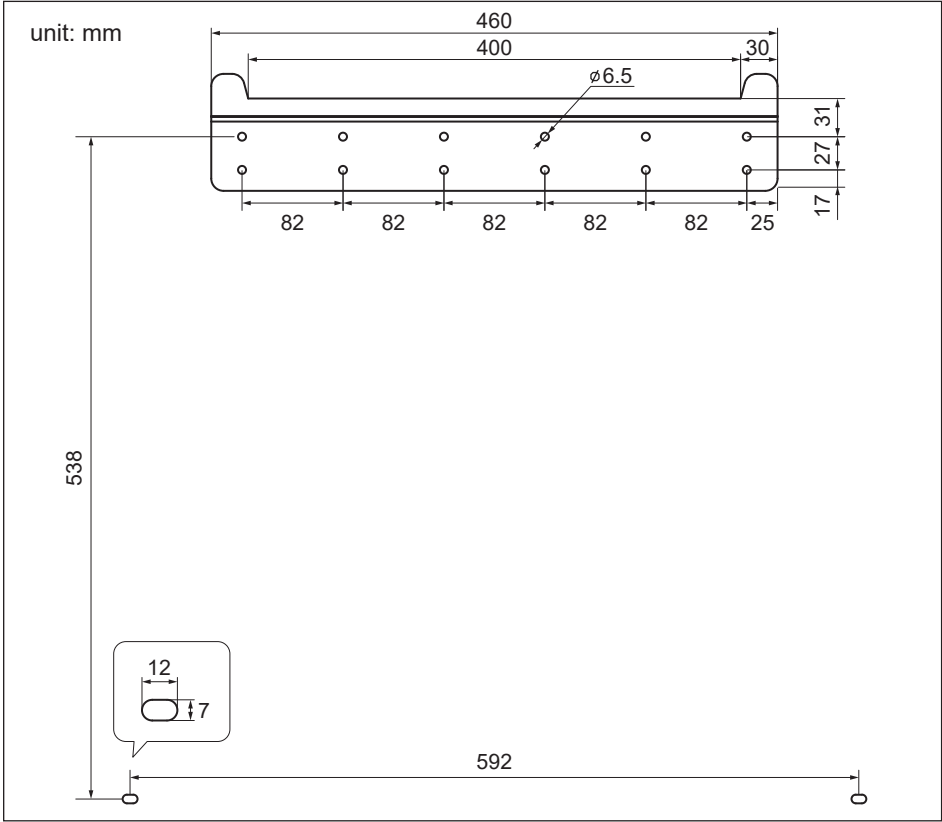
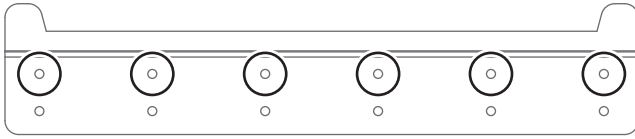

Figure 3-5: Mounting bracket dimensions

Positions for least amount of mounting bracket screws



or

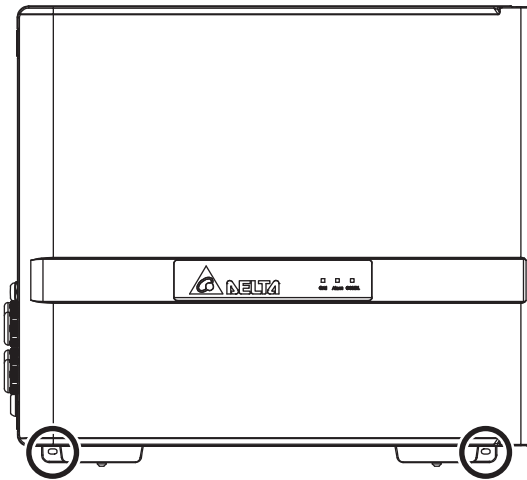
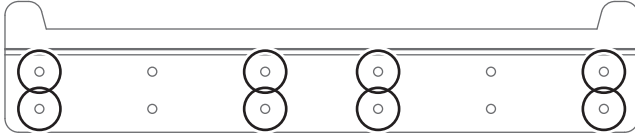

Figure 3-6 : Positions of mounting screws

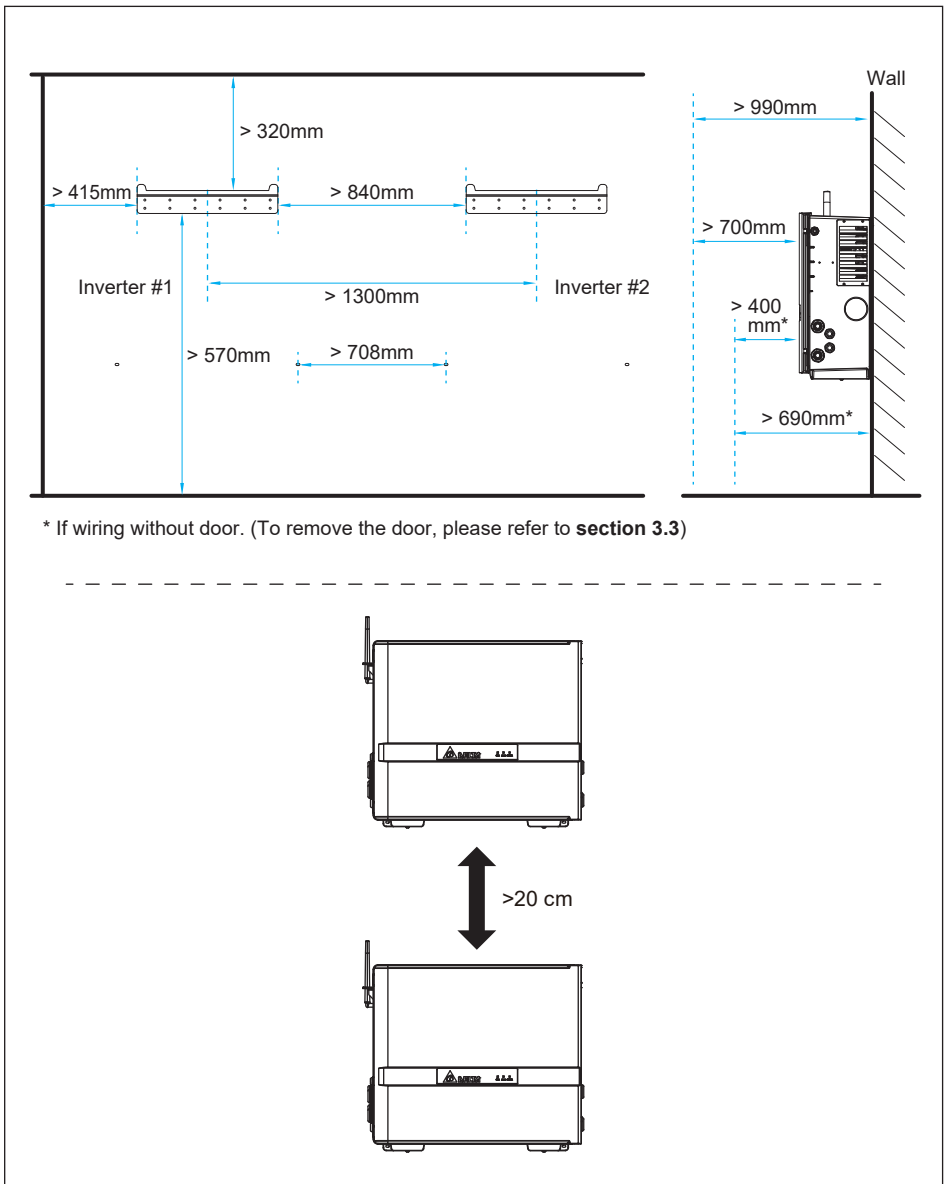

Figure 3-7: Required mounting clearances

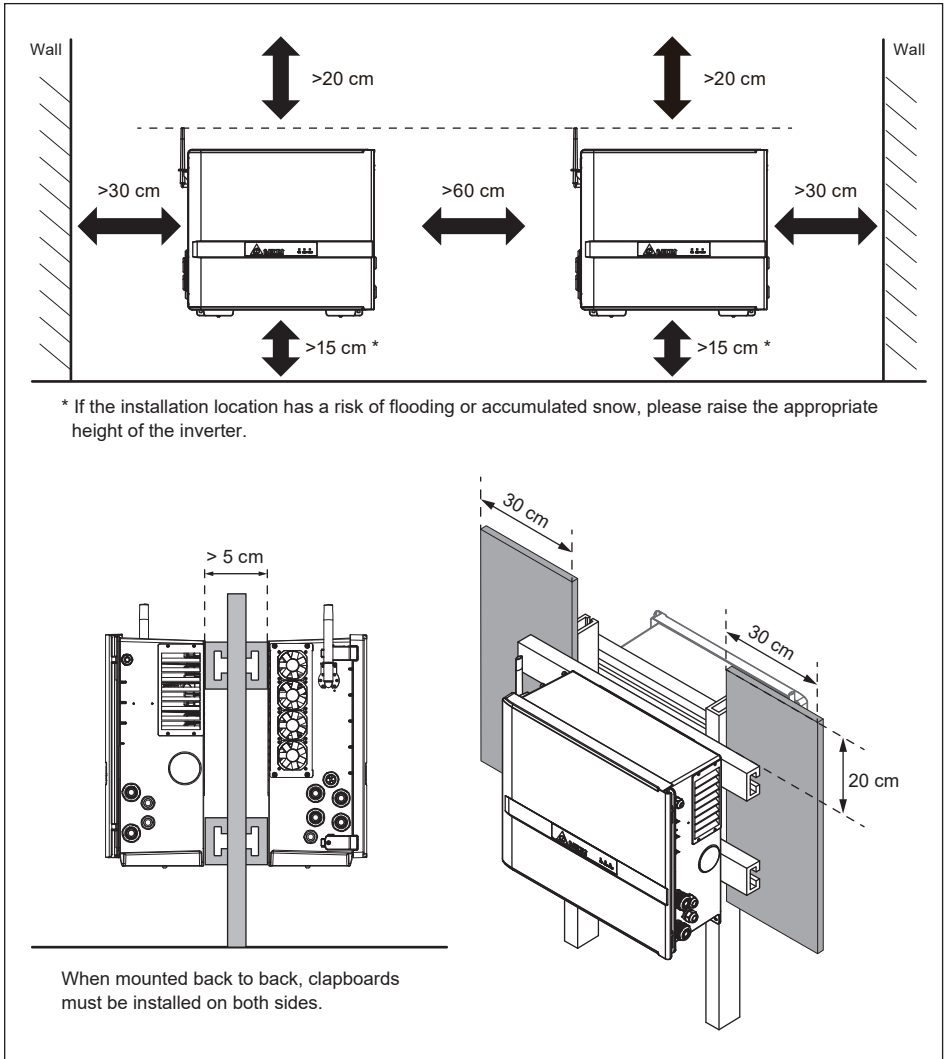

Figure 3-8: Separation distance of plural inverters

CAUTION !



- Failure to comply with above mounting instructions including permitted orientations and designated clearances may result in derated power output and may void the warranty. To avoid these issues follow the instructions above!

3.2.2 Ground Mount (optional)

ATTENTION



- Ensure the grounded base is strong enough to hold the weight of the inverter.

Grounded Bracket kit is an optional part, please contact the customer service center for the detail.

1. Fix the grounded brackets to the bottom of the inverter as **Figure 3-9**.
2. Mount the inverter with grounded brackets to the ground-mounting base by 4 expansion bolts. (**Figure 3-10**)

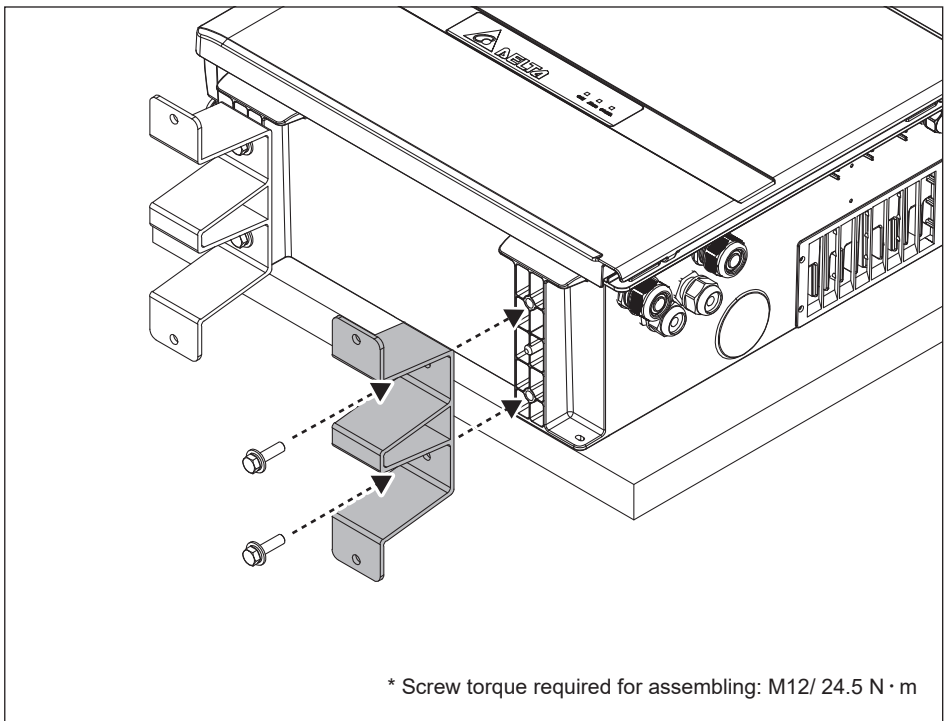

Figure 3-9 : Lock the grounded brackets to feet

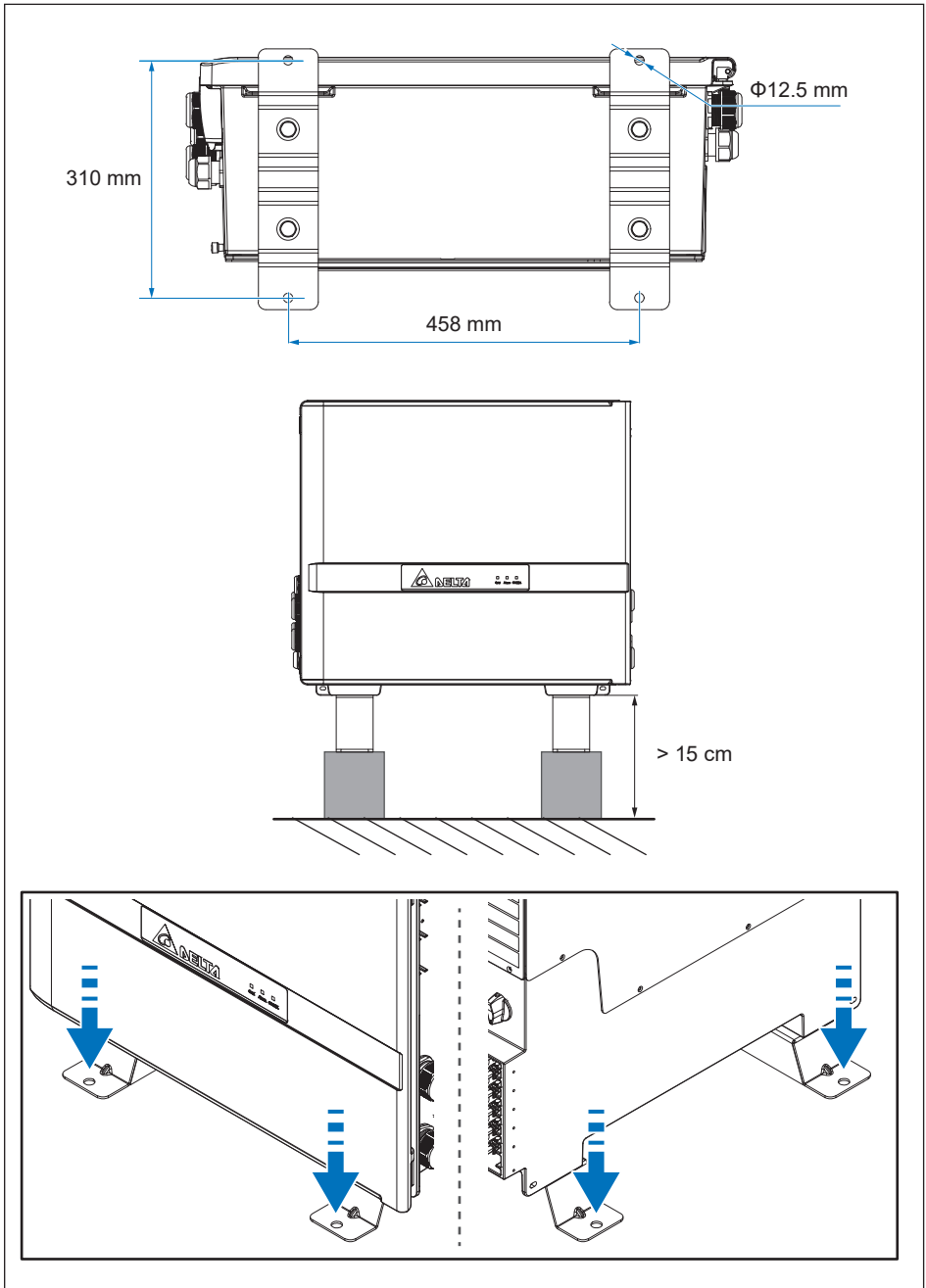

Figure 3-10: To secure inverter grounded brackets to ground-mounting base

3.3 Route the cables to M100_210

Proper cable routing can avoid water dripping to cable glands and make the sealing of the cable glands well. Please follow the requirements to lay cables for M100_210.

1. Keep 10-20 cm length of straight cables from the edge of cable glands.
2. Anchor or support the straight cables to strain relief.
3. Must be routed to create a “hump” to prevent flowing water on the cable gland.

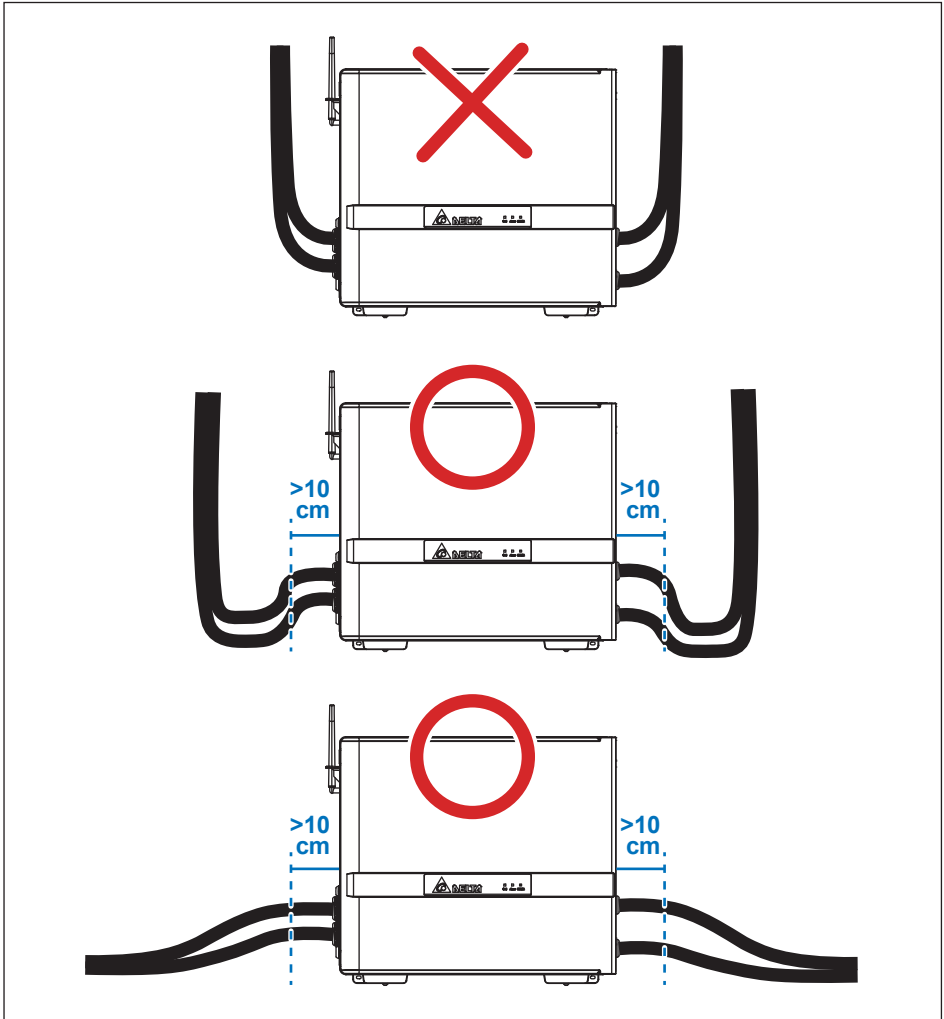

Figure 3-11: Cable routing

Please do not separate the three phase AC cable into individual metal conduit to avoid eddy current affect, please refer **Figure 3-12** for AC cable installation suggestion.

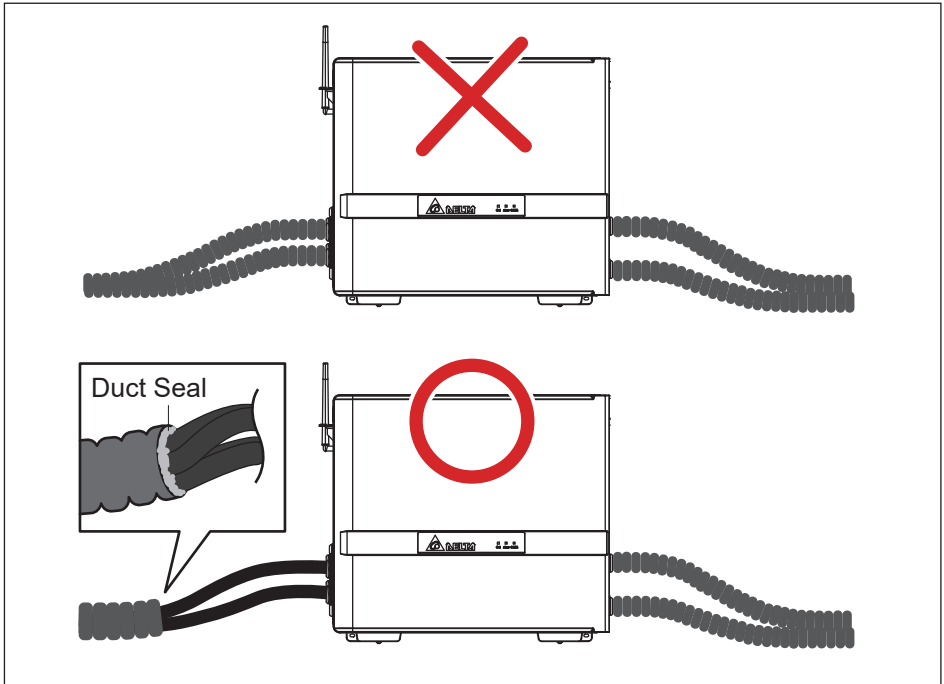
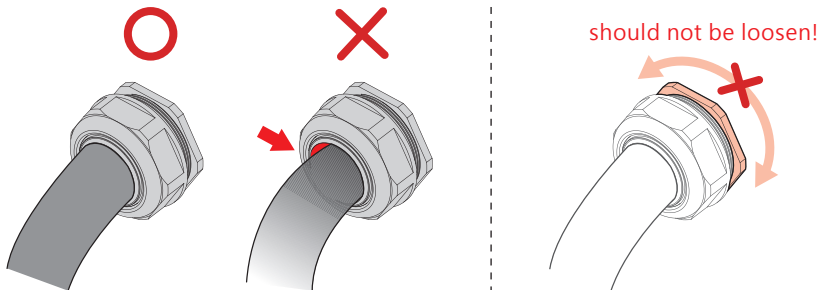

Figure 3-12: AC side metal conduit installation suggestion

CAUTION !



- Please make sure there is no gap between gland and cable.
- Please make sure the gland is tight after setup as shown below.



3.4 Electrical Installation for AC Wiring

DANGER : ELECTRICAL HAZARD!!



- To avoid shock hazard during cabling, insure any live grid connections are removed from the inverter.

WARNING !



- Code compliance is the installer's responsibility.
- Inverter warranty void if the DC input voltage exceeds 1100 Vdc.

CAUTION : INVERTER AND EQUIPMENT DAMAGE MAY OCCUR !



- Installation for AC terminal must meet the local electrical code.
- Failed to follow the instructions may damage AC cable.

CAUTION: WRONG AC WIRING !



- In order not to damage the components in the inverter, ensure the correct conductor is connected to the appropriate AC terminal on the inverter.

Please follow the instruction of **Section 5.1** to open or close M100_210 door.

3.4.1 AC Grid Types and Connections

ATTENTION



The default AC Grid connection is 3Ø-4W. It can also connect 3Ø-3W without Neutral (N). The inverter will operate from the following grid connections without need of an external transformer:

TN-C

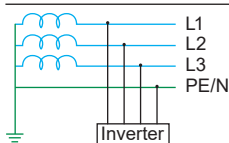

TN-C-S

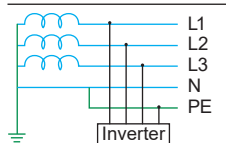

TN-S

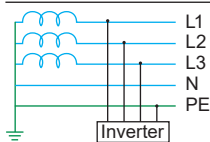

TT

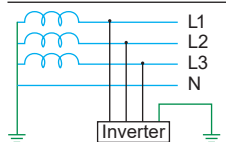

IT *

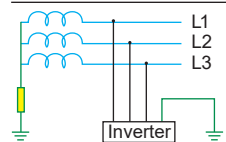

* Make sure the voltage from L1, L2, and L3 to PE(Protection Earth) in IT system is always in the range of $\pm 600V$.

3.4.2 Required Protective Devices

Overcurrent protection device on AC wiring is recommended. Install a three-phase AC circuit breaker that can protect the AC wiring of the inverter and safe for the system maintenance. The minimum requirement of the AC circuit breaker for M100_210 is in the below table.

Table 3-1: Recommended AC circuit breaker rating

Current rating	min. 200A
Voltage rating	min. 380V / 400V
Number of poles	3 / 4

3.4.3 Preparation for AC Wires Connection

Requirements of AC cable for M100_210 are:

- Only accept cooper or aluminum cables to be used
- Cross-section is from 70mm² to 185mm²
- Outer diameter is from 12.0mm to 28.9mm
- Stranded and Solid wire is available. Bootlace ferrules must be when using the flexible wire.

ATTENTION



- The worry of Ingress Protection on the cable gland, Multicore cable is not recommended to be used.

3.4.4 Preparation for PE cables Connection

The inverter must be grounded via the internal or external PE point which should follow below requirements.

- Cross section of the conductor must be at least ½ of AC cable cross section
- Must follow the below table to use the proper lug for the connection

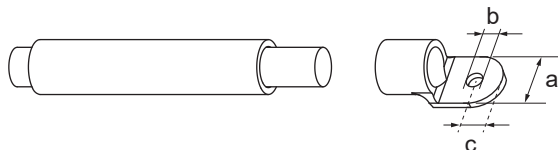

	Internal PE	External PE
Max. conductor cross section	120mm ²	120mm ²
Cable diameter range	9.5 - 18.8mm	-
Cable lug dimension	Size of bolt = M8 a < 24.0mm b = 10.5mm c < 12.5mm	Size of bolt = M8 a < 24.0mm b = 10.5mm c < 12.5mm

3.4.5 Install PE Cables

CAUTION !



- The ground connection in the first step is recommended because the earthed outer casing of the inverter can protect the persons against electrical shocks.

M100_210 has one internal and two external PE terminal for grounding. The ground connection can be installed on the internal, external or both with the proper sizing of the cable refer to **3.4.4**.

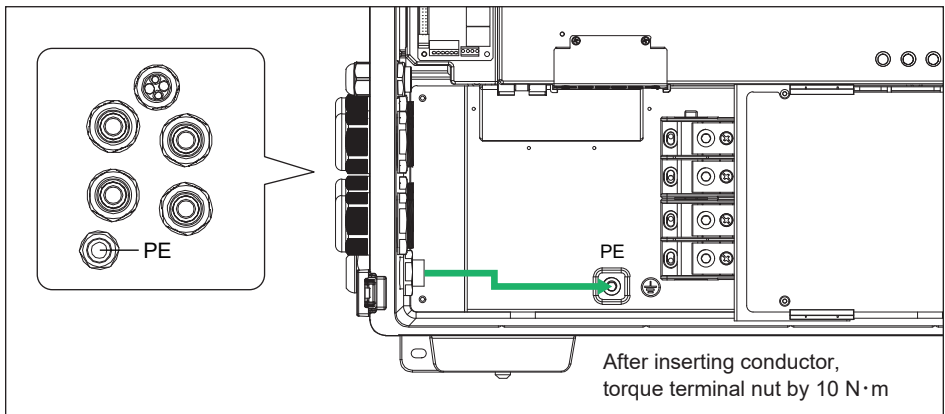
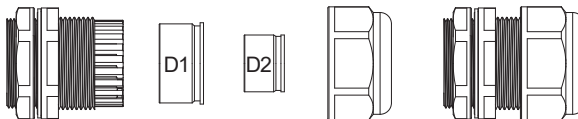

Figure 3-13: Location for internal PE terminal

Internal PE terminal

- (1) Pass PE cable through M25 cable gland to the Internal grounding terminal with the proper inner rubber.



	Cable diameter range	Torque	Dimension of P
D1	14.1-18.8 mm	3.5-5.2 N·m	1.5-5.0 mm
D2	9.5-14.1 mm	3.5 N·m	1.5-5.0 mm

- (2) Use M8 spanner to tighten the nut with 10 N·m torque.
- (3) Fasten the protective earth cable gland for sealing.

External PE terminal

To ground the inverter, please crimp the grounding wire to the ring terminal lug and fix it on the grounding point shown as **figure 3-14**.

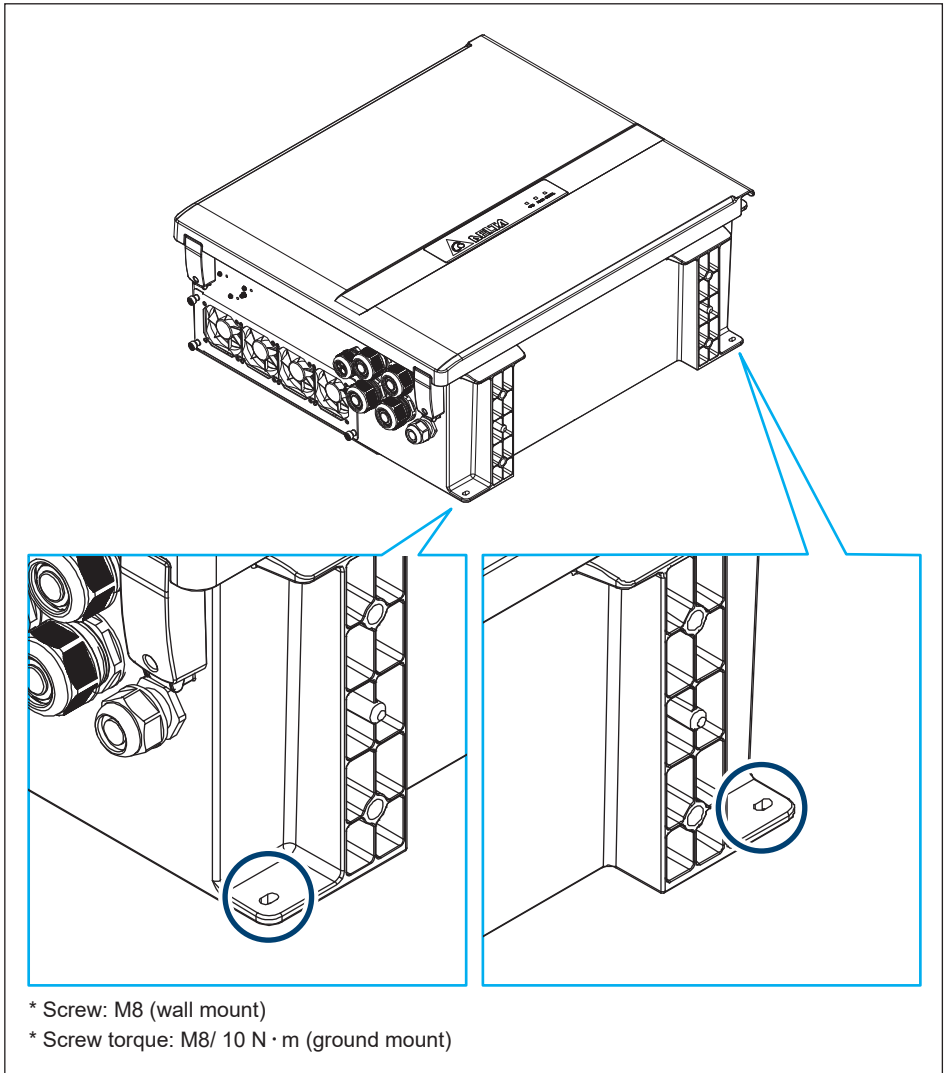

Figure 3-14: Mount the equipment grounding

3.4.6 AC Wiring

DANGER : ELECTRICAL HAZARD!!



- Always no energy on the AC power cables during the cable installation to prevent electrical hazard.

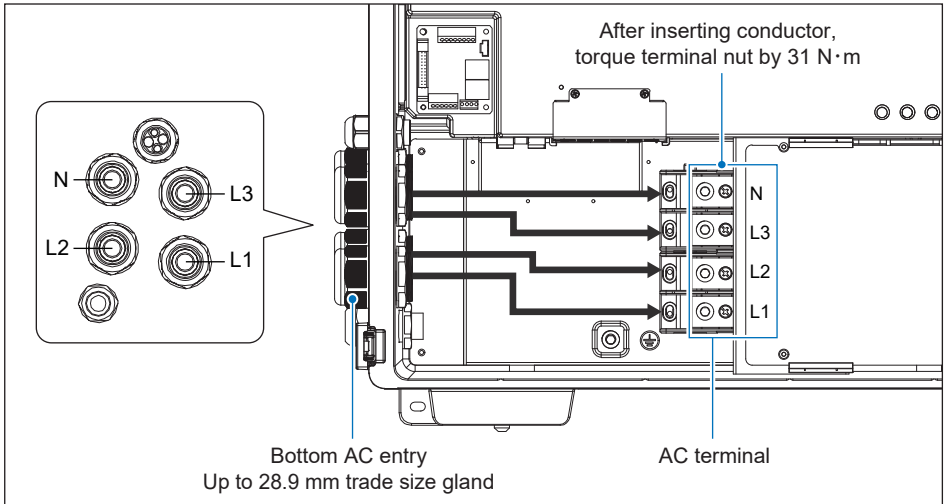

Figure 3-15: Location for AC terminal

- (1) Ensure the AC disconnect device is in “OFF”
- (2) Strip off the insulation of each cable by 30mm.
- (3) For the aluminum conductor, remove the oxide film of the conductor surface and apply the protective grease.
- (4) Pass the cable of L1, L2, L3 or neutral (if required) through each M40 cable gland with the proper inner rubber.
- (5) Follow the label to Connect L1, L2, L3 and neutral (if required).
- (6) Tighten all screws of the terminal with 31 N-m torque.
- (7) Fasten all AC cable glands for sealing.

CAUTION !



- After AC cabling, please check if there are gap inside the cable gland, if yes, suggest to use silicon or duct seal to fill the gap.
- When using plastic or HDPE conduit cabling, please use silicon or fire mod to fill the gap and conduit.

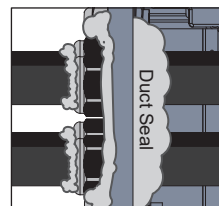

3.5 Electrical Installation for DC Wiring

DANGER : ELECTRICAL HAZARD!!



- High energy on DC cables from PV combiner boxes could cause dangerous electrical shock. Ensure DC cables are always de-energized until finish the DC wiring installation.

WARNING !



- The risk of electric shock and fire exists because of high DC and AC voltages.
- Only PV modules that are listed with system voltage under 1100V are permitted for use.

ATTENTION



- M100_210 will check the insulation resistance of DC wiring before the first time operation every day. However, DC ground fault still could damage the inverter during the operation and not covered by warranty.
- Ensure no ground fault occurs on DC cables.

Please follow the instruction of **Section 5.1** to open or close M100_210 door.

3.5.1 Preparation for DC Wires Connection

- Only copper or aluminum cables are acceptable to be used
- Stranded and Solid wire is available
- Must be equipped with the terminal lug
- Must be using bi-metallic cable lugs for the aluminum conductors to prevent electrochemical corrosion

M100_210 can support one or two PV combiner boxes input. The requirements of the DC cable for the two cases are different.

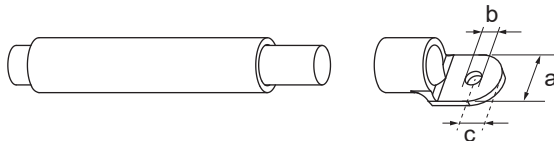

Case of DC input	1 PV combiner box	2 PV combiner boxes
Max. conductor cross section	185mm ²	120mm ²
Cable diameter range	12.0 – 28.9mm	9.5 - 18.8mm
Cable lug dimension	Size of bolt = M10 a < 40.0mm b = 10.5mm c < 16.0mm	Size of bolt = M10 a < 40.0mm b = 10.5mm c < 16.0mm

3.5.2 Install DC cables

WARNING !



- Before the DC wiring installation, make sure all DC isolator switches in the PV combiner boxes are OFF and locked for safety.
- Check through the meter for no voltage on both poles of DC cables before touching DC conductors.

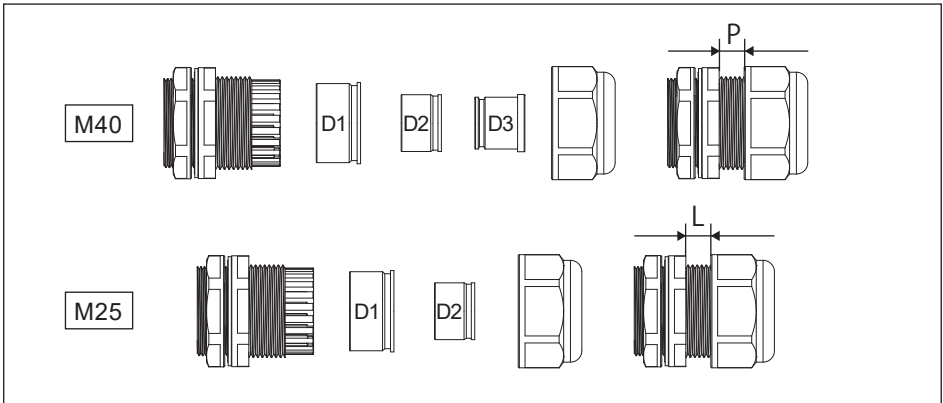

Figure 3-16: DC Gland with multiple inlet

Table 3-2: Cable size comparison table

M40	Cable diameter range	Torque	Dimension of P
D1	21.7-28.9 mm	5.5-10 N·m	1.0-8.0 mm
D2	16.2-21.7 mm	6.0 N·m	1.0-6.5 mm
D3	12.0-16.2 mm	4.0-6.5 N·m	1.0-7.5 mm

M25	Cable diameter range	Torque	Dimension of P
D1	14.1-18.8 mm	3.5-5.2 N·m	1.5-5.0 mm
D2	9.5-14.1 mm	3.5 N·m	1.5-5.0 mm

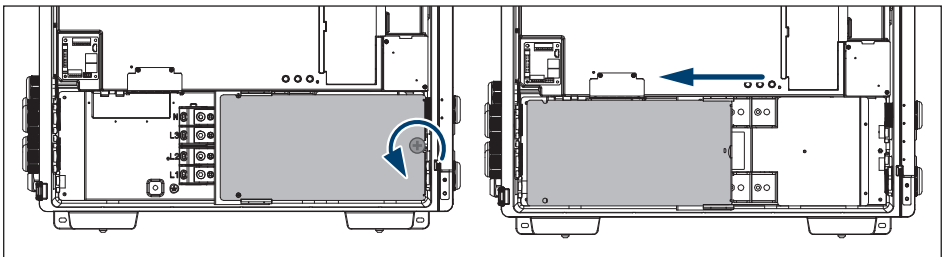

Figure 3-17: Slide the protective cover

WARNING !



- Reverse pole connection is prohibited that will damage the inverter.
- Only accept under 1100V maximum PV strings to the inverter

One PV combiner box input

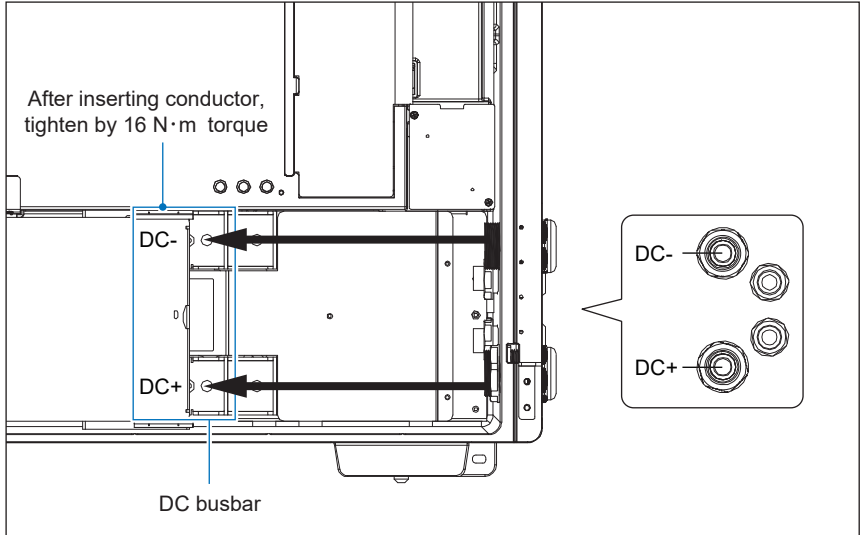

Figure 3-18: wiring of DC busbar (for 1 PV combiner box)

- (1) Pass PV+ or PV- cable through each M40 gland with the proper inner rubber
- (2) Follow the polarity as shown in **Figure 3-18** to insert PV+ or PV- cable to each terminal
- (3) Use M10 spanner to tighten nuts with 16 N-m torque
- (4) Fasten all M40 glands for sealing

CAUTION !



- After DC cabling, please check if there are gap inside the cable gland, if yes, suggest to use silicon or duct seal to fill the gap.
- When using plastic or HDPE conduit cabling, please use silicon or fire mod to fill the gap and conduit.

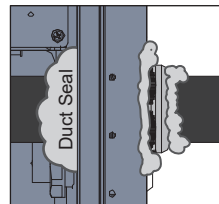

WARNING !

- Reverse pole connection is prohibited that will damage the inverter.
- Only accept under 1100V maximum PV strings to the inverter

Two PV combiner box input

Figure 3-19: wiring of DC busbar (for 2 PV combiner box)

- (1) Pass two pairs of PV cables (Total 4 DC cables) through M40 and M25 glands separately, the inner rubber of each cable gland must fit with the diameter of the cable.
- (2) Follow the polarity as shown in **Figure 3-19** to insert PV+ or PV- cable to each terminal
- (3) Use M10 spanner to tighten nuts with 16 N-m torque
- (4) Fasten all M40 and M25 glands for sealing

CAUTION !

- After DC cabling, please check if there are gap inside the cable gland, if yes, suggest to use silicon or duct seal to fill the gap.
- When using plastic or HDPE conduit cabling, please use silicon or fire mod to fill the gap and conduit.

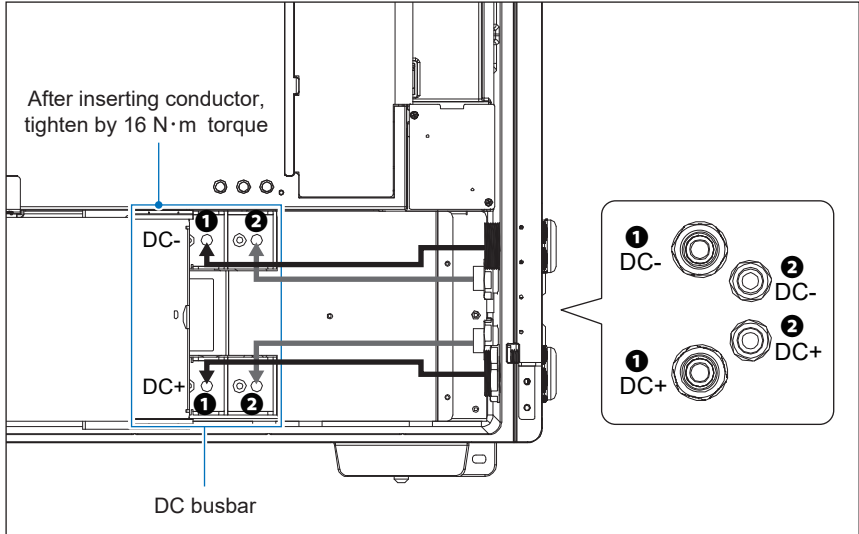
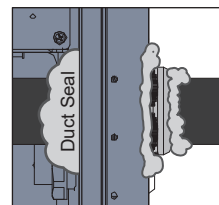

3.6 SUB_1G Antenna (optional)

Please follow **Figure 3-20** to **3-22** to install the SUB_1G antenna.

ATTENTION



- If the antenna and bracket are not installing on the case, ensure the nut and screws are properly tightened for the great Ingress protection.

Antenna
Location

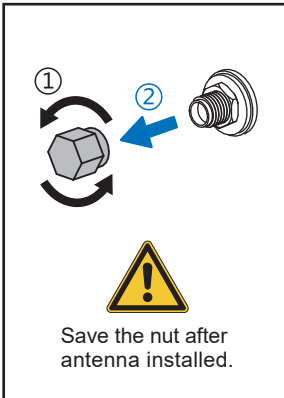
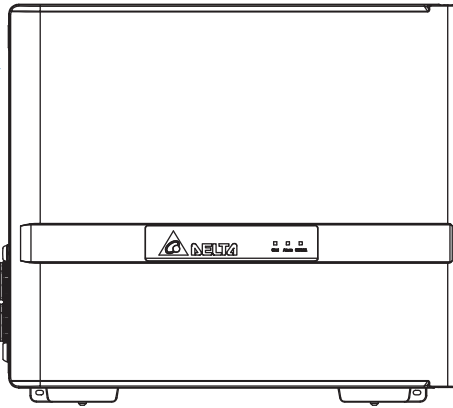

Remove the nut.

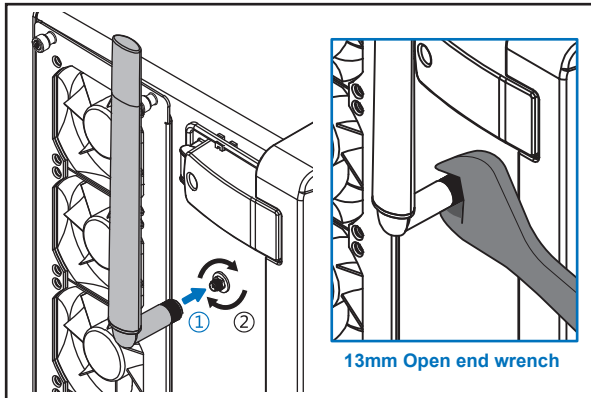

Use the wrench to lock antenna with 1.2 N · m torque.

Figure 3-20: Installation of antenna



There must be no obstacles within 20 cm around the antenna.

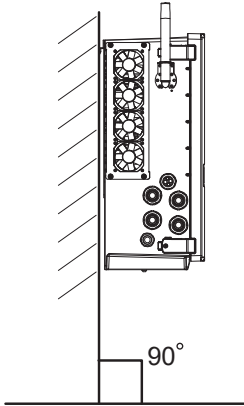
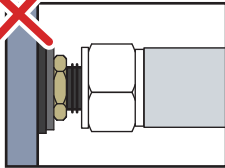
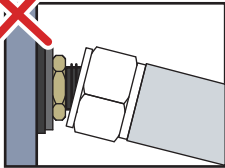
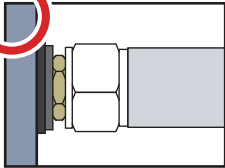
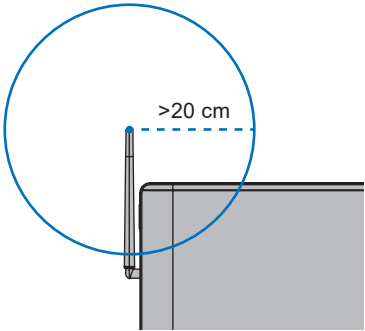

Keep antenna pointing upright.

Figure 3-21: Attentions of installing antenna

1. Remove the screws on the case and turn the antenna counterclockwise by about 45 degrees.
2. Put on the antenna bracket.
3. Turn the antenna to the proper position.
4. Tighten the 3 screws in the antenna package to the antenna bracket.

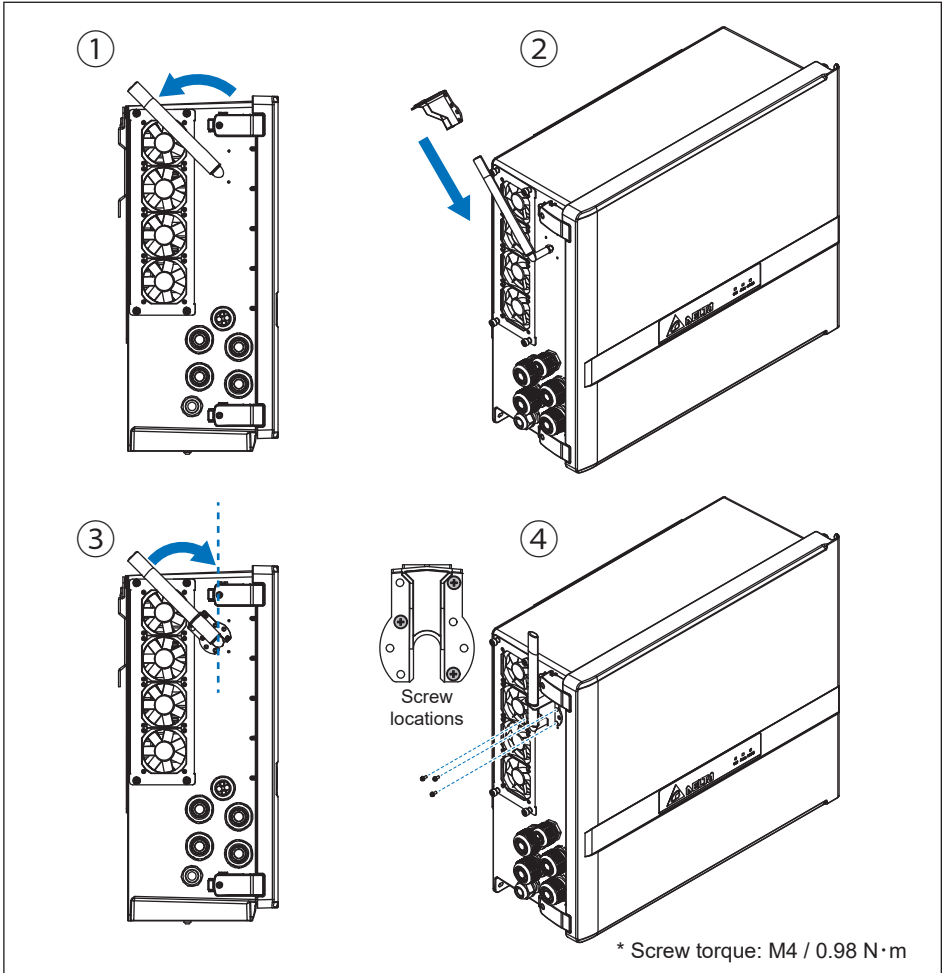

Figure 3-22: Install antenna bracket

ATTENTION



- Please refer Data Collector manual for connection of Data Collector.
https://mydeltasolar.deltaww.com/?p=product_manual



3.7 Communication

The communication module of M100_210 is shown in **Figure 3-23**. It provides VCC, RS-485, dry contact, EPO, and Digital Input terminals for use in various applications. Details for each are presented below.

There's a 12VDC source between VCC & GND for use with external device.

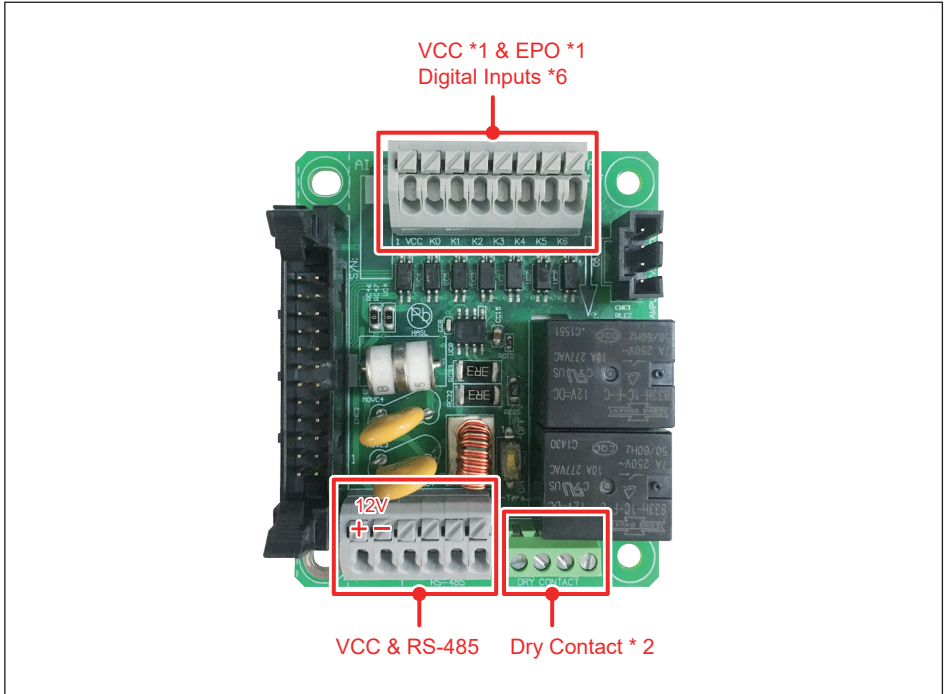

Figure 3-23: Communication Module Layout

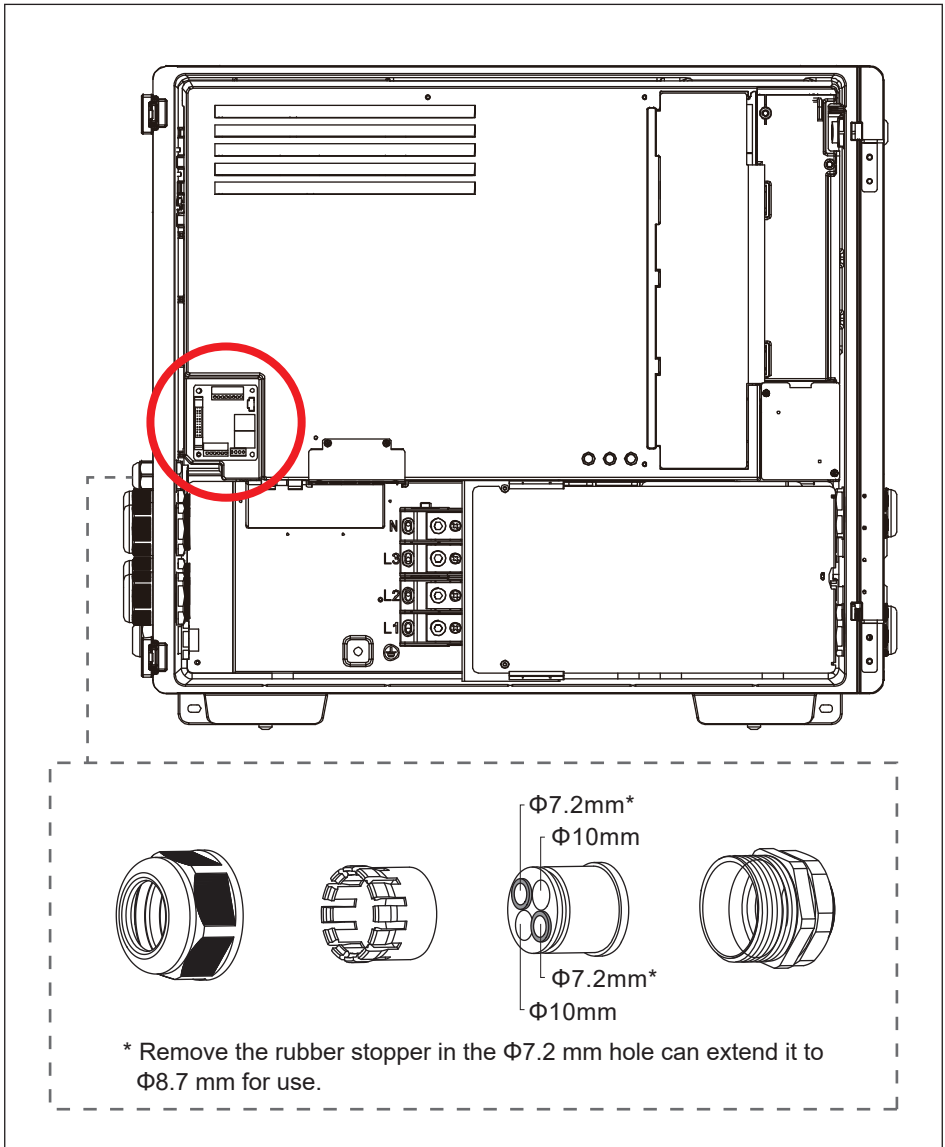

Figure 3-24: Location and access to Communication Module

3.7.1 RS-485 Connection

The pin definition for the RS-485 terminal block is shown in **Table 3-3**.

- Pins 1 and 2 provide a 12VDC / 0.5A bus for use with accessories.
- Pins 3 and 5 are both connected to the DATA+ input.
- Pins 4 and 6 are both connected to the DATA- input.

These connections allow easy daisy-chaining of multiple inverters.

A 120ohm bus termination resistor and associated control switch are located on the communication board (**Table 3-4**).

Different RS-485 connection scenarios require different set up for the 120ohm bus termination resistor.

- When several inverters are cascaded (i.e., "daisy-chained") only the last inverter in the chain must have its bus termination resistor switched ON (**Figure 3-25**).
- If the length of any RS-485 bus is greater than 610m, the use of Belden 3105A cable (or eq.) is recommended to insure communication quality.

ATTENTION



- In order to have good transfer quality, twisted-pair wire is recommended to be used as communication cable.

Table 3-3: RS-485 Terminal block wiring

Pin	Function
1	VCC (+12V)
2	GND (It is NOT the PE)
3	DATA+
4	DATA-
5	DATA+
6	DATA-

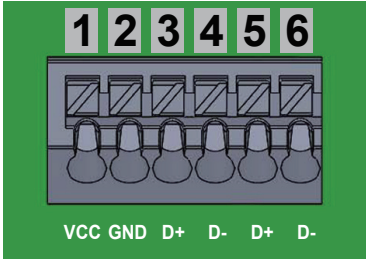

INFORMATION



When the RS-485 cable needs to be grounded, please follow the steps below.

1. strip a wire from the shielding layer and properly insulate it
2. crimp the insulated wire to the Y-type lug and fix it in position A

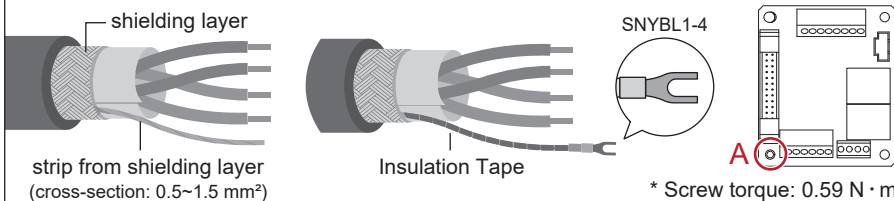

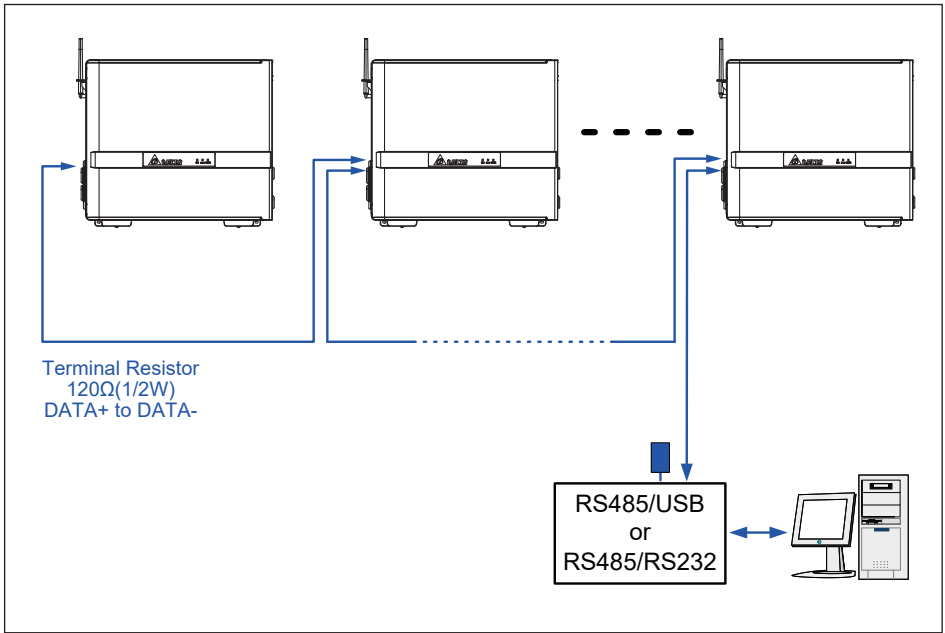

Figure 3-25: Multiinverter connection illustration

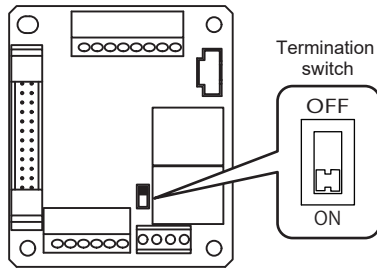

Table 3-4: Bus Termination switch settings

	Switch 1
ON	Terminal Resistor ON
OFF	Terminal Resistor OFF

3.7.2 EPO Function & Digital Input

The communication Module has an emergency power off function (EPO). Users can customize EPO function in APP or Delta Solar System (DSS).

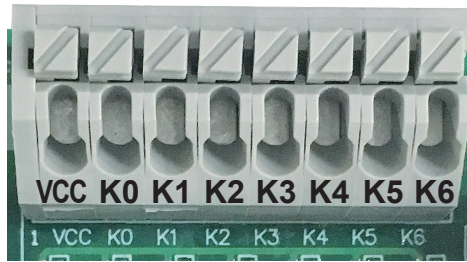

Figure 3-26: EPO function terminal block

Once enabled, the EPO function can be used to turn off the inverter via a NO relay contact connected across terminal [VCC & K0].

Additionally, a digital power reduction control is available that can be set to limit the inverter's available active output power. The control settings for this function are made by placing a hardware short (jumper or relay) between two terminals of the terminal block shown in **Table 3-5**, below.

Table 3-5: Definition of digital input & EPO function

Short terminals	Inverter's action
VCC & K0	Emergency power off (EPO)
VCC & K1	0% active power
VCC & K2	Maximum 30% rated power
VCC & K3	Maximum 60% rated power
VCC & K4	Maximum 100% rated power
VCC & K5	Reserved
VCC & K6	Reserved

3.7.3 Dry Contact Connection

M100_210 provides a dry control contact pair that may be used to control external devices based on the status of operation of the inverter.

The terminal block for this function is shown in **Figure 3-27**. The terminals marked in the figure identify the dry contact connection. The operation of the dry contact is normally open. The functionality of this contact can be customized by users via settings available in APP or DSS.

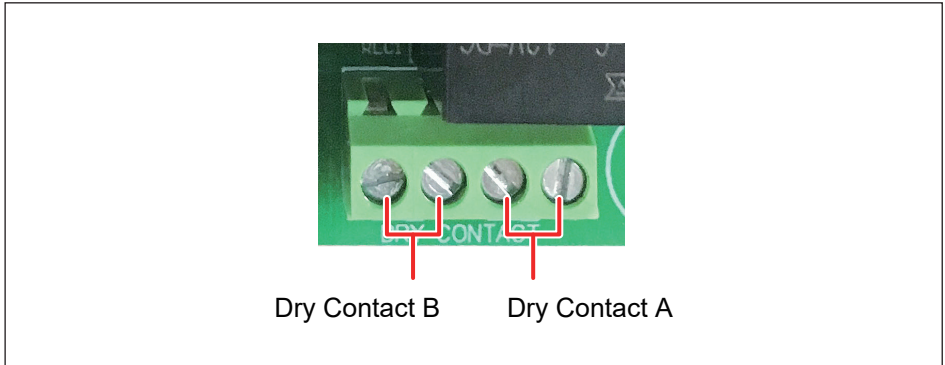

Figure 3-27: Dry Contact connection

4 Commissioning

CAUTION : HOT SURFACES, DO NOT TOUCH!



- Use care to avoid hot surfaces when operating the product!
- Do not perform any task until the unit cools down or appropriate personal protection gear is worn.

4.1 Display Operation Introduction

M100_210 with 3 LEDs allow visual display of the inverter's data and status as shown in **Figure 4-1**.

Please refer to **Table 4-1** for information as to the information provided by the LED indicators.

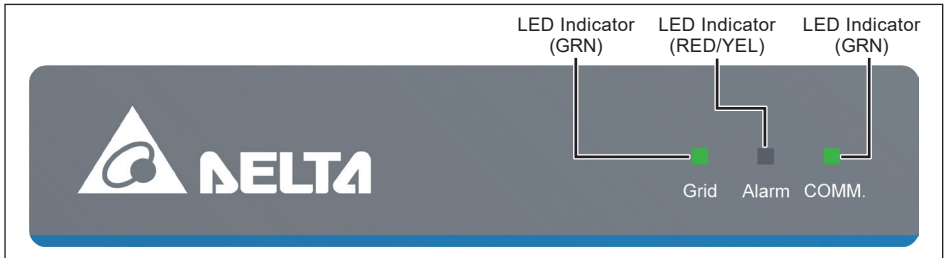

Figure 4-1: Front Panel Display

Table 4-1: Inverter status

Condition	Grid (Green)	Alarm (Red/Yellow)
Countdown	FLASH	OFF / OFF
On Grid	ON	OFF / OFF
Inverter Fault / Remote off	OFF	ON / OFF
Inverter Warning	ON (or OFF)	FLASH / OFF
Field Fault	OFF	OFF / ON
Field Warning	ON	OFF / FLASH
NO DC	OFF	OFF / FLASH SLOW
FW Upgrade	FLASH	FLASH / OFF
Standby	FLASH	OFF / FLASH
Check PV Power	FLASH FAST	OFF / FLASH FAST
System Lock	OFF	FLASH / FLASH

*FLASH: ON 1s / OFF 1s

FLASH FAST: ON 0.25s / OFF 0.25s

FLASH SLOW: ON 5s / OFF 10s

Table 4-2: Wireless communication status

Connection Status	COMM. (Green)
Wi-Fi and Sub_1G	FLASH (ON 1s / OFF 1s)
Wi-Fi	FLASH (ON 1s / OFF 2s)
Sub_1G	FLASH (ON 3s / OFF 2s)
Offline	OFF

4.2 Auto ID Commission

The Auto ID function can set all inverter IDs at once by DSS (Delta Solar System) or DeltaSolar APP.

- DSS

Connect the inverter through RS-485 or Wi-Fi with computer.

- APP

Connect the inverter through Wi-Fi with mobile device.

(please refer to **chapter 4.3** for operation manual.)

4.2.1 Commission Setting (DSS)

- ① Select the corresponding model
- ② Click “RS485”
- ③ Select communication port (automatic detection by the system).
- ④ Click 

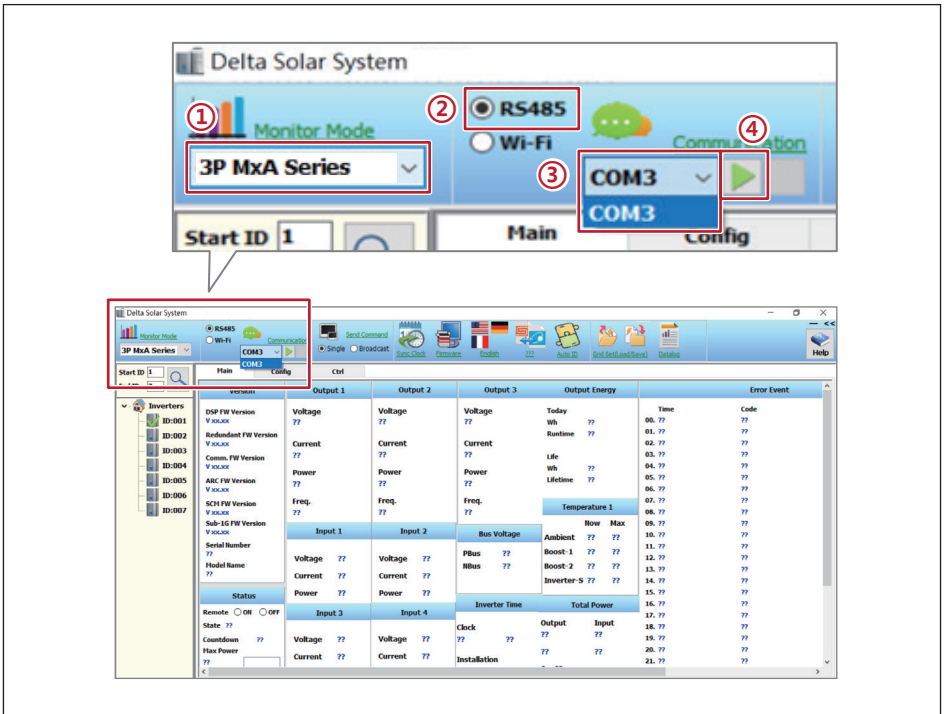



Figure 4-2: DSS Commission setting

4.2.2 Scan inverter

- ① Click “Auto ID ”.
- ② Enter numbers of inverters.
- ③ Click “Scan Inverters”.

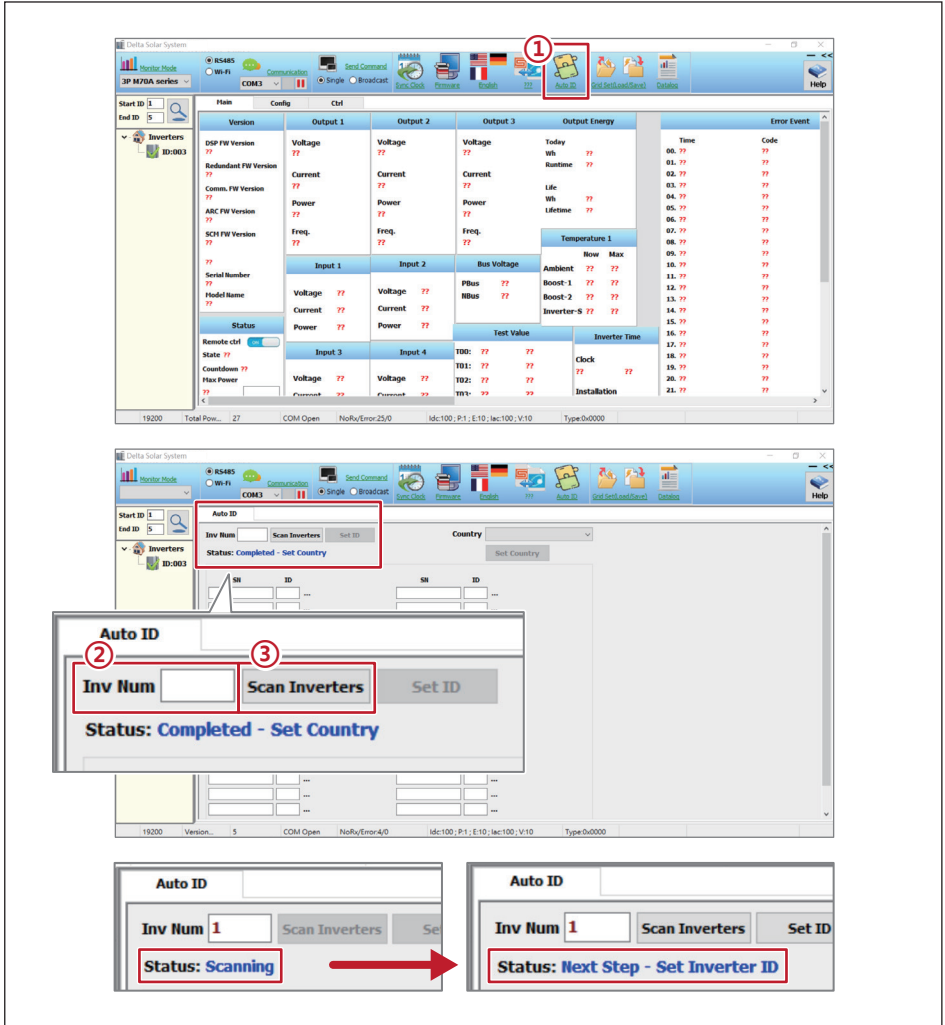

Figure 4-3: Steps of scanning inverters

4.2.3 Set ID

- ① The serial number of the successfully scanned device will be displayed, the default ID can be changed.
- ② After ID setting is completed, click “Set ID”.

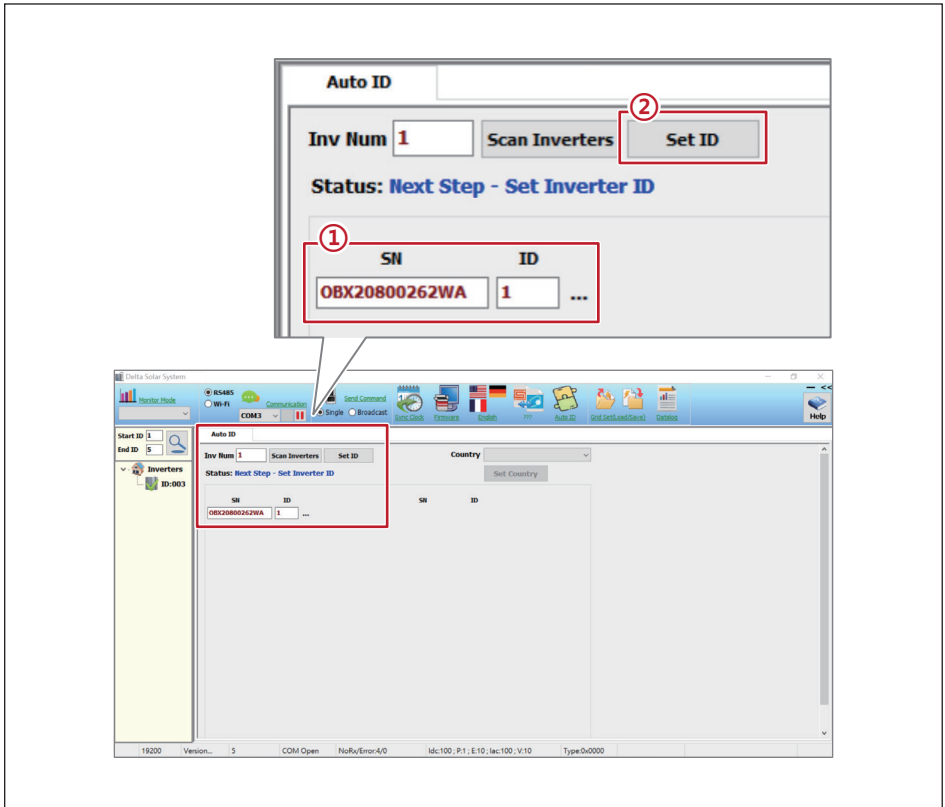

Figure 4-4: Steps of ID setting

4.2.4 Set Country

- ① Click to select the country of inverter.
- ② Click “Set Country”.

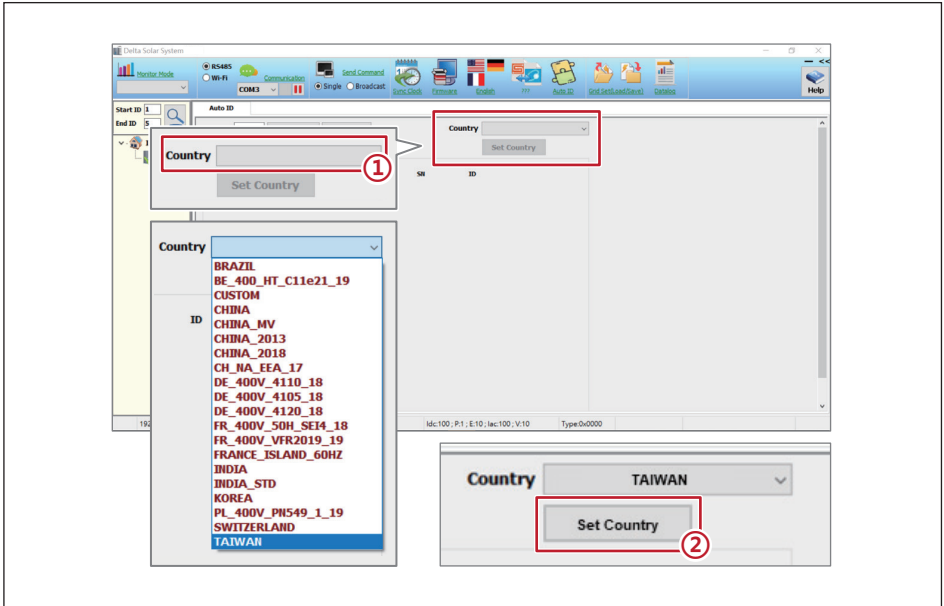

Figure 4-5: Steps of country setting

4.2.5 Synchronize time

Click “Sync Clock ” to Synchronize time.

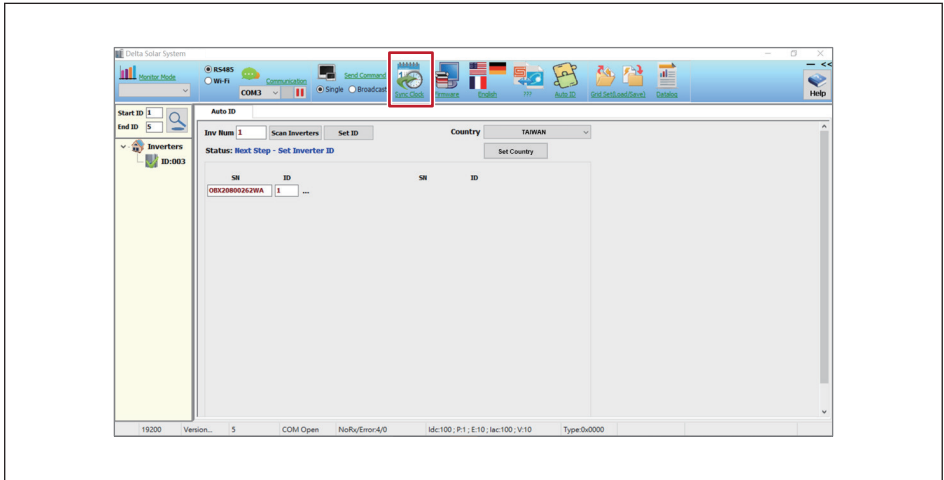

Figure 4-6: Steps of time synchronization

4.3 Delta Function Setting

Delta offers two setting tools:

DSS (Delta Solar System Software) and APP (MyDeltaSolar)

Function	
Active power control	Q(U) control (volt-var control)
P-F control (watt-frequecy control)	Q by night(Q setting 24/7)
P(U) control (volt-watt control)	Anti-PID
Fixed cosφ	Dry contact
Fixed Q(%)	ARC fault detection
Auto ID	Wi-fi

Please refer to the following link for operation manual.

DSS Operation Manual:



https://mydeltasolar.deltaww.com/manual/eng/SUB_1G/DSS.pdf

DeltaSolar (APP) Operation and Installation Manual:



<https://mydeltasolar.deltaww.com/index.php?p=manual>

5 Maintenance

Regularly maintenance can ensure that the inverter can keep great performance. DELTA recommends to have a check to the unit every year at least. The frequency of maintenance should be adjustable depends on the environment of the site, different seasons and weather impacts.

DANGER : ELECTRICAL HAZARD!!



- Ensure DC and AC cables are always de-energized during the maintenance to avoid the shock hazard risk!

5.1 Open and Close the Door

5.1.1 Disconnect M100_210 from Voltage Sources

1. Disconnect the AC Circuit breaker and secure to against reconnection.
2. Disconnect the DC switch which is in the PV combiner box or on DC Bus, then secure to against reconnection.
3. Wait 60 seconds and make sure LED indicators of the inverter have gone out.
4. To ensure there is no current in the cables, please use a current clamp to measure DC/AC cables.

5.1.2 Open Door

ATTENTION



- Before opening the front door, please wipe the inverter case if it is wet to avoid water seepage.

1. Remove screws of the antenna bracket.
2. Use the 4mm hexagon wrench to loose the screw of the protection cover, and then release the latch locks.
3. Open the inverter door and use the hexagon wrench to fix the door.
4. The inverter door can be removed for wider working space during installation or maintenance.

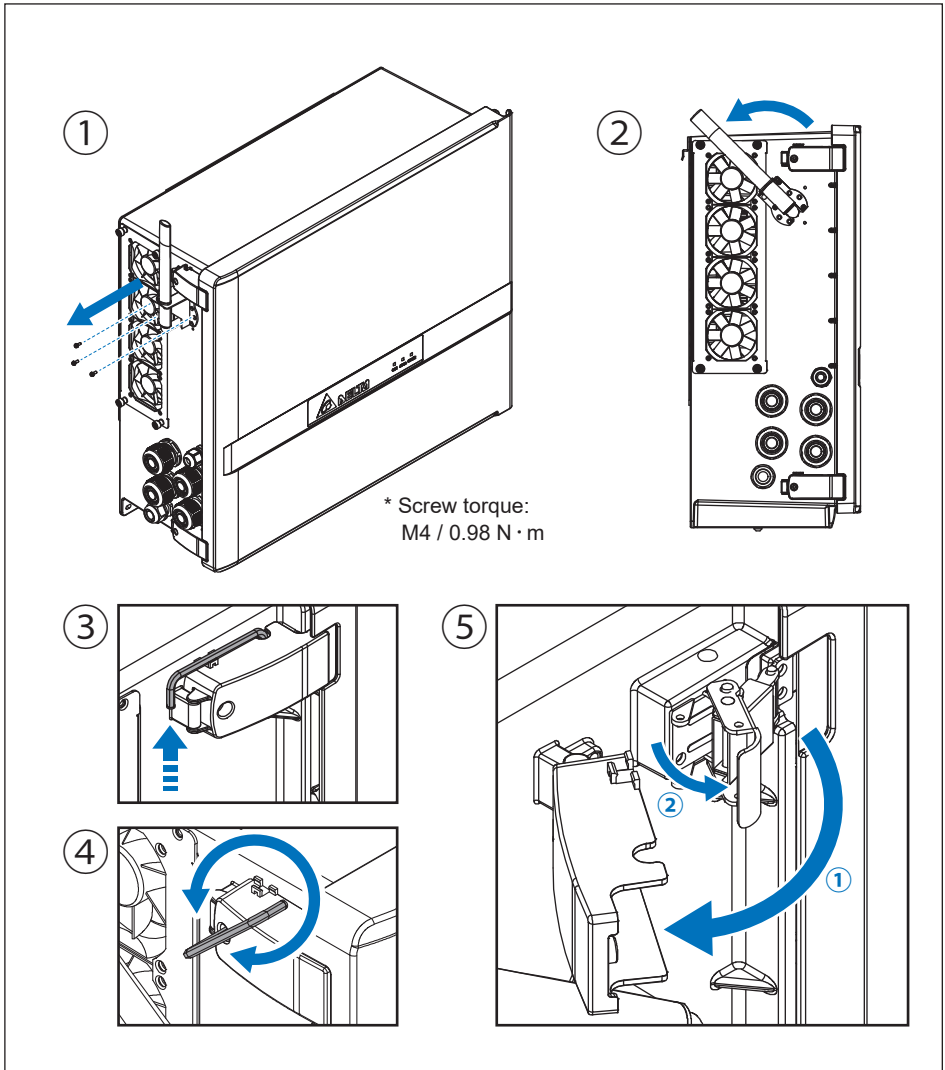
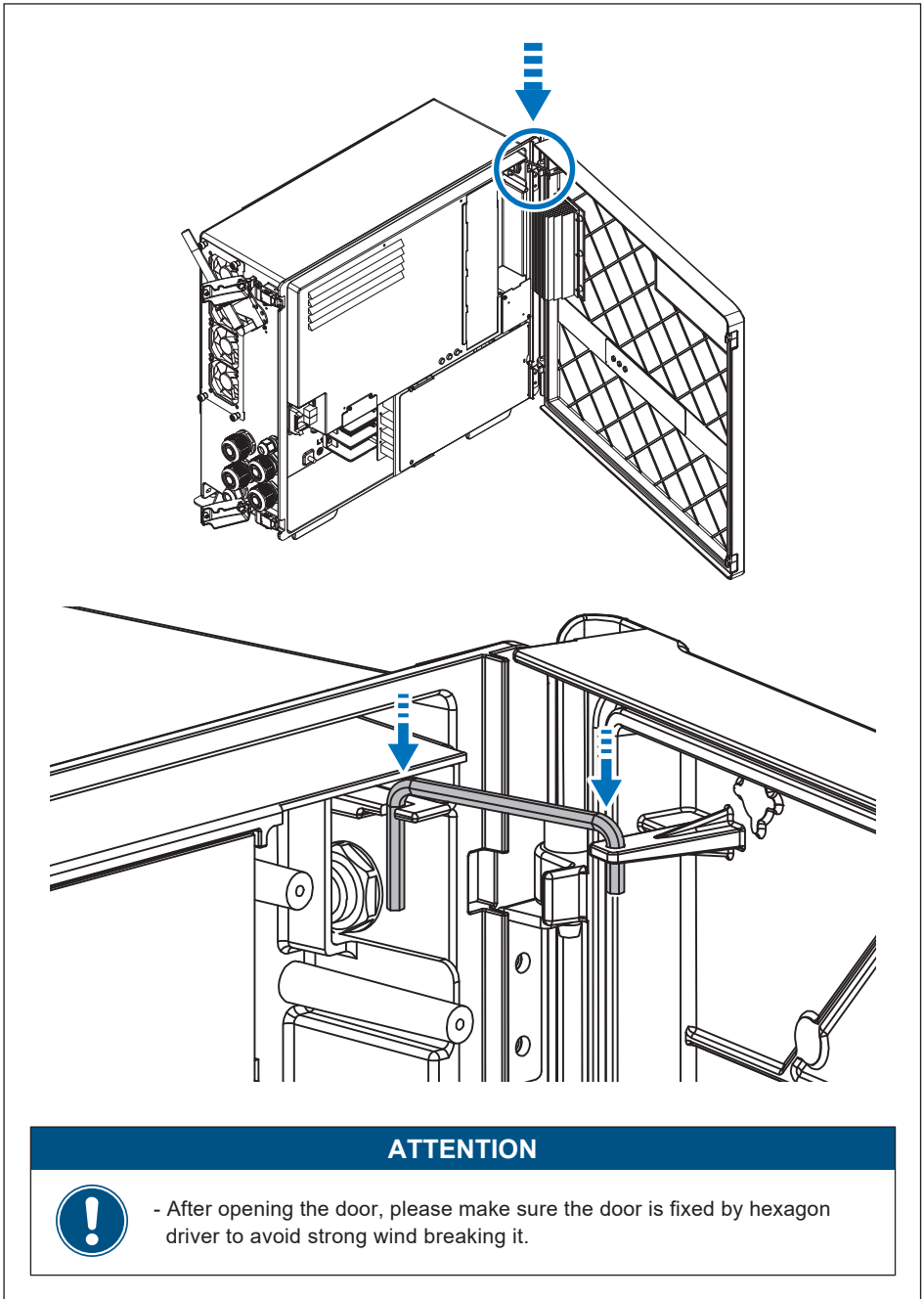

Figure 5-1: Opening and closing the door



ATTENTION



- After opening the door, please make sure the door is fixed by hexagon driver to avoid strong wind breaking it.

Figure 5-2: To secure door by hexagon driver

If the installation space is too narrow for wiring or maintenance, the front door can be removed as shown below.

After the operation is done, please install the door onto the inverter and follow the procedures in **Section 5.1.3** to close the door.

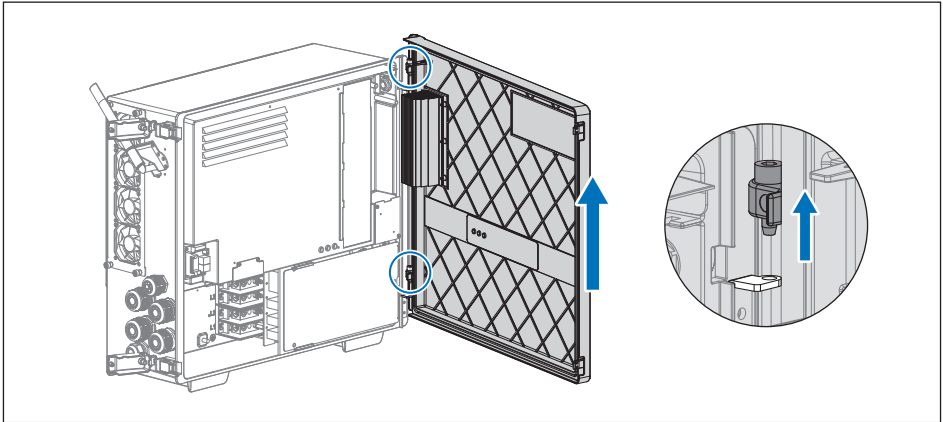

Figure 5-3: Remove the door

5.1.3 Close Door

ATTENTION



- Excessive moisture or dust in the inverter could cause unexpected damage due to the corrosion on the live part. Ensure the inner of the inverter clean without unreasonable pollution is important for a lifetime operation system.
- After cabling or maintenance for the inverter, please lock both toggle latch to make sure the inverter will remain IP66 protection.

1. Make sure that the terminals or viewable live parts are clean without sundries, dust even liquid.
2. All protection covers are installed well.
3. Remove the hexagon wrench and close the door.
4. Buckle the latch locks and fix its protection cover by the hexagon wrench with 2 N-m torque.
5. Fix the antenna with its bracket by 0.98 N-m torque.
6. The hexagon wrench can be fixed on the protection cover.

5.2 Replacement of Surge Protection Devices (SPD)

M100_210 has Surge Protection Device (SPD) for AC and DC wirings, which is behind the protective cover and can be replaced in damaged.

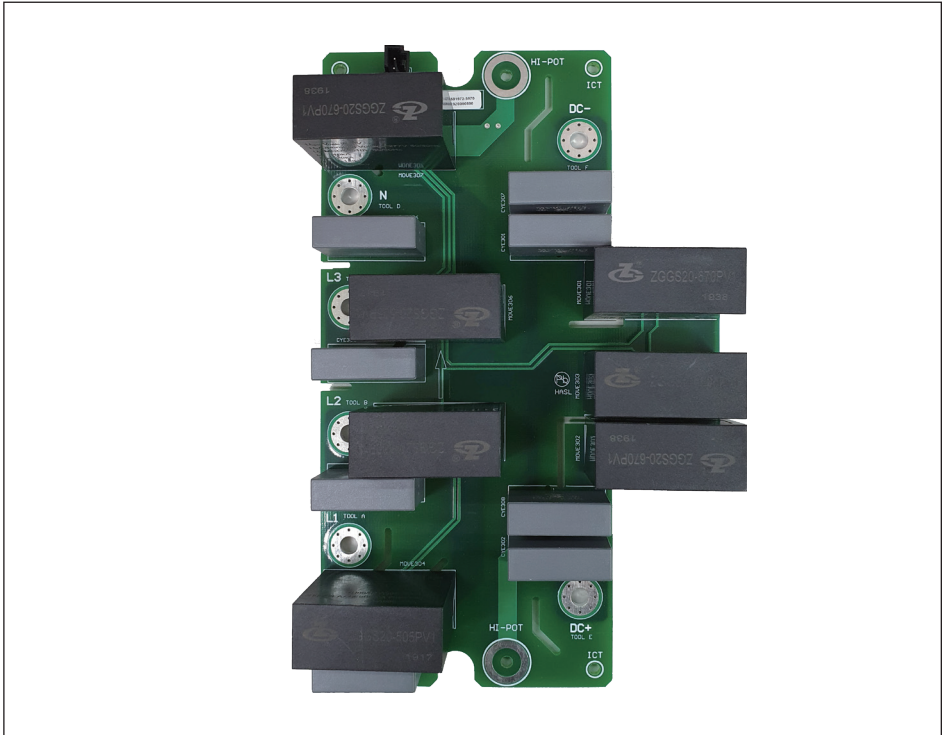

Figure 5-4: SPD module

5.2.1 Removing SPD

1. Follow Section 5.1.1 to disconnect M100_210 from Voltage Sources.
2. Follow Section 5.1.2 to open M100_210 door.
3. Remove the protective cover and then appear SPD. (**Figure 5-5**)
4. Press to release the lock of the header then remove the sensing cable.
5. Use PH2 screwdriver loose 8 screws to remove SPD. (**Figure 5-6**)

5.2.2 Installing SPD

1. Ensure the arrow on SPD is up to correctly mount on the AC / DC terminal.
2. Use PH2 screwdriver to tighten 8 screws on SPD with 0.8 N-m torque.
3. Connect the sensing cable to the slot and ensure to be locked.
4. Mount protective cover and use PH2 screwdriver to tighten 3 screws with 0.8 N-m torque.
5. Follow Section 5.1.3 to close M100_210 door to finish SPD installation.

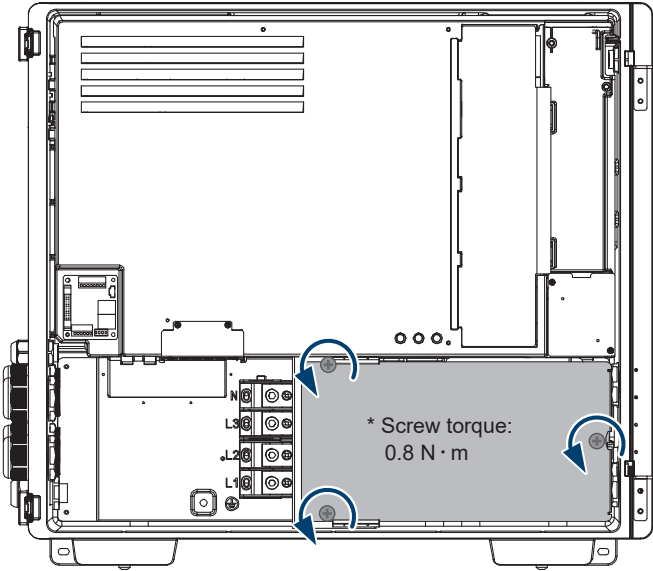

Please use manual pre-tighten before attaching.

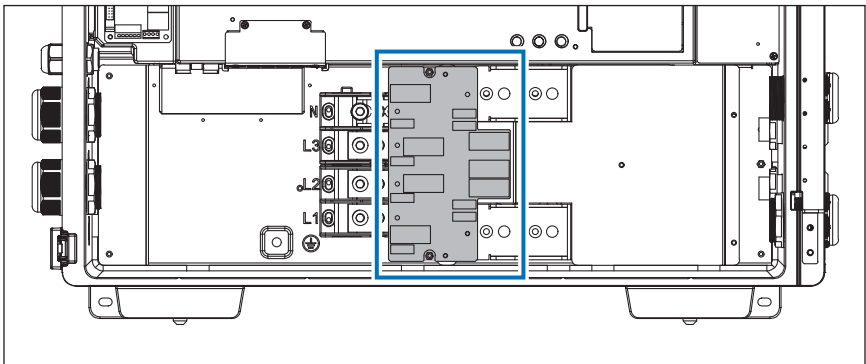

Figure 5-5: Remove the protective cover

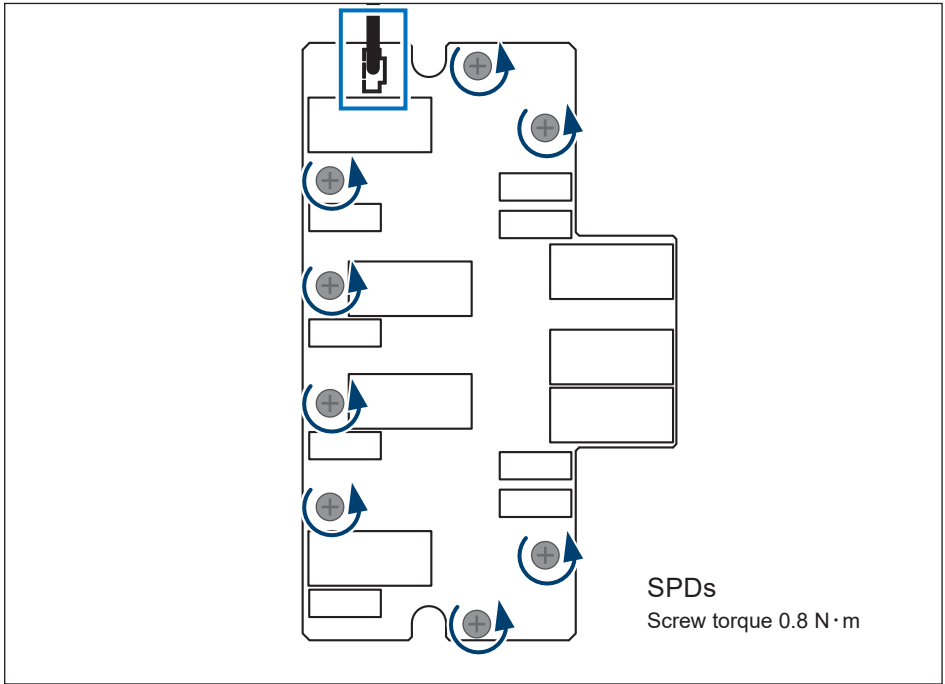

Figure 5-6: Remove sensing cable and screws

5.3 Smart Fans Replacement and Filter Cleaning

M100_210 has one fan tray for power module cooling and two internal fans for inside air circulation as shown in **Figure 5-7 to 5-14**

- Power Module (PM) compartment
- Inside the inverter compartment

Figures 5-8 illustrates the PM fan location.

Figures 5-9, 5-10, 5-11 illustrates the internal fan 1 locations.

Figures 5-12, 5-13, 5-14 illustrates the internal fan 2 locations.

ATTENTION



Periodic fan and filter cleaning is required to insure long life and reliability.

- The time period between cleanings depends on the quality of the environment.
- Under normal duty use, Delta recommends smart fans and filters be cleaned every 4 months
- For very dusty locations, it may be necessary to clean the fans and filters quarterly or monthly.

The cooling fans feature modular designs that make their removal for cleaning or replacement a simple task. As a result, the replacement of fans is also smart.

DANGER : ELECTRICAL HAZARD!!



- Prior to beginning any maintenance procedures outside AC breaker and DC switch off to avoid risk of electrical shock!

5.3.1 Location of failure fan

If the Error-code comes "W11 - Fan Fail", please refer to the corresponding code shown on DSS and procedure in following chapters to remove the fan.

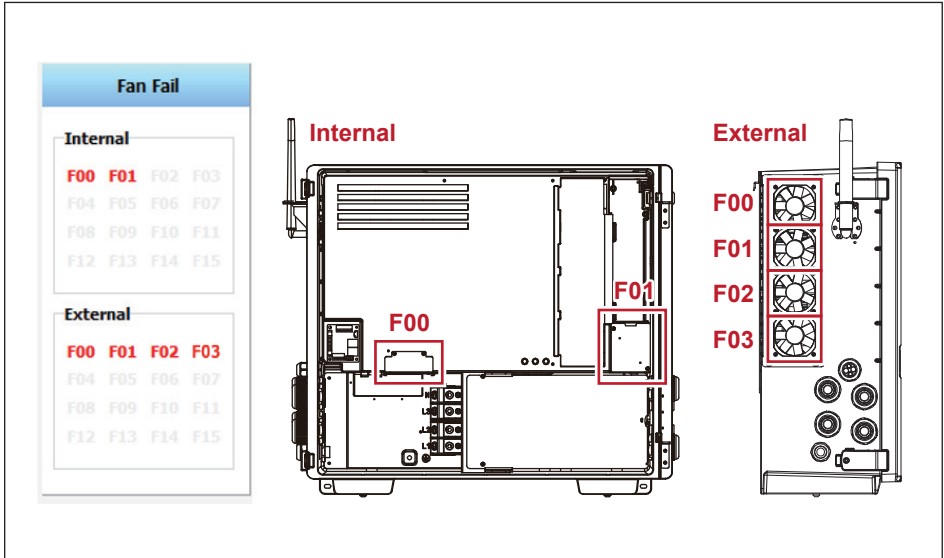

Figure 5-7: The corresponding fan location to the fan fail code on DSS

5.3.2 Power Module (PM) Fan Tray

Refer to **Figure 5-8** and follow the steps outlined below:

1. Remove four screws that secure inlet filter cover to case.
Check filter condition on this step and clean it if necessary.
For fan maintenance, continue to do following steps.
2. Unplug fan power connectors for each fan.
(To release snap-fit, press location A and location B from both side .)
4. Pull fan tray out from PM chassis.
To disassemble fan , remove four screws that secure it to fan tray.

To reassemble reverse the order of the above procedure and tighten screws to torque values indicated in **Figure 5-8**.

* Screw torque required for assembling:
1.4 N · m

1

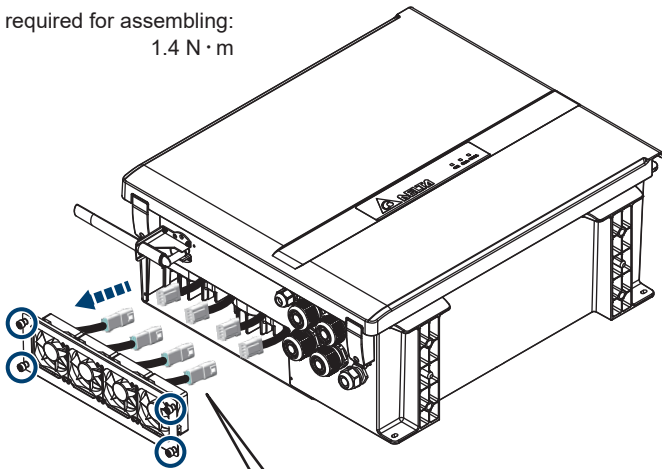

2

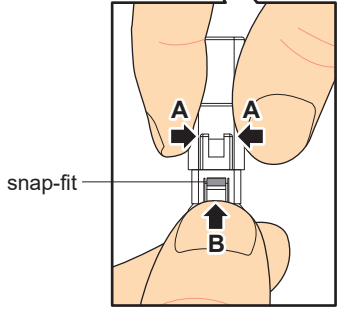

3

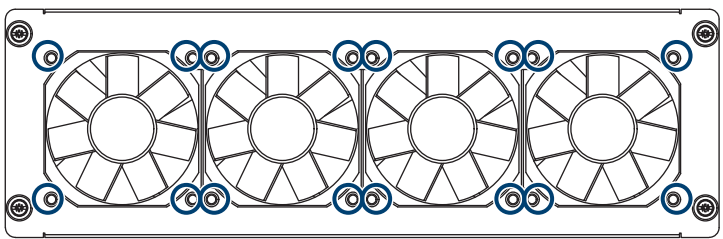

* Screw torque required for assembling: 0.6 N · m

Figure 5-8: Disassembling fan tray from PM chassis

5.3.3 Internal Fan 1

If the warning "**Fan Fail- Internal F01**" show on the DSS / APP, please follow the procedure below to remove Internal Fan 1.

- (1) Remove the B cover. (**Figure 5-9**)
- (2) Disconnect the power connector on the LED board. (**Figure 5-9**)
- (3) Loose two self-retaining screws and remove the fan cabinet. (**Figure 5-10**)
- (4) Lift the entire fan assembly. (**Figure 5-11**)
- (5) Clean assembly or replace with a new fan.
- (6) Reassemble by using $0.8 \text{ N} \cdot \text{m}$ tightening torque.

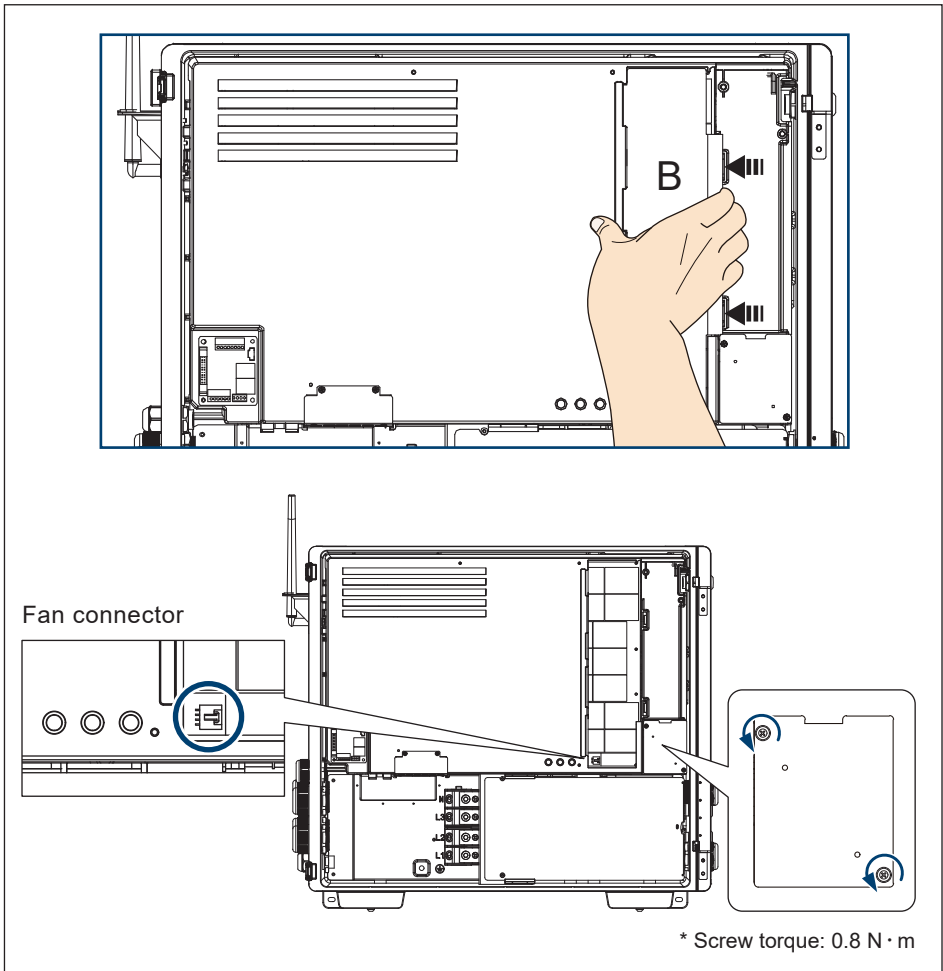

Figure 5-9: Internal fan 1 location & remove the shield cover

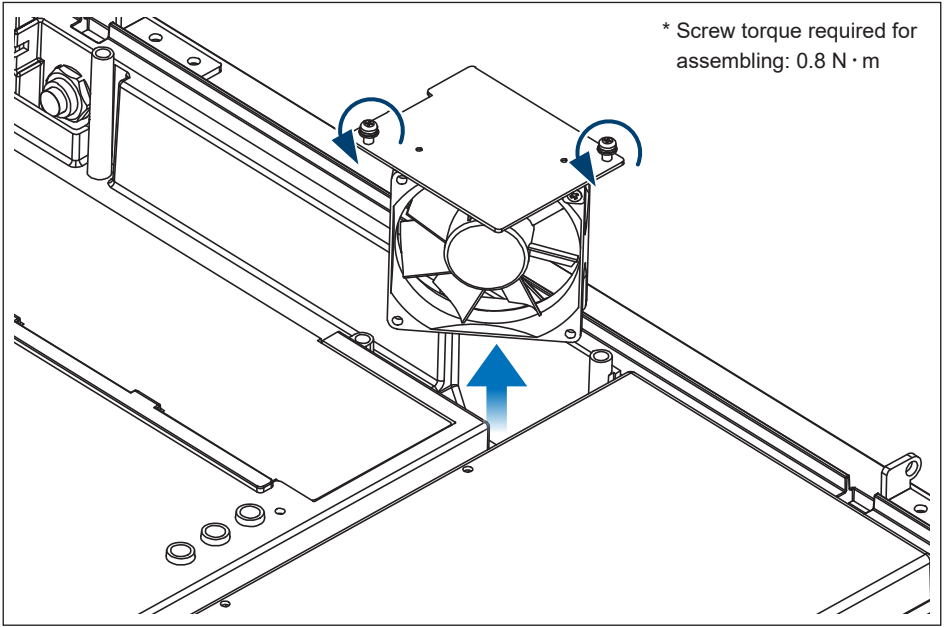

Figure 5-10: Take off the internal fan 1

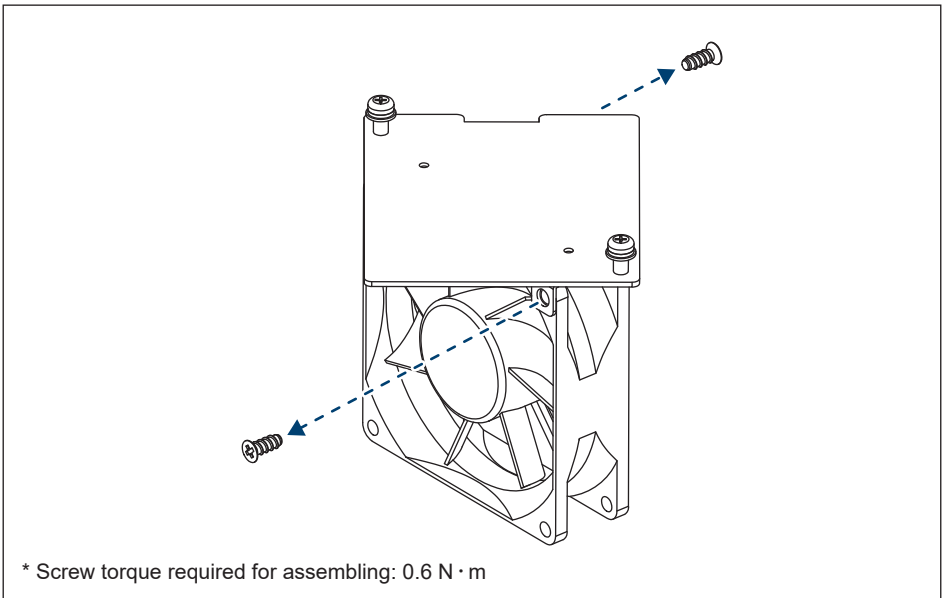

Figure 5-11: Replace with a new fan

5.3.4 Internal Fan 2

If the warning "**Fan Fail- Internal F00**" show on the DSS / APP, please follow the procedure below to remove Internal Fan 2.

- (1) Disconnect the power connector on the COMM. board. (**Figure 5-12**)
- (2) Loose 2 self-retaining screws and remove the fan cabinet. (**Figure 5-13**)
- (3) Lift the entire fan assembly. (**Figure 5-14**)
- (4) Clean assembly or replace with a new fan.
- (5) Reassemble by using $0.8 \text{ N} \cdot \text{m}$ tightening torque.

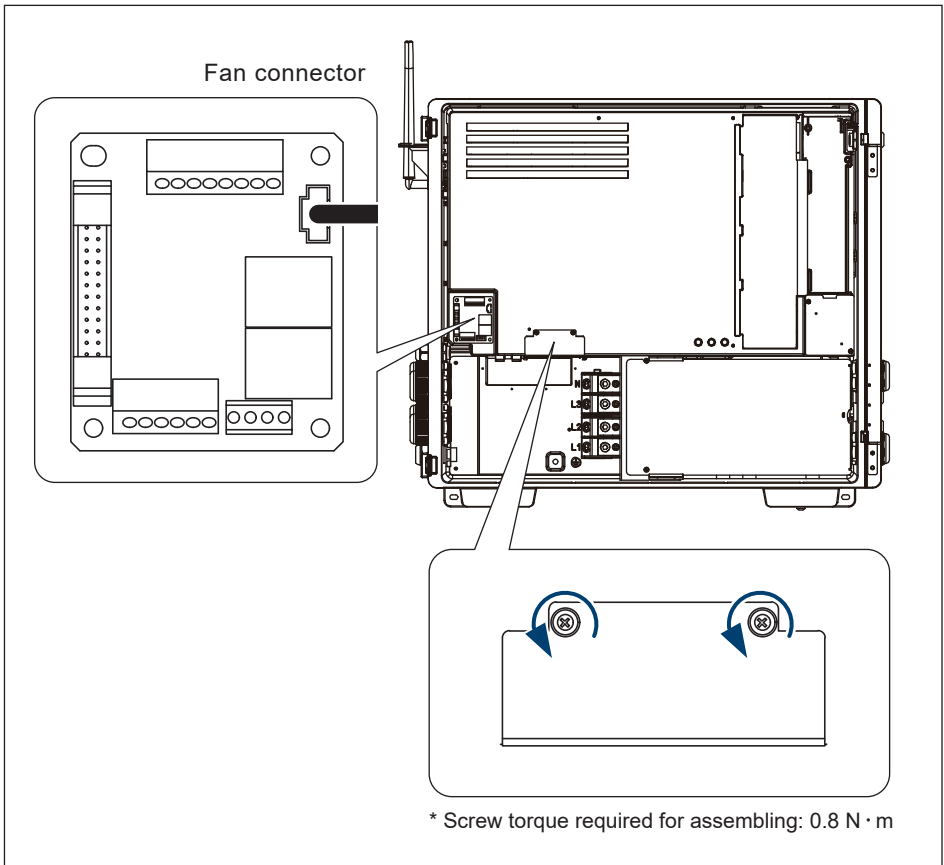

Figure 5-12: Internal fan 2 location & remove the shield cover

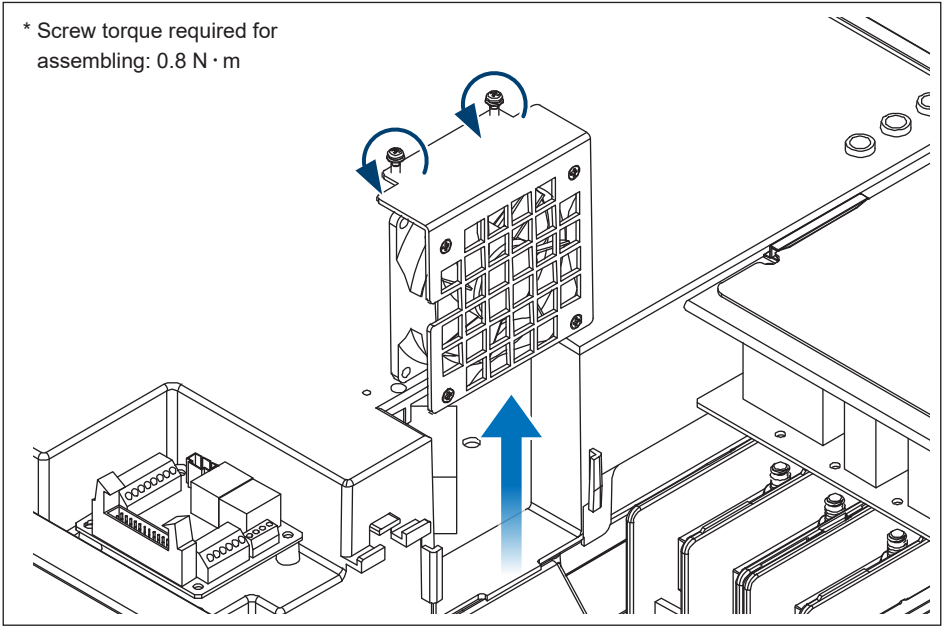

Figure 5-13: Take off the internal fan 2

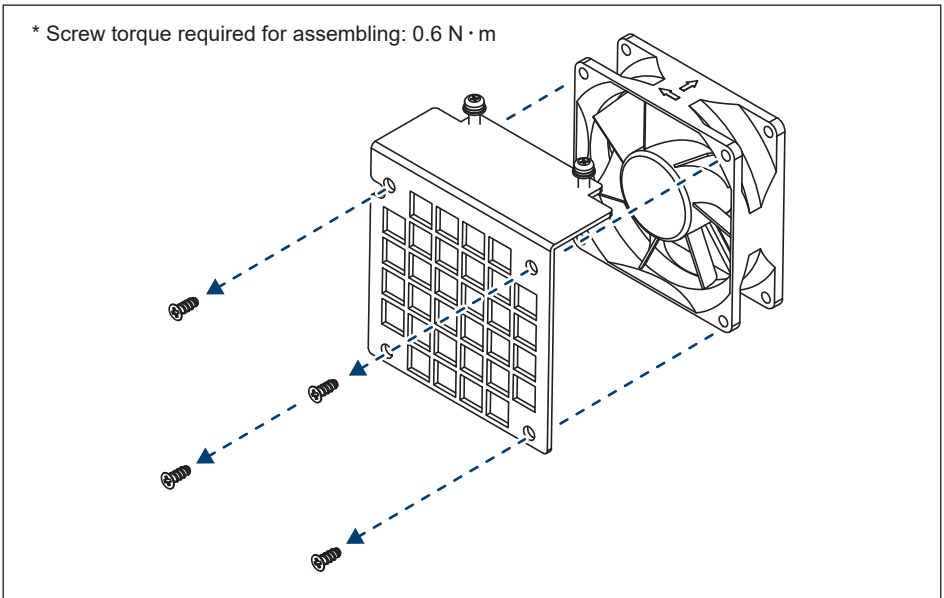

Figure 5-14: Replace with a new fan

5.4 De-Commissioning

DANGER : ELECTRICAL HAZARD!!



- Ensure DC and AC cables are always de-energized during De-commissioning to avoid Shock Hazard!

CAUTION : HOT SURFACES



- The surface of the inverter may be hot to cause injury, ensure the temperature is in the proper range before De-commissioning.

The procedure of M100_210 de-commissioning:

1. Follow **Section 5.1.1** to disconnect from the grid.
2. Follow **Section 5.1.2** to open the door.
3. Remove communication, DC, AC and Internal PE cables from terminals.

ATTENTION



- All cable conductors have to seal well with high insulation material.

4. Put stopper into the each hole of inner rubber and fasten well for sealing.

6 Error Message and Trouble Shooting

While Delta Electronics endeavors to build electronic products with high reliability standards, there may still be situations where the inverter may not operate properly. In this case, please follow the instructions in the “Troubleshooting Guide” (**Tables 6-1 ~ 6-4**) to attempt to clear the fault. If the problem can't be solved, please contact customer service for technical support.

6.1 Error Codes (Field Fault)

Table 6-1A: Error Codes (Field Fault) & Messages		
Message	Description	Action
AC Freq High (E01)	Grid frequency high	1. Check the utility frequency 2. Check Grid code & Grid setting
AC Freq Low (E02)	Grid frequency low	
Island (E03,E04,E05)	Islanding is detected	Check Grid breaker
AC phase jump (E06)	Phase jump of Grid voltage	If repeated occurrence, contact customer service for technical support
Grid Quality (E07)	Non-linear load in Grid and near to inverter	<i>If repeated occurrence, contact customer service for technical support</i>
AC phase abnormal (E08)	Wrong connection in AC plug	Check the AC connection in accordance with the user manual
No Grid (E09)	1. AC breaker is OFF 2. Disconnect in AC plug	1. Switch on AC breaker 2. Check the connection in AC plug and make sure it connects to inverter
AC Volt Low (E10)	1. Actual utility voltage is under the UVR setting 2. Incorrect Grid Code or Grid setting 3. Wrong connections in AC plug	1. Check the utility voltage within the suitable range 2. Check Grid code & Grid setting 3. Check the connection in AC plug
AC Volt High (E11)	1. Actual utility voltage is over the OVR setting 2. Incorrect Grid Code or Grid setting	
EPO (E25)	EPO is operated by user	Release the EPO button
DC Voltage High (E30)	Input voltage is over 1000Vdc	Modify the solar array setting, and make the Voc less than 1000Vdc
Insulation Fault (E34)	Insulation problem of PV array to ground	1. Check if panel enclosure ground completely 2. Check if inverter ground completely 3. Check if the DC breakers get wet
Remote OFF (E36)	Remote OFF by external communication	Check if remote OFF function is active

6.2 Fault Codes (Inverter Fault)

Table 6-2A: Fault Codes (inverter fault) & Messages

Message	Description	Action
DC Injection (F01,F02,F03,F04)	Utility waveform is abnormal	Contact customer service for technical support
Temperature High (F05)	The internal ambient temperature is over limit	Check the installation ambient and environment
Amb Temp Fault (F06)	Ambient temperature detection failure	Contact customer service for technical support
Temperature Low (F07)	The internal ambient temperature is under limit	Check the installation ambient and environment
Boost Temp Fault (F08)	Boost module temperature detection failure	Contact customer service for technical support
Bidir. Temp Fault (F09)	The boost/bidir. NTC temperature	Contact customer service for technical support
Inverter Temp Fault (F10)	Inverter module temperature detection failure	Contact customer service for technical support
AC RLY Fault (F13)	1. Defective relay driver circuit 2. Relay(s) failure	Contact customer service for technical support
FW Unmatch (F14)	Firmware Incompatibility	Contact customer service for technical support
AC Sensor Fault (F15)	Auxiliary power circuit failure	1. Check the polarity of PV connection (if the error code comes along with W08) 2. Contact customer service for technical support
Vdc Sensor Fault (F16)	DSP Vdc sensor circuit defective	Contact customer service for technical support
Idc Sensor Fault (F17)	Auxiliary power circuit failure	1. Check the polarity of PV connection (if the error code comes along with W08) 2. Contact customer service for technical support
AC Sensor Fault (F18)	Auxiliary power circuit failure	Contact customer service for technical support
Idc Sensor Fault (F19)	Auxiliary power circuit failure	Contact customer service for technical support
Red COMM Fault (F22)	The internal communication connection is disconnected	Contact customer service for technical support

Table 6-2B: Fault Codes (inverter fault) & Messages		
Message	Description	Action
DSP COMM Fault (F23)	The internal communication connection is disconnected	Check the connection interface RS-485
Ground Cur. High (F24)	Insulation problem of PV array to ground	1. Check the insulation of Solar inputs 2. Contact customer service for technical support
Iac Unbalance (F26)	1. Power line is disconnected 2. Current feedback circuit is defective	Check the connection in AC plug
RCMU Fault (F27)	RCMU circuit is disconnected	Contact customer service for technical support
AC RLY Short (F28)	Grid relay short	Contact customer service for technical support
AC RLY Open (F29)	Grid relay open	Contact customer service for technical support
Bus Unbalance (F30)	Voltage unbalance of DC link	Restart inverter by DC switch
Bus Voltage High (F31, F32, F33 F34, F35)	High bus capacitor voltage	1.Restart inverter by DC switch 2.Check the solar array setting, and make sure the Voc less than Max. Vdc of Inverter (if the error code comes along with E30)
AC Current High (F36,F37,F38 F39,F40,F41)	Surge occurs during operation	Contact customer service for technical support
AC CT Fault (F42,43,44)	Phase R / S / T CT is defective	Contact customer service for technical support
AC Current High (F45)	AC current over range	Restart the inverter by DC switches
ZC Circuit Fault (F50)	The zero crossing circuit is defective	Contact customer service for technical support
Inv Circuit Fault (F51)	The inverter circuit is defective	Contact customer service for technical support
Boost Circuit Fault (F52)	The boost circuit is defective	Contact customer service for technical support
Arc circuit fail (F58)	1. AFCI is not installed 2. AFCI self-test is fail	Check the AFCI detection circuit board for making sure it is connected correctly
Arc fault (F59)	The inverter detects arcing occurs	1. Check if there are any cable damaged at DC side. 2. Replace DC cable and unlock the Arc fault from DSS 3. Contact customer service for technical support

Table 6-2C: Fault Codes (inverter fault) & Messages

Message	Description	Action
DC Current High (F60,F61,F70,F71)	DC current over range	Restart inverter by DC switches
Ext COMM. Fault (F74)	The external communication connection is disconnected	1. Check the connection between external unit and COMM 2. Contact customer service for technical support

6.3 Warning Codes (Field Warning)

Table 6-3A: Warning Codes (Field warning) & Messages

Message	Description	Action
De-rating (W07)	<ol style="list-style-type: none"> Over temperature Power Limit function Power vs. Frequency function P(V) function Grid Voltage low Solar Voltage low Solar Voltage High Ramp up function 	<ol style="list-style-type: none"> Check the installation ambient and environment Check Grid Code & Grid setting Check the utility frequency on the inverter terminal Check the utility voltage on the inverter terminal 5-1. Check the utility voltage on the inverter terminal 5-2. Check reactive power setting Check the Solar voltage on the inverter terminal Check the Solar voltage on the inverter terminal Check Ramp up setting
String fault (W08)	<ol style="list-style-type: none"> Polarity of DC connectors is incorrect String current monitoring function is fail 	<ol style="list-style-type: none"> Check the polarity of PV connection Restart DC switch and AC breaker Contact customer service for technical support
String Current Low (W23)	Disconnection in DC connectors	<ol style="list-style-type: none"> Check String Connector and Fuse Contact customer service for technical support

6.4 Warning Codes (Inverter Warning)

Table 6-4A: Warning Codes (inverter warning) & Messages

Message	Description	Action
Fan Fail (W11)	<ol style="list-style-type: none"> One or more fans are locked One or more fans are defective One or more fans are disconnected 	Contact customer service for technical support
DC SPD Fault AC SPD Fault (W17) (W18)	<ol style="list-style-type: none"> One or more SPD are defective One or more SPD are disconnected 	<ol style="list-style-type: none"> Replace the defective SPD Check the connections of SPDs
Boost Circuit Fault (W30)	The boost circuit defective	Contact customer service for technical support

7 Technical Information

Table 7-1A: Specifications	
Model	M100_210
DC Input	
Occasionally Max. voltage	1100 V *1
Operating Voltage Range	570 - 1000 V
MPP Voltage Range @ AC 400V	590 - 860 V *2
Start Voltage	610 V @ AC 400V / 585 V @ AC 380V
Nominal DC Voltage	570 V
Max. Operating Current	185 A
Max. Input Power	113.5 kW
Max. Short Current Capability (Isc)	250 A
MPP Tracker	1
DC Connection Type	Terminal bus bar, Max. 185 mm ² Cu and Al conductor
Surge Protection	Type II SPD (built-in) ; Type I+II SPD (optional)
Arc Fault Detection	Built-in
AC Output	
Max. Apparent Power	110 kVA when AC voltage ≥ 400 V *3 105 kVA when AC voltage is 380 V *4
Max. Actual Power	110 kW when AC voltage ≥ 400 V 105 kW when AC voltage is 380 V
Output Power	100 kW @ 50°C ; 110 kW @ 40°C
Max. Output Current	160 A
Nominal AC Voltage	AC 400 V, 3Ø3W or 3Ø4W
AC Voltage Range	80% to 130% of nominal AC voltage
Night Time Reactive Power	60 kVAR
Operating Frequency Range	50 / 60Hz ± 5Hz
Power Factor (Adjustable)	0.8 ind - 0.8 cap
Surge Protection	Type II SPD (built-in) ; Type I+II SPD (optional)
T.H.D	< 3% at Rated output current
AC Connection Type	Terminal block, Max. 185 mm ² Cu and Al conductor
Night Time Consumption *5	< 3.5 W

*1 Maximum Withstand is 1100Vdc. However, the inverter will stop operating when the PV voltage is above 1000Vdc.

*2 Ambient < 15°C: 570~860V ; Ambient < 30°C: 570~840V ; Ambient < 40°C: 570~760V

*3 Ambient Temperature < 33°C, DC Input Voltage < 840Vdc

*4 Ambient Temperature < 31°C, DC Input Voltage < 840Vdc

*5 With RS-485 communication

Table 7-1B: Specifications		
Model	M100_210	
Efficiency		
Peak efficiency	99.0 %	
Euro efficiency	98.7 %	
Information		
Communication Port	RS-485 (built-in) ; SUB_1G / Wi-Fi (optional)	
Regulation		
Grid Support	IEC 62109-1/-2 IEC 62116 EN 61000-6-2 VPC	IEC 61727 IEC 61683 EN 61000-6-3
General Data		
Operating Temp. Range	-25 to +60°C (Derating Above 50°C)	
Protection Level	IP66	
Operating Elevation	< 4000 m	
Cooling	Smart fan air cooling	
Noise	65.2 dBA @1m, Amb25°C	
Dimension (W x H x D)	699 x 629 x 264 mm	
Weight	67 kg	

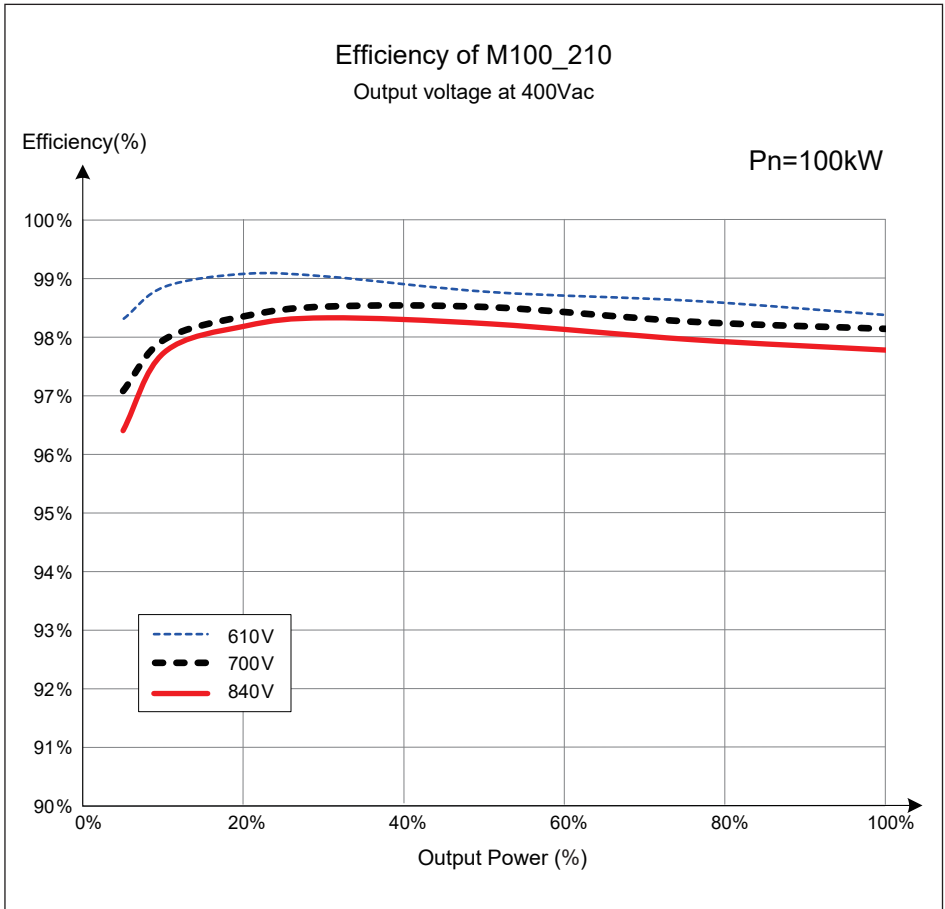

Figure 7-1: Efficiency Curve

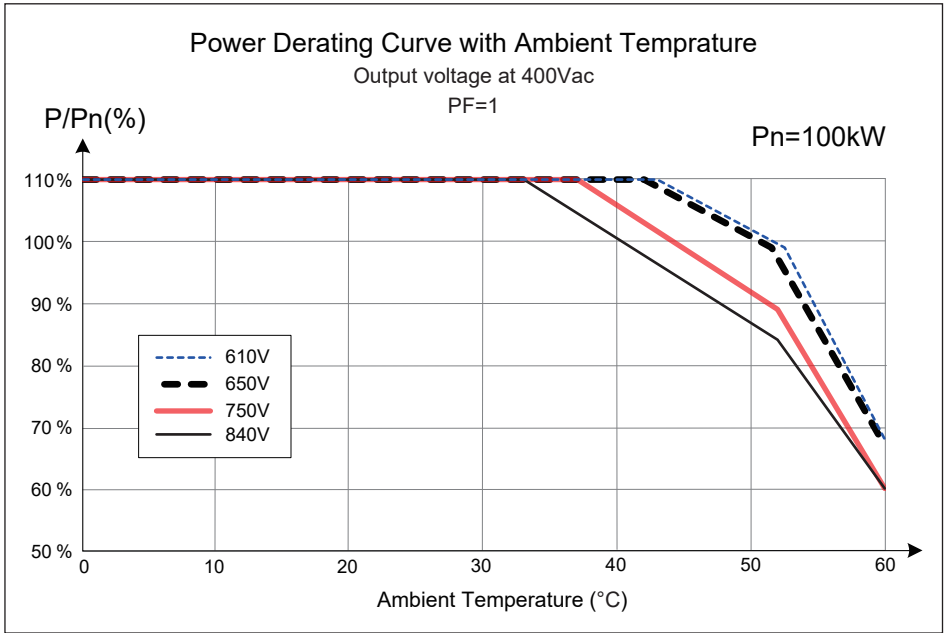

Figure 7-2: Power Derating Curve with Ambient Temperature (400 Vac)

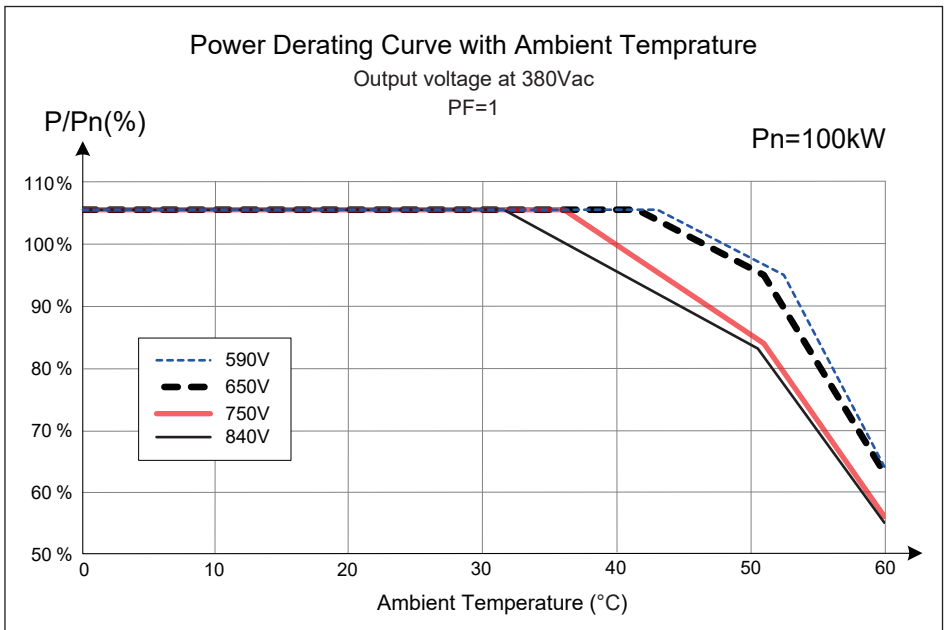

Figure 7-3: Power Derating Curve with Ambient Temperature (380 Vac)

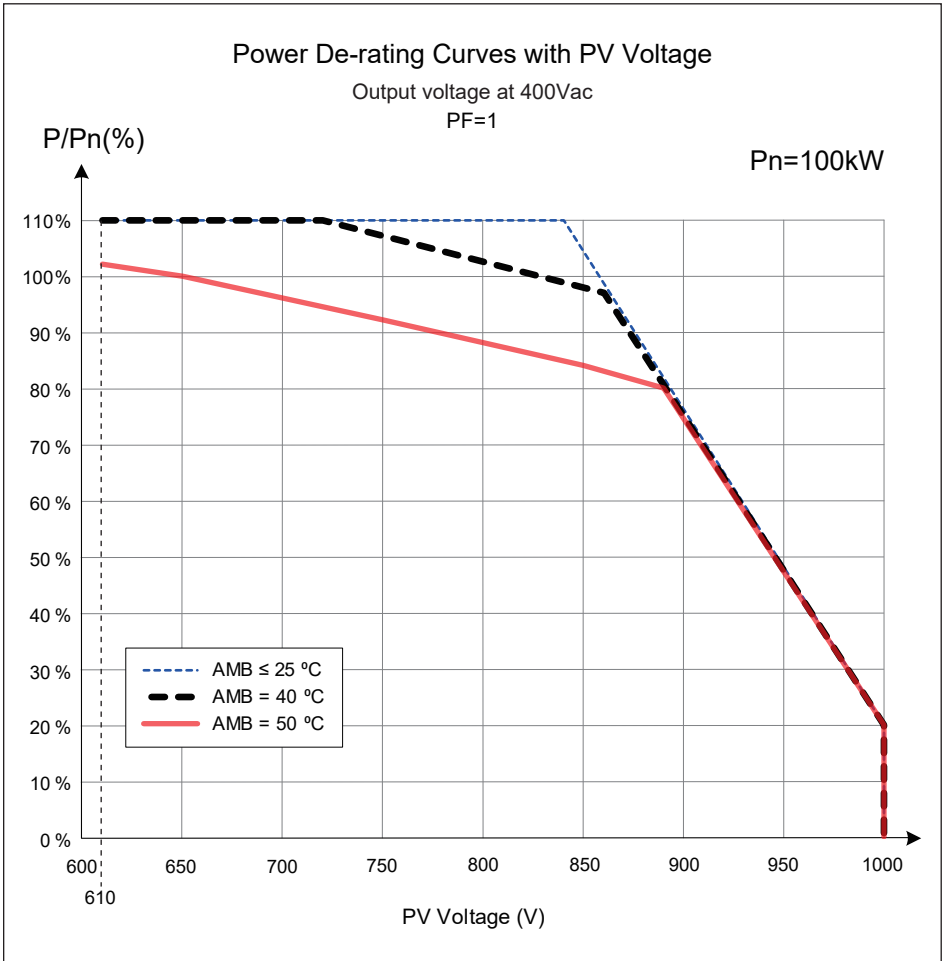

Figure 7-4: Power De-rating Curves with PV Voltage

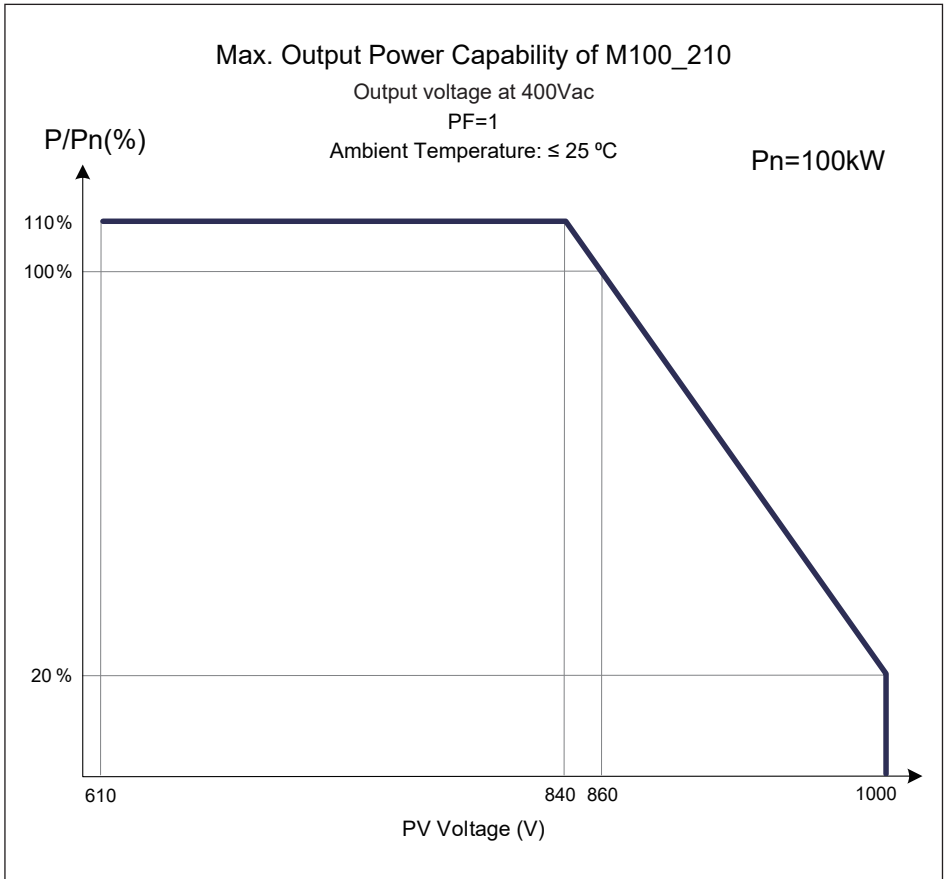
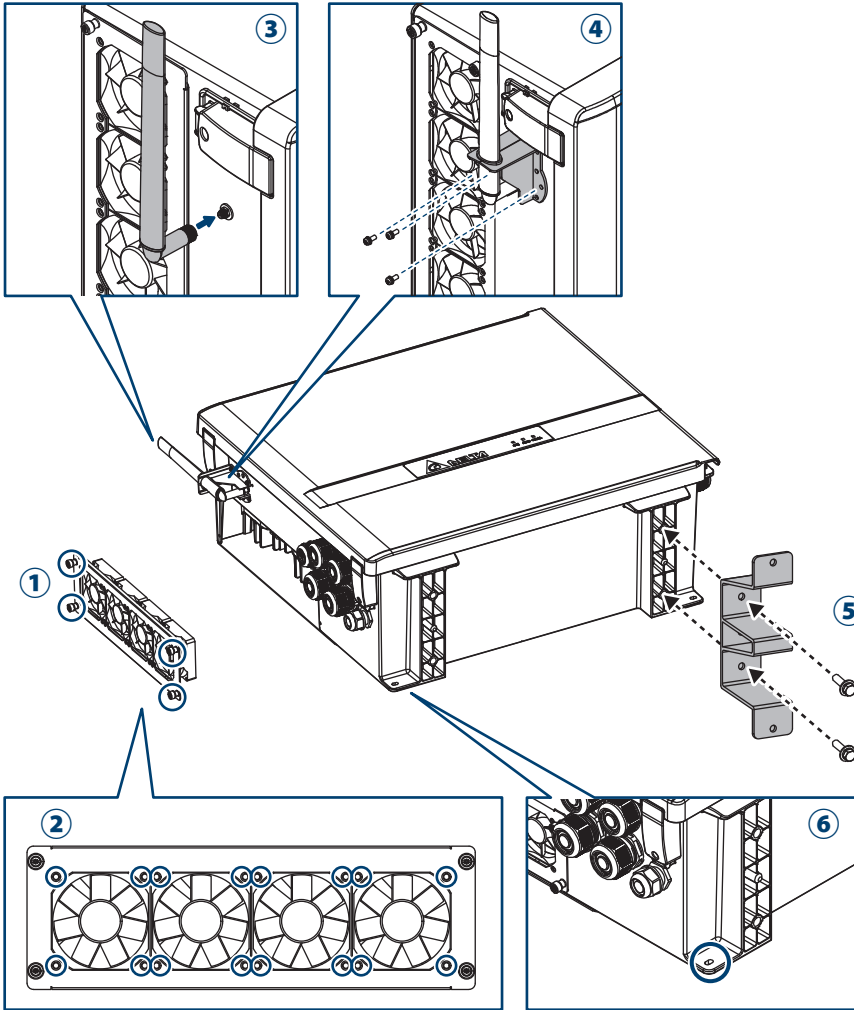

Figure 7-5: Max. Output Power Capability

Appendix: Assembly Note



Appendix-1: Assembly Note-1

NO	Location	Screw torque
1	Filter	14 kgf-cm (1.4N · m)
2	Fan Tray	6 kgf-cm (0.6N · m)
3	Antenna	12 kgf-cm (1.2N · m)
4	Antenna Bracket (M4)	10 kgf-cm (0.98N · m)
5	Grounded Bracket	250 kgf-cm (24.5N · m)
6	Grounding (M8)	102 kgf-cm (10N · m)

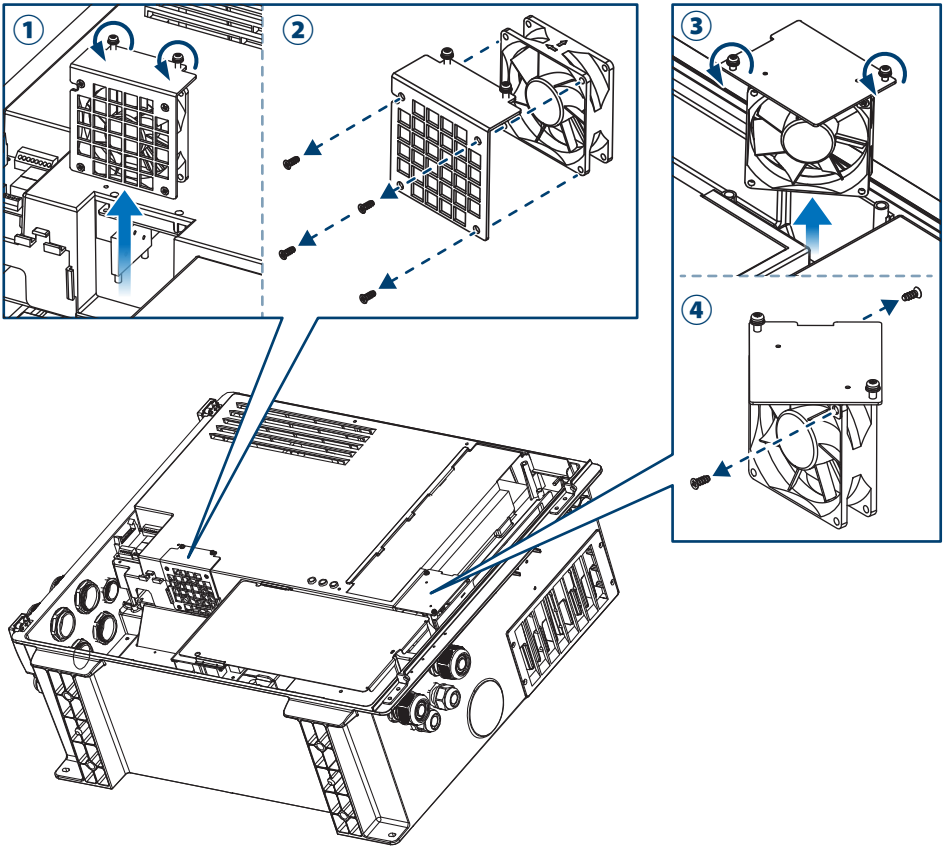

Appendix-2: Assembly Note-2

NO	Location	Screw torque
1	Internal Fan 2 Cover	8.0 kgf-cm (0.8N · m)
2	Internal Fan 2 Tray	6 kgf-cm (0.6N · m)
3	Internal Fan 1 Cover	8.0 kgf-cm (0.8N · m)
4	Internal Fan 1 Tray	6 kgf-cm (0.6N · m)

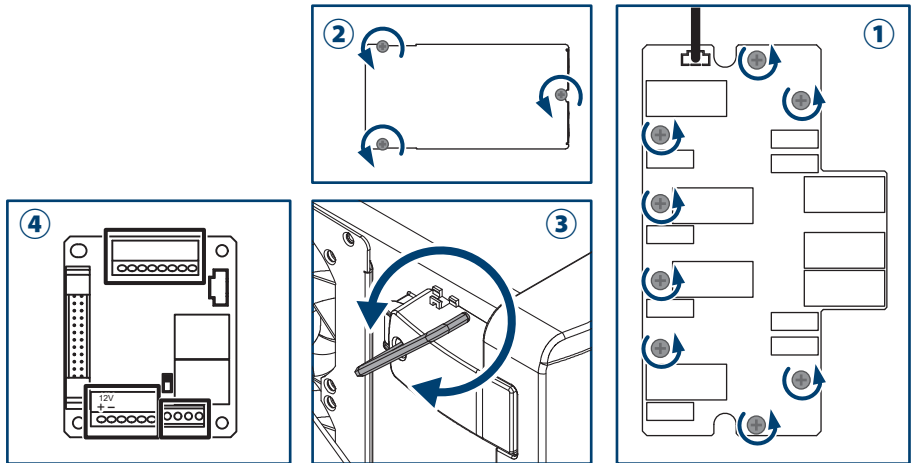
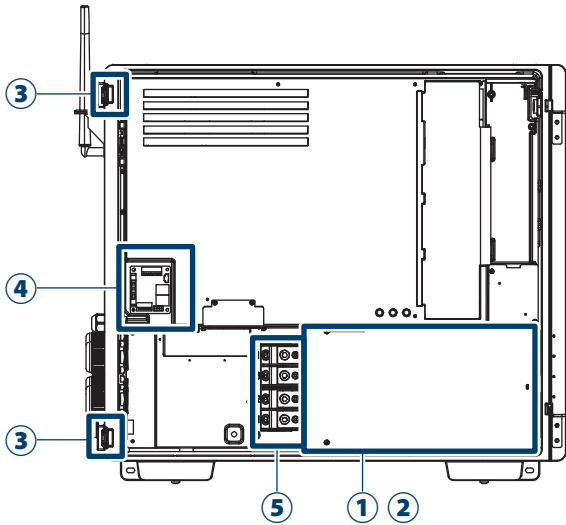

Appendix-3: Assembly Note-3

NO	Location	Screw torque	Conductor cross-section
1	SPD board	8.0 kgf-cm (0.8N · m)	-
2	AC Cover	8.0 kgf-cm (0.8N · m)	-
3	Toggle Latch	25 kgf-cm (2.45N · m)	-
4	Communication port	-	20 AWG (0.5mm ²)
5	AC terminal	L1, L2, L3, N	70mm ² ~185mm ²
		PE	120mm ²



三相併網型變流器

M100_210
操作手冊

English 1

繁體中文 83

www.deltaww.com

 **DELTA**
Smarter. Greener. Together.

Contents

1	安全規範	89
1.1	變流器資料	89
1.1.1	免責聲明	89
1.1.2	適用對象	89
1.2	安全概述	90
1.2.1	使用條件	90
1.2.2	標誌	92
2	產品介紹	93
2.1	適用機種	93
2.2	產品概述	94
3	安裝	98
3.1	拆箱與檢視	98
3.2	機構安裝	100
3.2.1	壁掛式安裝	101
3.2.2	落地式安裝 (選配)	106
3.3	佈線	108
3.4	交流配線安裝	110
3.4.1	AC 形式與連接方式	110
3.4.2	必要保護裝置	111
3.4.3	交流線材準備	111
3.4.4	接地線材準備	111
3.4.5	接地線安裝	112
3.4.6	交流配線	114
3.5	直流配線安裝	115
3.5.1	直流線材準備	115
3.5.2	直流電纜安裝	116
3.6	SUB_1G天線 (選配)	119
3.7	通信模組	122
3.7.1	RS-485 連線	124
3.7.2	EPO 緊急關斷功能與數位輸入	126
3.7.3	乾接點連接說明	127

4	試運行	128
4.1	控制面板介紹	128
4.2	自動ID設定	129
4.2.1	DSS連接	129
4.2.2	掃描變流器	130
4.2.3	ID設定	131
4.2.4	國別設定	132
4.2.5	時間同步設定	133
4.3	Delta功能設定	134
5	維護	135
5.1	開啟與關閉前蓋	135
5.1.1	斷電程序	135
5.1.2	開啟前蓋	135
5.1.3	關閉前蓋	138
5.2	更換雷擊保護裝置 (SPD)	139
5.2.1	移除雷擊保護裝置 (SPD)	140
5.2.2	安裝雷擊保護裝置 (SPD)	140
5.3	智慧風扇更換與濾網清潔	143
5.3.1	風扇告警對應位置	144
5.3.2	功率模組專用風扇	144
5.3.3	內部風扇1	146
5.3.4	內部風扇2	148
5.5	終止運轉	150
6	錯誤告警及排除問題	151
6.1	錯誤訊息(配置端故障)	151
6.2	故障訊息(變流器故障)	152
6.3	警告訊息(配置端警告)	154
6.4	警告訊息(變流器警告)	154
7	技術資料	155
	附錄: 組裝說明	161

Figure

圖 2-1: 內容物	94
圖 2-2: 外觀	95
圖 2-3: 標籤	96
圖 2-4: 配線箱架構圖	97
圖 3-1: 開箱步驟	98
圖 3-2: 搬動施力位置	99
圖 3-3: 正確的安裝位置	100
圖 3-4: 變流器尺寸	101
圖 3-5: 壁掛架尺寸	102
圖 3-6: 壁掛螺絲鎖附位置	103
圖 3-7: 壁掛所需間距	104
圖 3-8: 機台間最低要求距離	105
圖 3-9: 落地支架安裝	106
圖 3-10: 將變流器安裝在地面安裝基座上	107
圖 3-11: 佈線	108
圖 3-12: 交流側金屬管安裝配置	109
圖 3-13: 內部接地端配線	112
圖 3-14: 外部接地點	113
圖 3-15: 交流端配線	114
圖 3-16: 多層式防水塞蓋	116
圖 3-17: 滑動保護蓋	116
圖 3-18: 直流端配線 (單太陽能匯流箱)	117
圖 3-19: 直流端配線 (雙太陽能匯流箱)	118
圖 3-20: 天線安裝	119
圖 3-21: 安裝天線的注意事項	120
圖 3-22: 安裝天線支架	121
圖 3-23: 通信模組	122
圖 3-24: 通信模組位置圖	123
圖 3-25: 多台併接通訊示意圖	125
圖 3-26: 緊急關斷功能端子座	126
圖 3-27: 乾接點連接位置圖	127
圖 4-1: 顯示面板	128
圖 4-2: DSS連接	129
圖 4-3: 變流器掃描	130
圖 4-4: ID設定	131
圖 4-5: 國別設定	132
圖 4-6: 時間同步設定	133

圖 5-1: 開啟與關閉前蓋	136
圖 5-2: 利用扳手將前蓋進行固定	137
圖 5-3: 拆除前蓋	138
圖 5-4: 雷擊保護裝置	139
圖 5-5: 取下防護蓋	141
圖 5-6: 移除螺絲與排線	142
圖 5-7: DSS錯誤代碼對應之風扇位置	144
圖 5-8: 風扇架拆卸示意圖	145
圖 5-9: 內部風扇1 位置與拆裝示意圖	146
圖 5-10: 取下內部風扇1示意圖	147
圖 5-11: 更換風扇示意圖	147
圖 5-12: 內部風扇2 位置與拆裝示意圖	148
圖 5-13: 取下內部風扇2示意圖	149
圖 5-14: 更換風扇示意圖	149
圖 7-1: 效率曲線圖	157
圖 7-2: 環溫對應降額曲線圖(400 Vac)	158
圖 7-3: 環溫對應降額曲線圖(380 Vac)	158
圖 7-4: 環境溫度對應輸出能力降額曲線	159
圖 7-5: 環溫對應視在功率降額曲線圖	160

Table

表 2-1: 內容清單	94
表 2-2: 外觀介紹	95
表 2-3: 標籤內容描述	96
表 2-4: 配線箱架構圖內容描述	97
表 3-1: 交流斷路器之建議規格	110
表 3-2: 電纜線尺寸對照表	116
表 3-3: RS-485 端子座說明	124
表 3-4: 終端電阻設定說明	125
表 3-5: 數位輸入與EPO功能說明	126
表 4-1: LED 指示燈	128
表 4-2: LED 通訊指示燈	128
表 6-1A: 錯誤訊息(配置端故障)	151
表 6-2A: 故障訊息(變流器故障)	152
表 6-2B: 故障訊息(變流器故障)	153
表 6-3A: 警告訊息(配置端警告)	154
表 6-4A: 警告訊息(變流器警告)	154
表 7-1A: 規格	155
表 7-1B: 規格	156
附錄-1: 組裝說明-1	161
附錄-2: 組裝說明-2	162
附錄-3: 組裝說明-3	163

1 安全規範

1.1 變流器資料

1.1.1 免責聲明

著作權~ DELTA ELECTRONICS, INC. - All rights reserved.

本說明書及產品供終端使用者使用。技術資料及內圖文皆為機密資料且不經 DELTA ELECTRONICS, INC. 許可，禁止複製翻印。

維修工程師及終端使用者禁止洩漏內涵之訊息及除以正確使用本產品以外的目的使用本說明書。所有資訊若有變更，不另外通知。

DELTA ELECTRONICS, INC. 針對以下情形造成的損害將不負任何責任及義務：

- (a) 產品沒有恰當的安裝或維修
- (b) 產品未依照說明書正確使用
- (c) 產品於拆裝過程受損

1.1.2 適用對象

本說明書適用於針對安裝、試運行、實際操作、後續維護受過良好訓練的人以下基礎及進階技巧為必需的。

- 了解基礎電力、配線、電子元件及電子電路符號
- 了解太陽能變流器如何運行及操作
- 針對電子產品的安裝及試運行受過訓練
- 針對安裝及使用電子產品的過程中會遇到的危險及風險受過訓練
- 遵守本說明書及所有安全規範

開始接觸此產品前，請詳閱本說明書。

1.2 安全概述

重要安全指示：保存所有指示！



- 請詳閱所有指示及保存供後續使用。

為了避免人員受傷或其他損失及確保變流器長期運轉，在使用此產品前請務必詳閱所有安全指示。

本說明書針對DELTA併網型無變壓器太陽能變流器提供重要指示。本產品進行設計、測試、驗證且經國際安全規範認證，安裝及使用本產品前仍須做好防範措施。本產品適用於室內及戶外。

注意：無電氣隔離



- 本產品無附加變壓器，為非電氣隔離型。
請勿使用需接地(正極或負極)之太陽能板。
若使用了，則本產品會以INSULATION (E34) 告警。
- L1, L2, L3,及 N 禁止連接至地。

1.2.1 使用條件

- M100_210 為 1 MPP追蹤、無變壓器太陽能變流器，能將太陽能串列的變動電流轉換成與市電頻率相同之三相交流能量並饋入市電。
- 所使用之太陽能模組需與變流器匹配。
- 太陽能面板之對地電容不可超過 10 μ F。
- 工業環境使用
- 本產品僅可在經DELTA及市電業者許可之國家運行。

1.2.2 標誌

本節說明本說明書會出現的標誌定義，為了避免人員受傷或其他損失及確保變流器長期運轉，在使用此產品前請務必詳閱所有安全指示並遵守。

危險！



- 此警語表示可能發生致死或嚴重傷亡的情形。

警告！



- 此警語表示可能發生致死或嚴重傷亡的情形。

注意！



- 此警語表示可能發生較輕微傷害的情形。

注意



- 此警語表示可能對資產或環境造成傷害。

資訊



- 進一步的資訊會經由雙圈驚嘆號指示。
這代表接續的內容將含有使用者該遵守的重要資訊以免造成任何傷害。

危險：觸電!!



- 此警語表示可能會有造成嚴重傷亡的觸電可能。

注意：表面高溫，請勿觸碰！



- 此警語表示當變流器運行時機體表面高溫，
待表面溫度下降後在進行需接觸的工作。



- 等待圖示中所顯示的時間後再進行工作



- 設備接地導體

2 產品介紹

M100_210 以最先進之高頻切換及低EMI技術設計而成，同時具有高效率及高壽命的特點，亦適用於戶外。

注意：無電氣隔離



- 本產品無附加變壓器，為非電氣隔離型。
請勿使用需接地(正極或負極)之太陽能板。
若使用了，則本產品會以INSULATION (E34) 告警。
- L1, L2, L3,及 N禁止連接至地。

注意：適用於工業環境



- 本產品符合IEC 62910 : 2017 Class A規範，其電磁干擾保護能力適用於商業應用情況。
- 本產品會產生符合工業環境規範內之射頻輻射，請遵循說明書指示安裝與使用。
- 於家用環境使用本產品可能造成電磁干擾危害。

2.1 適用機種

本說明書適用以下機種:

- M100_210

安裝、運行及維護過程皆必須遵守本說明書。

DELTA保留在不另行告知的前提下修改內容及技術資料的權力。

2.2 產品概述

內容物如圖2-1所示。



圖2-1：內容物

表2-1：內容清單

M100_210			
	物件	數量	描述
1	DELTA太陽能變流器	1	太陽能變流器
2	說明書	1	安裝及維運過程中務必參考本說明書中的安全指示
3	壁掛架	1	將變流器掛起之壁掛架 (材質: 鋁 / 厚度: 3mm)
4	六角板手 (已安裝於鎖扣外蓋上)	1	固定前蓋用門門與卸除鎖扣外蓋螺絲工具

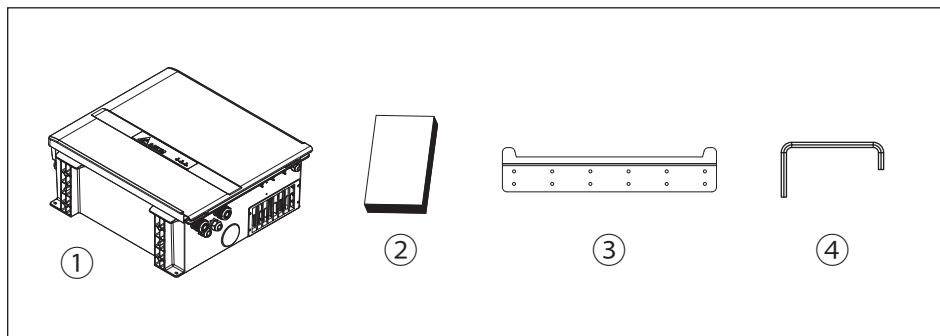

圖 2-2 : 外觀

表2-2 : 外觀介紹

NO.	Component	NO.	Component	NO.	Component
1	External fans	2	Toggle Latch	3	SUB_1G antenna*
4	Port for Wi-Fi antenna*	5	Air cooling outlet	6	M25 gland for PE wiring
7	4x M40 glands for AC Output	8	Cable gland for communication wiring	9	External grounding point
10	LED Indicators	11	2x M40 glands for DC Input	12	2x M25 glands for DC Input

* SUB_1G / Wi-Fi 天線為選配部件，相關資訊請聯繫客服中心

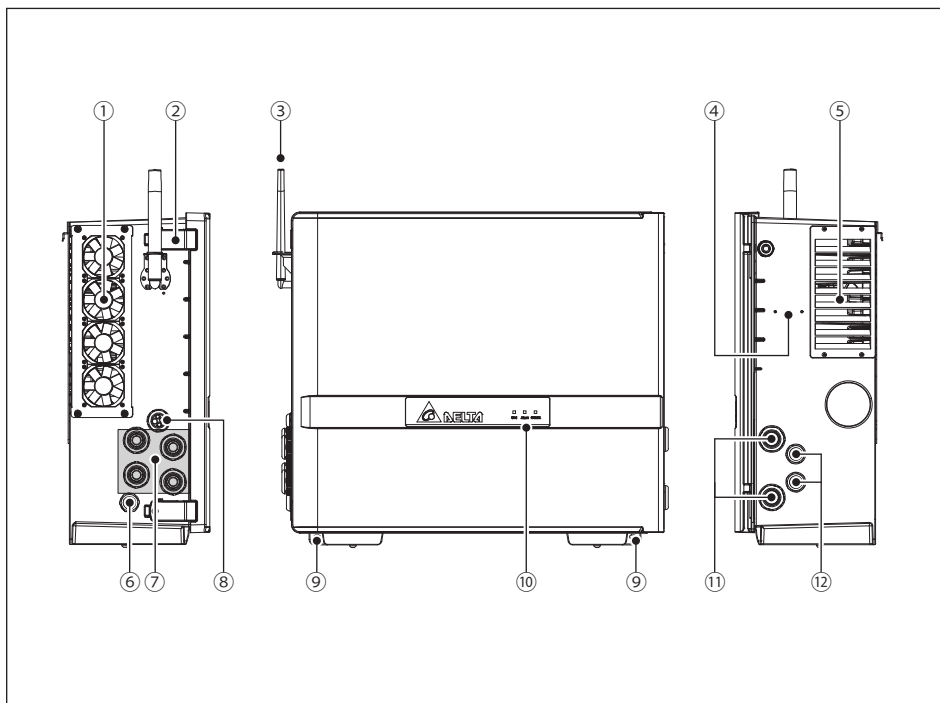
圖2-3為產品標籤並配合表2-3針對特殊符號做解釋。



圖2-3：標籤

表2-3：標籤內容描述





符號	定義
 60 seconds	嚴重觸電危險 變流器運行時會有致命高電壓存在，切斷後危險電壓存在約60秒，時間內請勿接觸變流器。 本產品不含任何需要開啟機殼之元件。擅自開啟機殼會使保固失效。
	此變流器本身沒有經由變壓器與市電端分離。
	若當地規範要求，機體外殼請務必下地。
	WEEE marking 本變流器須以標準家用廢棄物報廢，並同時遵守當地針對電器報廢的相關規範。
	使用此變流器前，請詳閱說明書。

圖2-4為配線箱的架構圖，詳細描述可參照表2-4。



圖2-4：配線箱架構圖

表2-4：配線箱架構圖內容描述

NO.	Component	NO.	Component	NO.	Component
1	Communication module	2	Internal fan 2	3	Internal fan 1
4	Internal grounding point	5	AC terminal	6	Type II SPD
7	DC out busbar (-)	8	DC out busbar (+)		

3 安裝

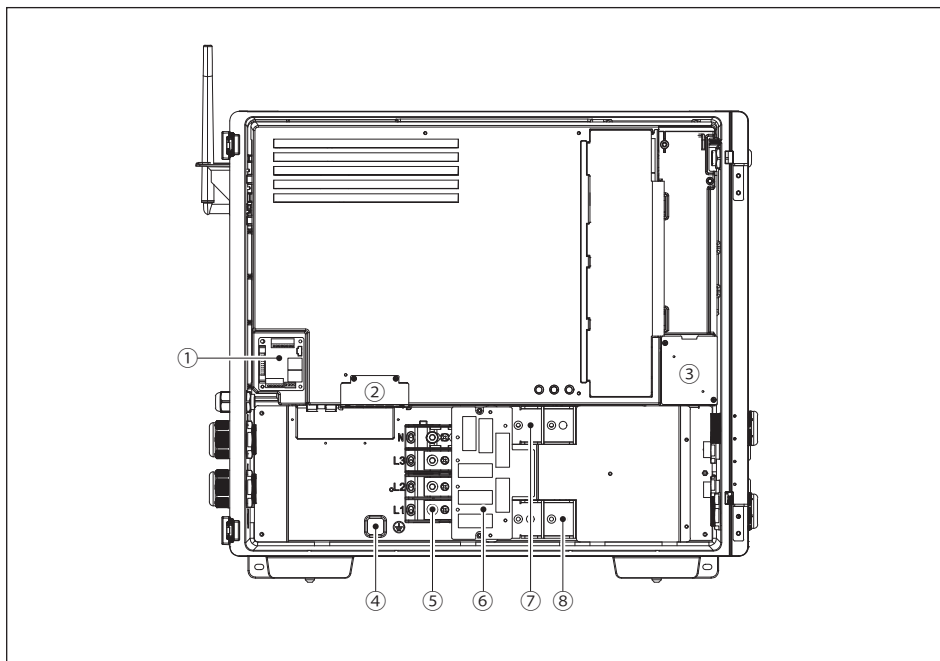
本章節包含以下指示

1.機構安裝 2.電氣安裝 3.通訊安裝

3.1 拆箱與檢視

請依照圖 3-1所示拆封外箱包裝。

建議兩人以上進行作業(圖 3-2)。



圖 3-1: 開箱步驟

注意！



- 針對站立式安裝，建議腳架於開箱步驟時進行安裝，請參考3.2.2章節。
- 建議兩人以上進行扶正作業。

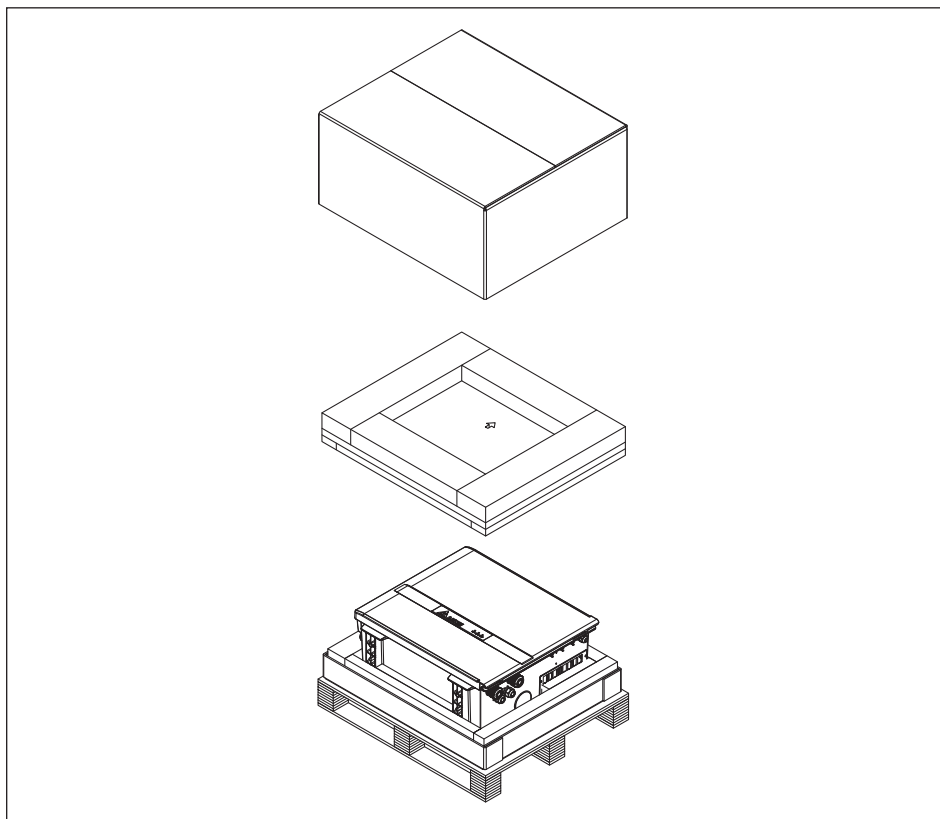

圖 3-2: 搬動施力位置

3.2 機構安裝

M100_210僅支援垂直安裝，傾斜誤差允許範圍如圖3-3所示。

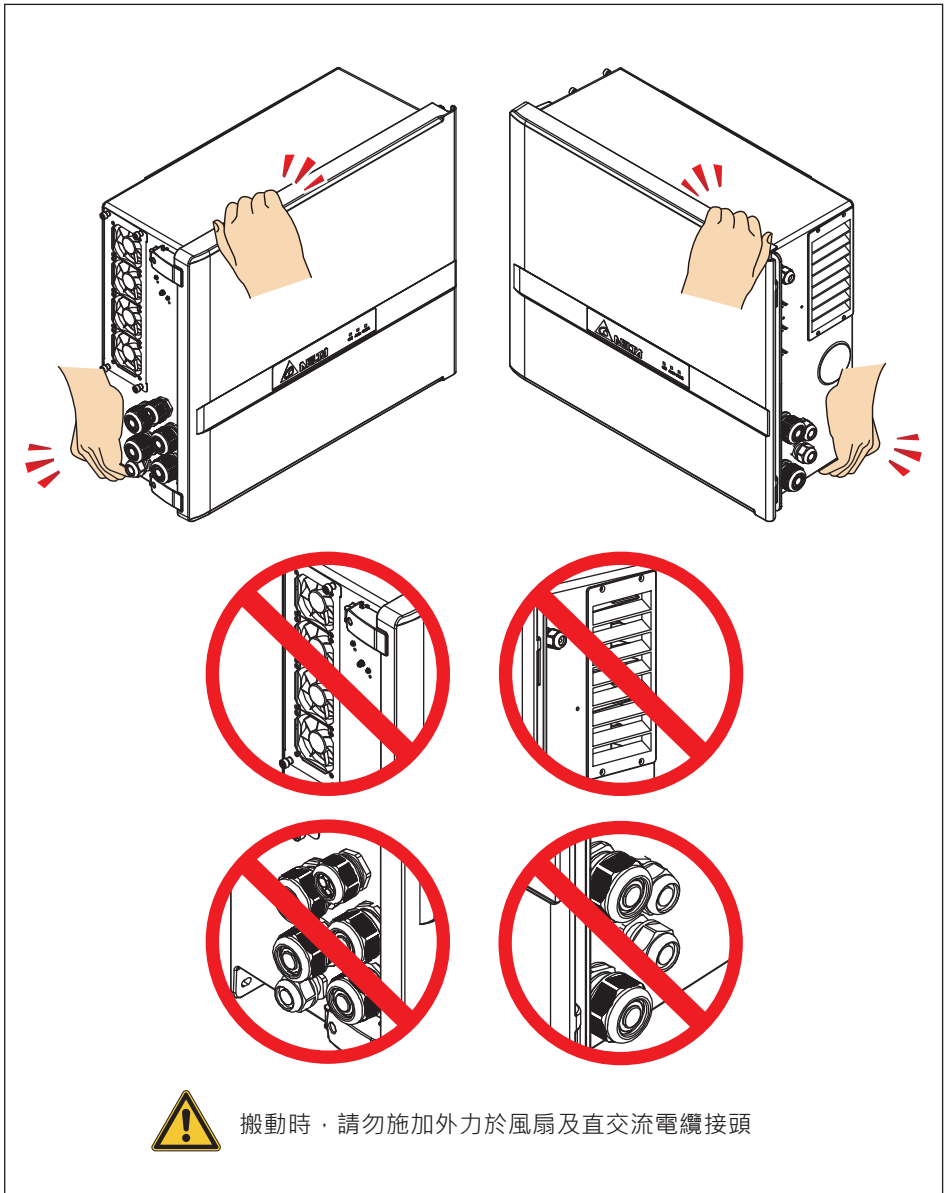

圖 3-3: 正確的安裝位置

注意！



為避免由於極端氣候(大雪, 冰雹...等)或不恰當的安裝/維運所導致的變流器故障, 台達強烈建議安裝額外的保護蓋。詳細細節請洽當地服務團隊。

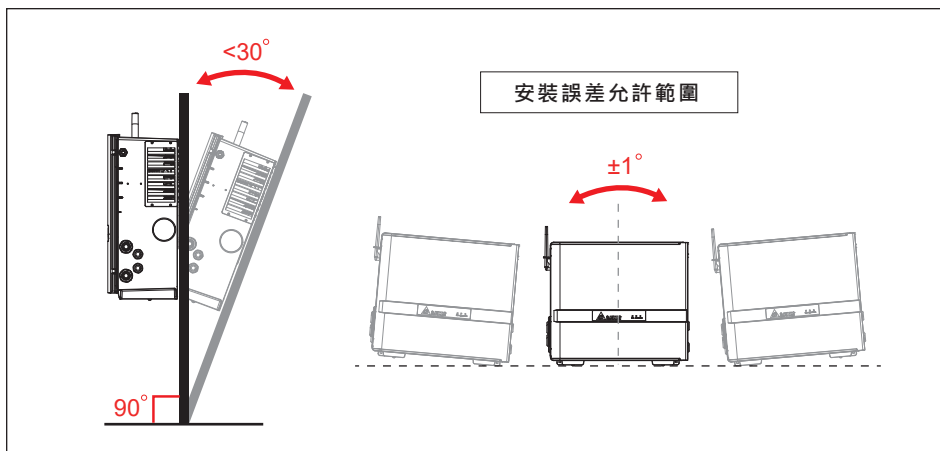
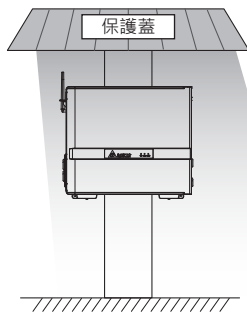

警告！



- 請勿將本產品安裝在易燃表面附近。
- 請將本產品安裝於堅固且平順之表面。

3.2.1 壁掛式安裝

請參考圖3-4至3-8說明

1. 請先確定產品安裝牆面為足以承載產品重量。
2. 水平固定壁掛架(垂直於地板)·壁掛架尺寸如圖3-5所示。
3. 鎖附12枚M6十字螺絲於壁掛架上。(圖3-6)
4. 將產品放置於壁掛架上。
5. 以兩枚M8螺絲·透過圖3-6所示之外部接地點鎖附變流器於牆面。

注意！



- 至少使用8枚M6螺絲將壁掛架固定牆上。
- 該壁掛架為本產品專用·請勿使用其他壁掛架來搭配本產品使用。
- 未遵守以下安裝說明中的方向和間隙可能導致降額功率輸出並可能使保固失效。



圖 3-4: 變流器尺寸



圖 3-5: 壁掛架尺寸

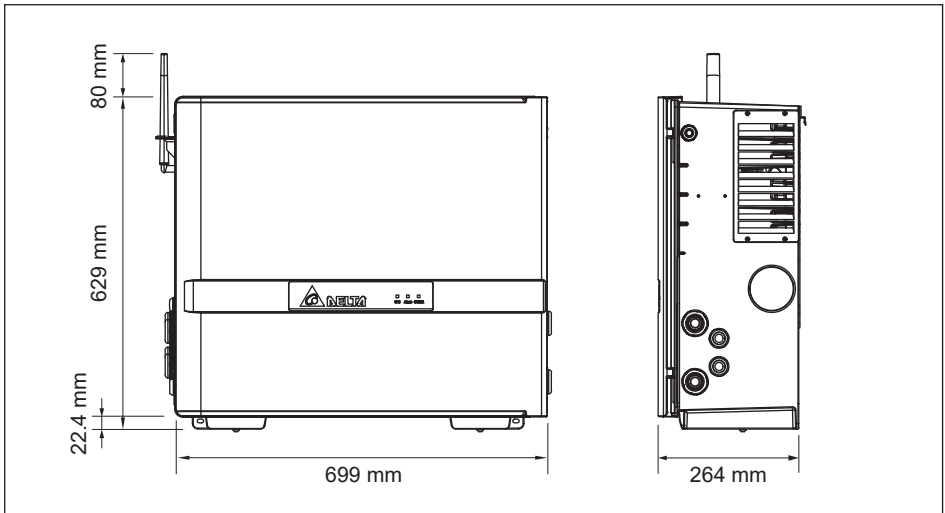

圖 3-6：壁掛螺絲鎖附位置

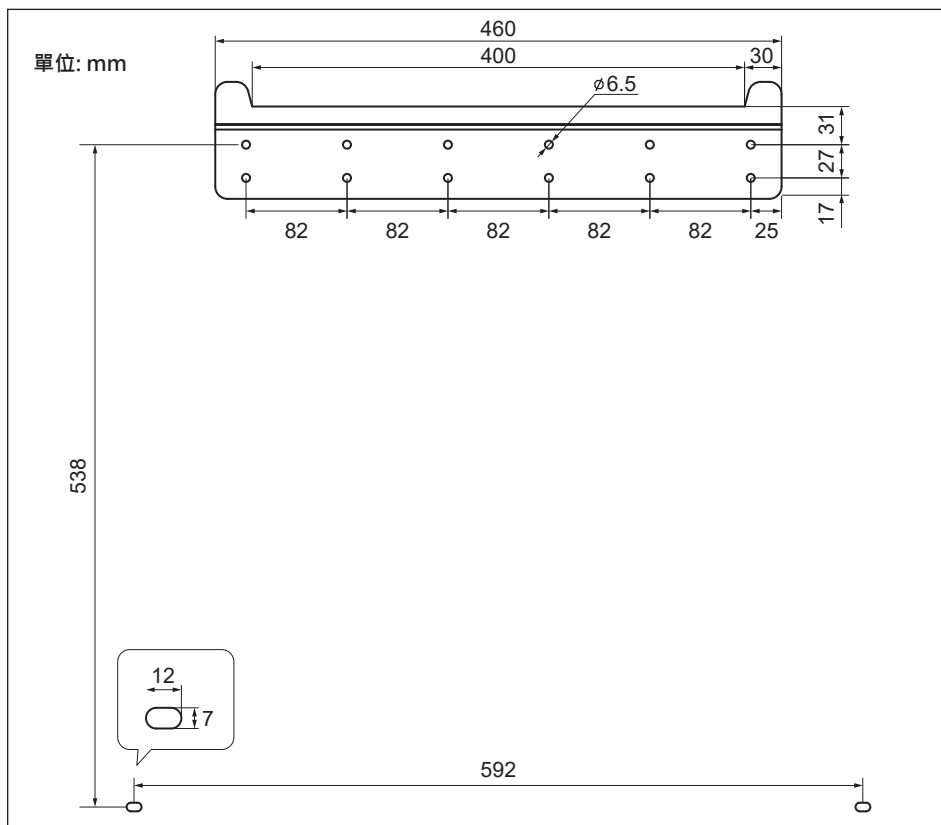

圖 3-7: 壁掛所需間距

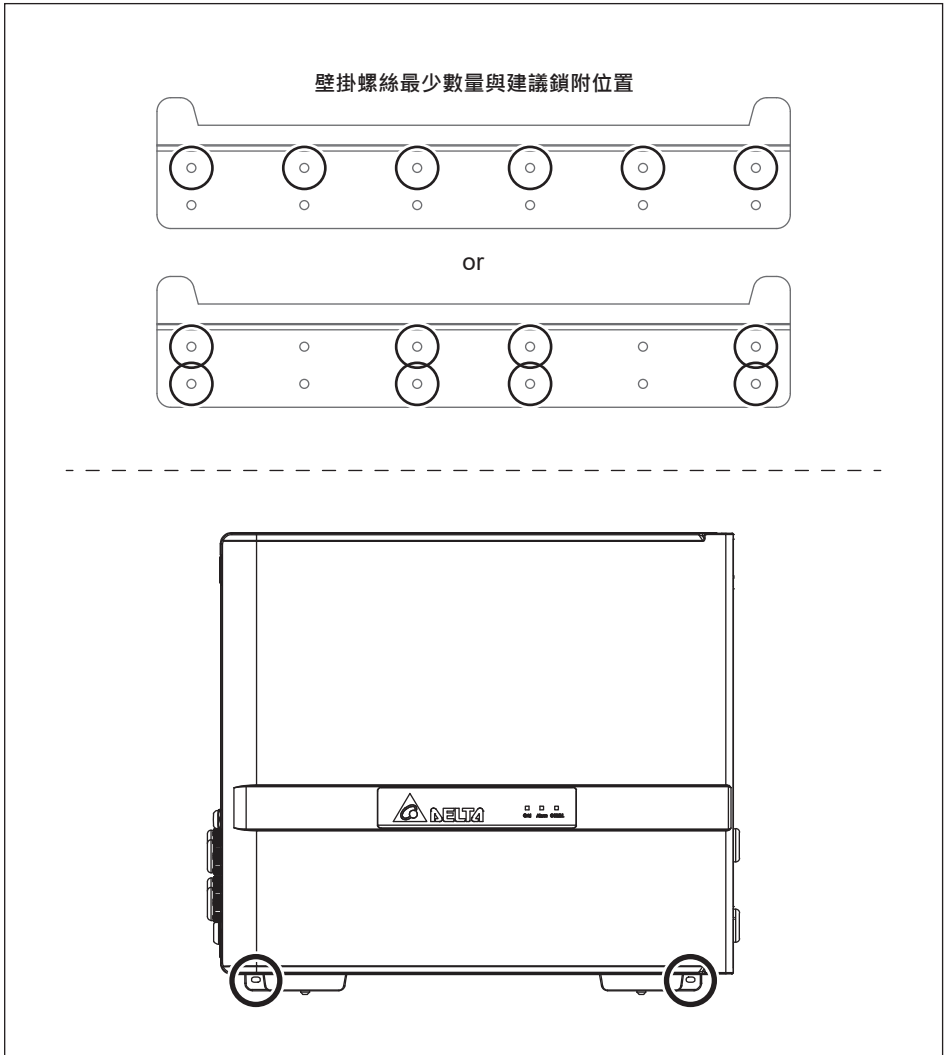

圖 3-8: 機台間最低要求距離

3.2.2 落地式安裝 (選配)

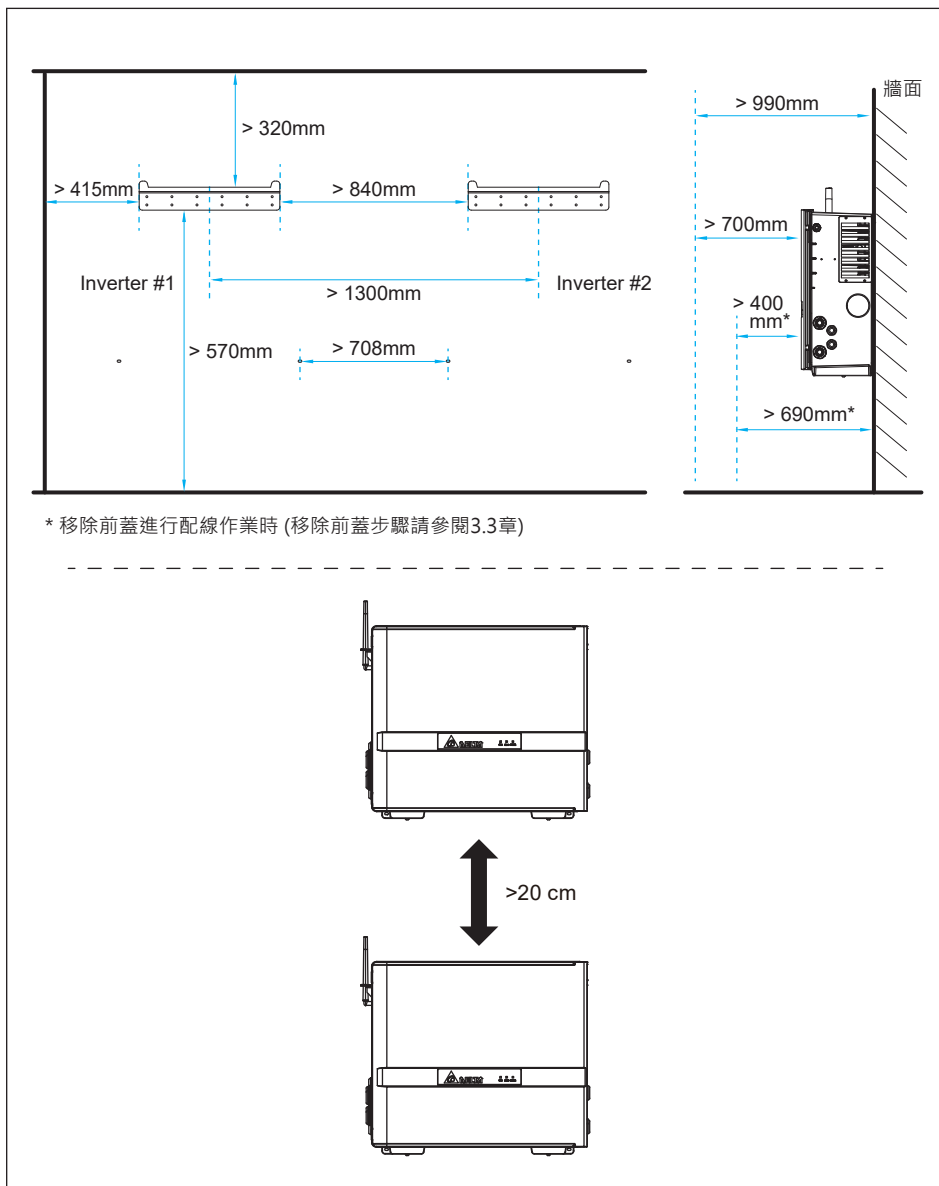
注意

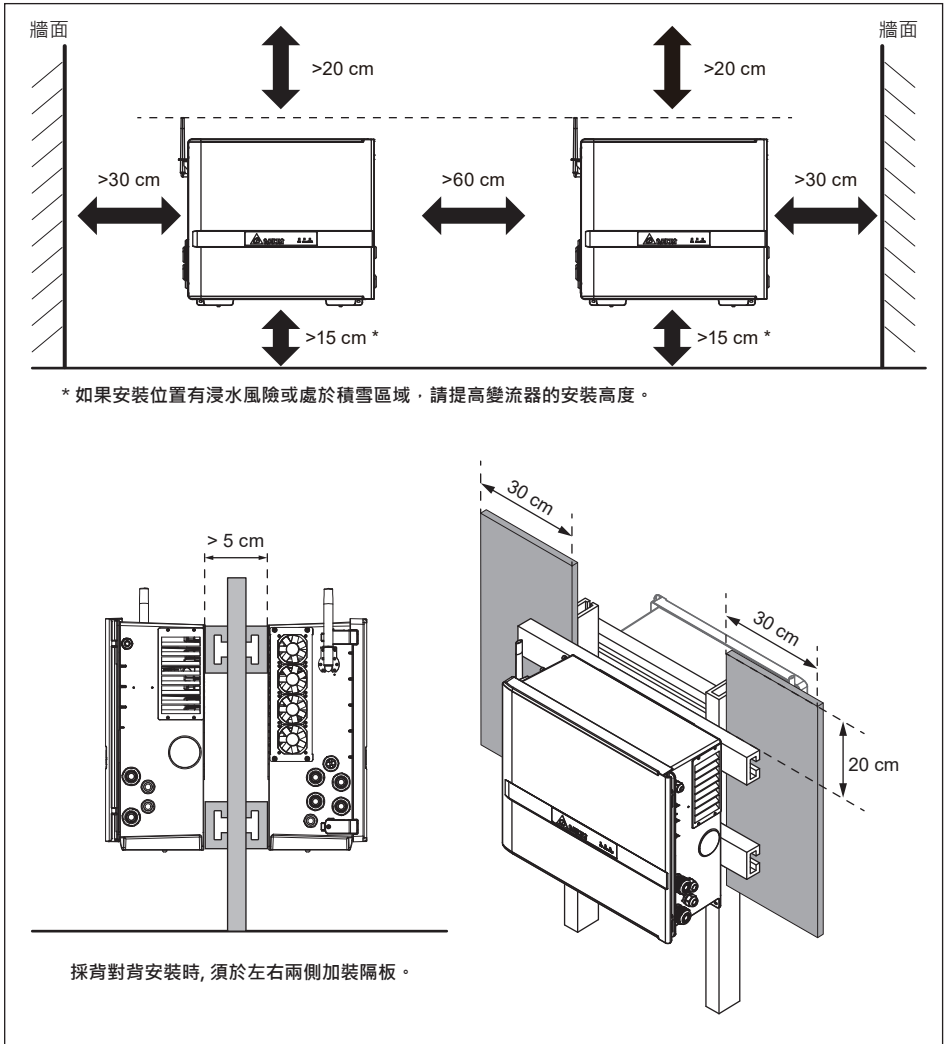

- 請確保安裝基座足以承載變流器重量。

落地支架為選配套件，請聯繫客服中心取得詳細資訊。

1. 將落地支架安裝於變流器腳座上，如圖3-9所示
2. 以4顆膨脹螺絲安裝落地支架於地面基座上，如圖3-10所示



圖 3-9: 落地支架安裝



圖 3-10: 將變流器安裝在地面安裝基座上

3.3 佈線

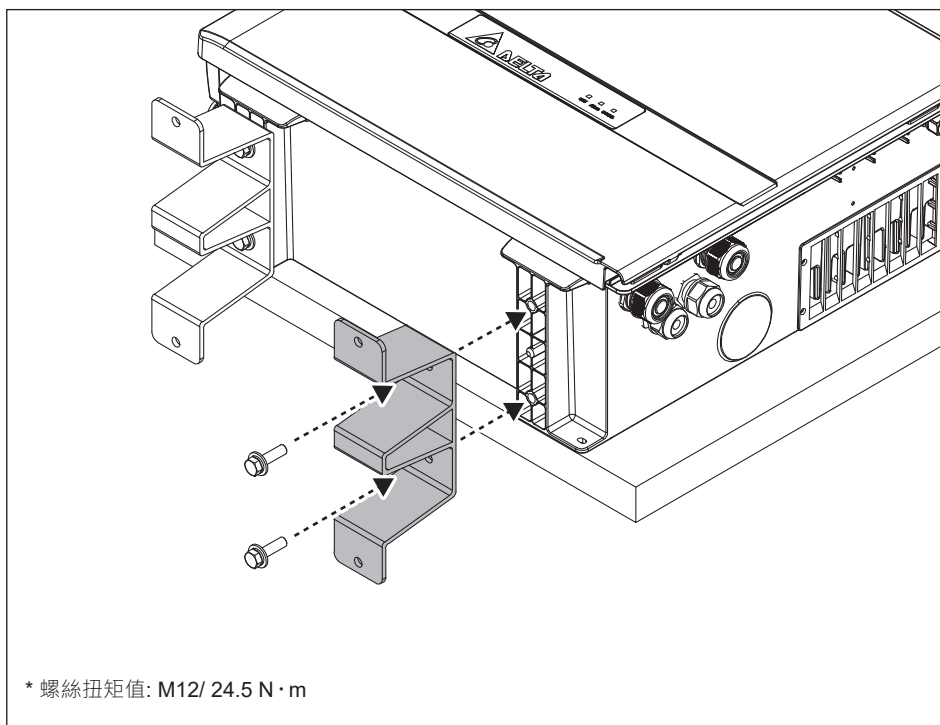
請依循以下原則進行佈線，以避免雨水流入電纜密封套，可確保變流器長時間運行之防水能力。

1. 距電纜密封套 10-20 cm 之電纜應維持水平佈線
2. 以固定座或導線槽固定與支撐導線使其與變流器之間水平無歪斜
3. 固定前之導線以下凹形式產生雨水截流

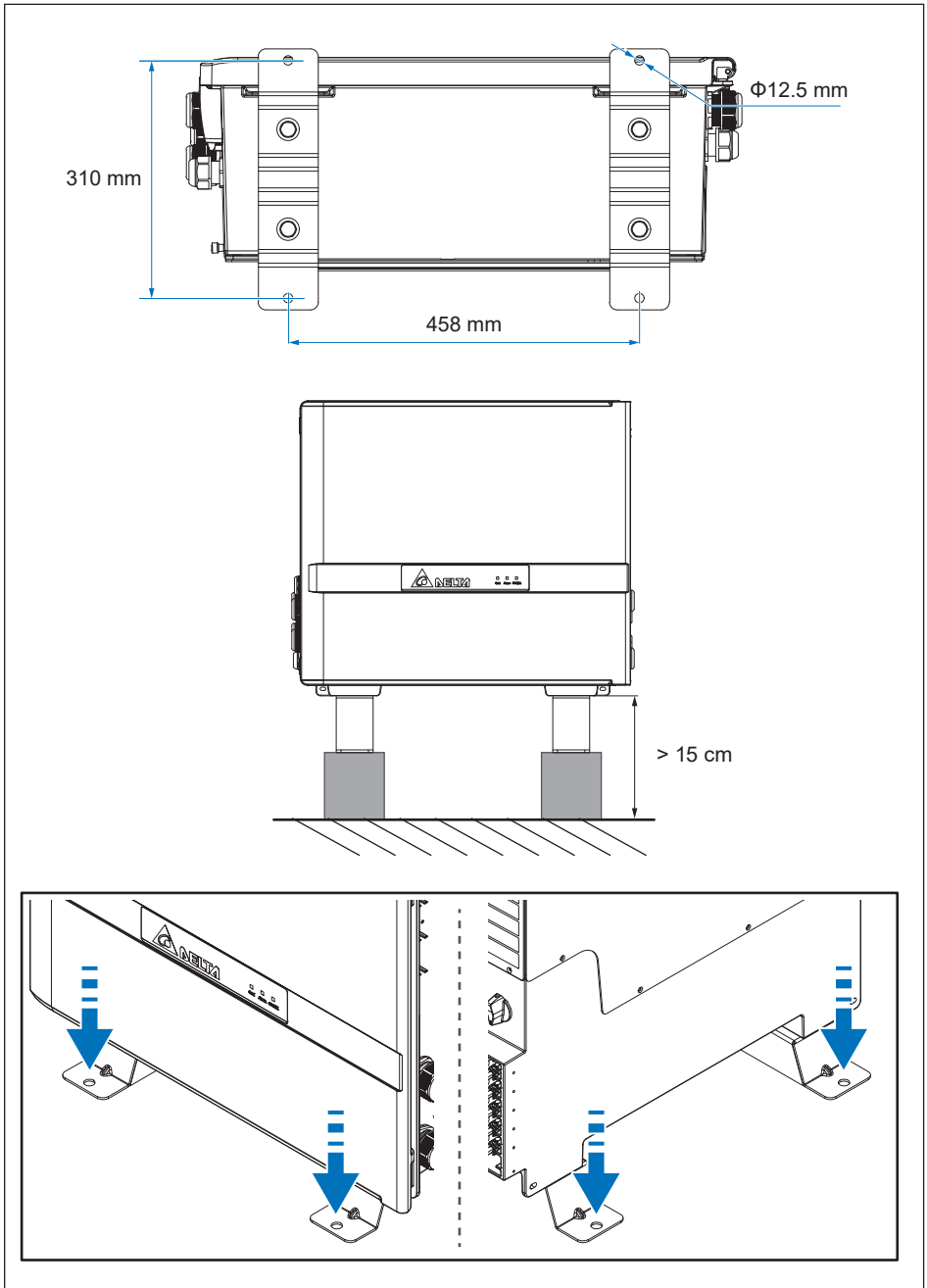

圖 3-11: 佈線

為了預防渦流效應的產生，請勿將三相交流電纜分置於獨立的金屬管，請參考以下建議安裝方式配置。

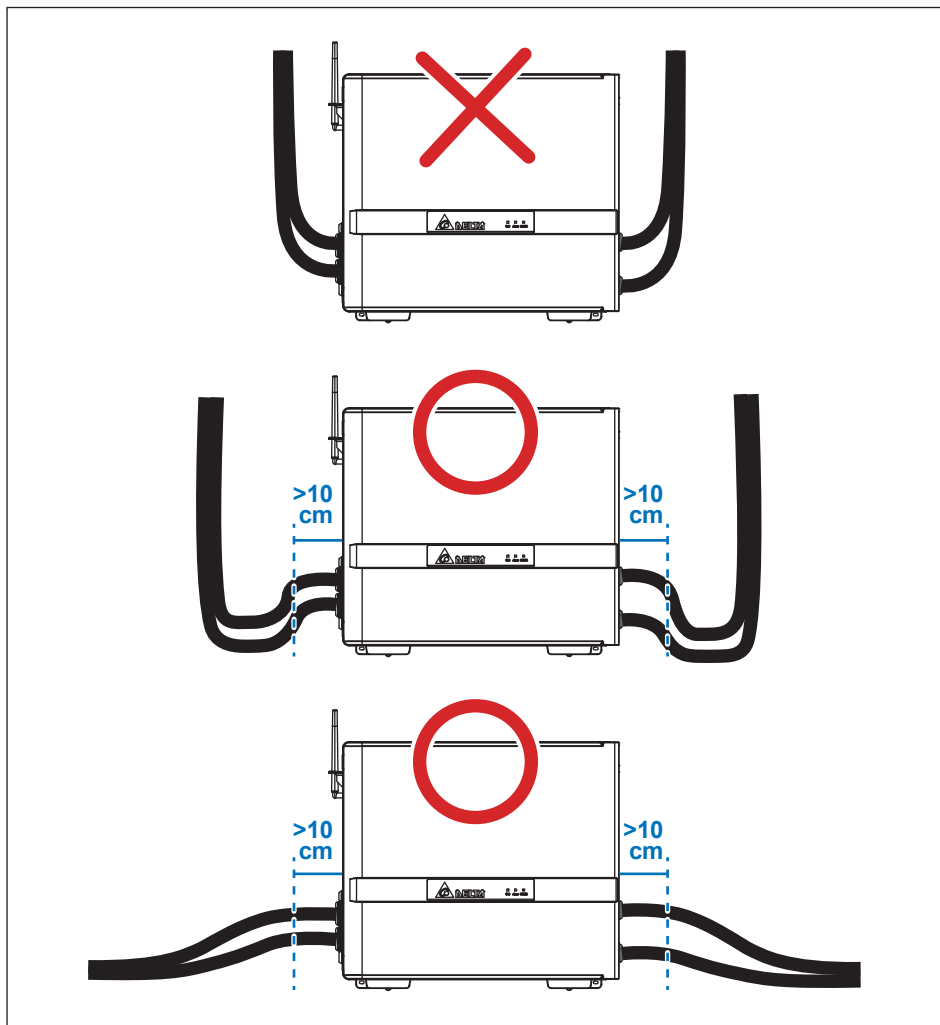

圖 3-12: 交流側金屬管安裝配置

注意！



- 防水塞蓋裝配線後不能產生縫隙避免水、灰塵或生物入侵。
- 防水塞蓋應確實鎖緊，不能產生鬆動。

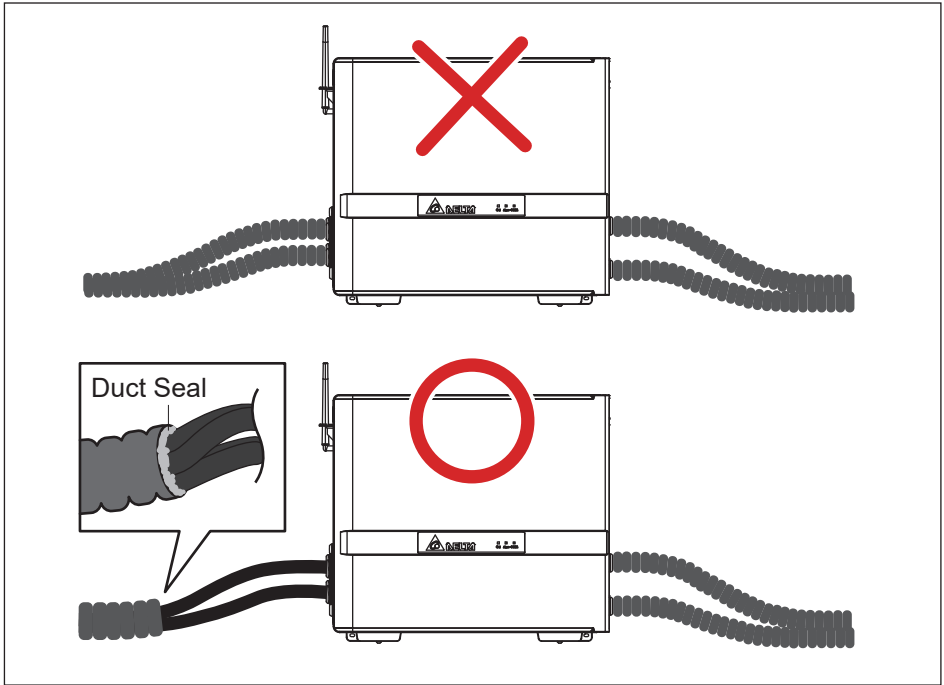
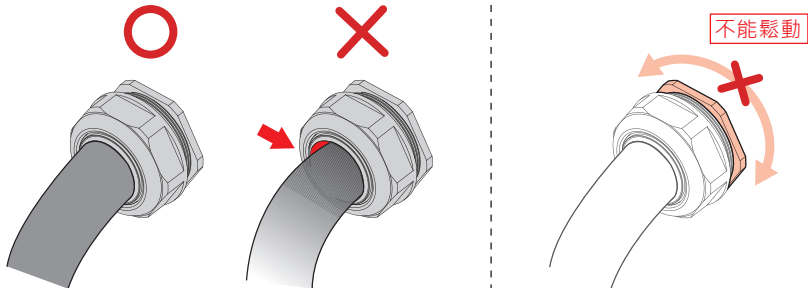

3.4 交流配線安裝

危險：觸電危險!!



- 配線時禁止供給變流器任何電源，以避免觸電。

警告！



- 遵守條文為安裝者的責任。
- 直流電壓超過1000V則保固失效。

注意：變流器及設備可能損毀！



- AC端子安裝須遵守當地電氣法規。
- 不遵守指示可能會損壞交流線材。

注意：錯誤的交流線材！



- 為了不損壞變流器中的組件，請確保將正確的線材連接到變流器上相應的交流端子。

開啟或關閉前蓋時，請務必遵循5.1章節步驟。

3.4.1 AC 形式與連接方式

注意



機器初始設定為 3Ø-3W 接線方式，也可變更為 3Ø-4W 含中性點N的接線方式。變流器可工作於下述電力系統連接方式無須額外配接外部變壓器。

TN-C

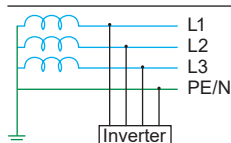

TN-C-S

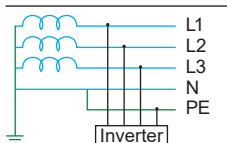

TN-S

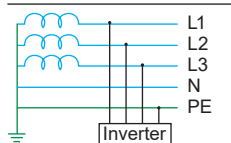

TT

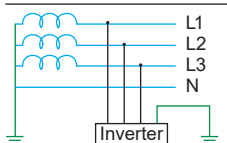

IT *

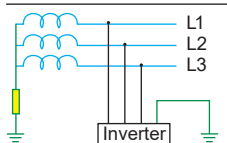

* 確保IT系統中從L1、L2、L3與PE（保護地）間之跨壓必需低於±600V之範圍內。

3.4.2 必要保護裝置

建議於交流端安裝過電流保護裝置，安裝三相交流斷路器可以保護變流器的交流線路，並且可以安全地進行系統維護。M100_210交流斷路器最低要求如下表。

表 3-1：交流斷路器之建議規格

額定電流	min. 200A
額定電壓	min. 380V / 400V
極數	3 / 4

3.4.3 交流線材準備

- 請使用銅或鋁材質之導線
- 導線截面積範圍: 70mm² - 185mm²
- 線材總直徑範圍: 12.0mm - 28.9mm
- 可使用絞線和實心線。當使用平波花線時，則需壓接端子。

注意



- 基於防水與防塵效果之考量，不建議使用多芯電纜進行配線。

3.4.4 接地線材準備

變流器必須通過內部或外部接地點接地，接地線材應符合以下要求。

- 導體的橫截面必須為交流線材橫截面的 $\frac{1}{2}$ 以上
- 請遵循下表使用正確之端子進行連接

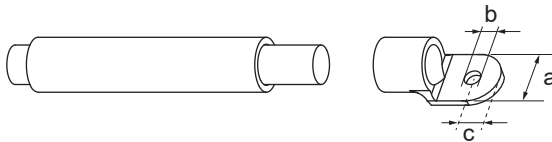

	內部接地	外部接地
最大導體截面積	120mm ²	120mm ²
線材外徑範圍	9.5 - 18.8mm	-
線材端子尺寸	螺絲尺寸 = M8 a < 24.0mm b = 10.5mm c < 12.5mm	螺絲尺寸 = M8 a < 24.0mm b = 10.5mm c < 12.5mm

3.4.5 接地線安裝

注意！



- 變流器之接地可以保護人員避免受到電擊，建議優先進行接地線之安裝。

M100_210 有一個內部接地端子和兩個外部接地點。接地線可以安裝在內部、外部或兩者上，並且電纜的尺寸應正確使用，請參閱3.4.4。



圖 3-13：內部接地端配線

內部接地端子

(1) 使用適當內部橡膠將接地保護電纜穿過M25電纜密封套並插入內部接地端子。

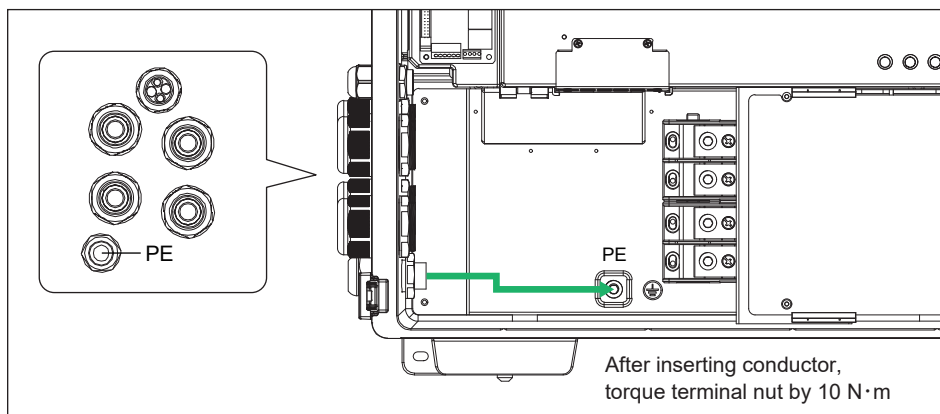
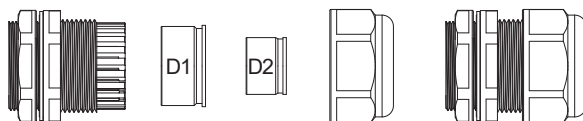

	Cable diameter range	Torque	Dimension of P
D1	14.1-18.8 mm	3.5-5.2 N·m	1.5-5.0 mm
D2	9.5-14.1 mm	3.5 N·m	1.5-5.0 mm

(2) 使用M8扳手以10 N·m的扭矩鎖緊螺母。

(3) 鎖緊用於保護的接地電纜密封套。

外部接地點

將接地線壓接O型端子後，以M8螺絲鎖附於機殼外部接地點，機殼外部接地點位置如圖3-14所示。



圖 3-14 : 設備接地點

3.4.6 交流配線

危險:觸電危險!!

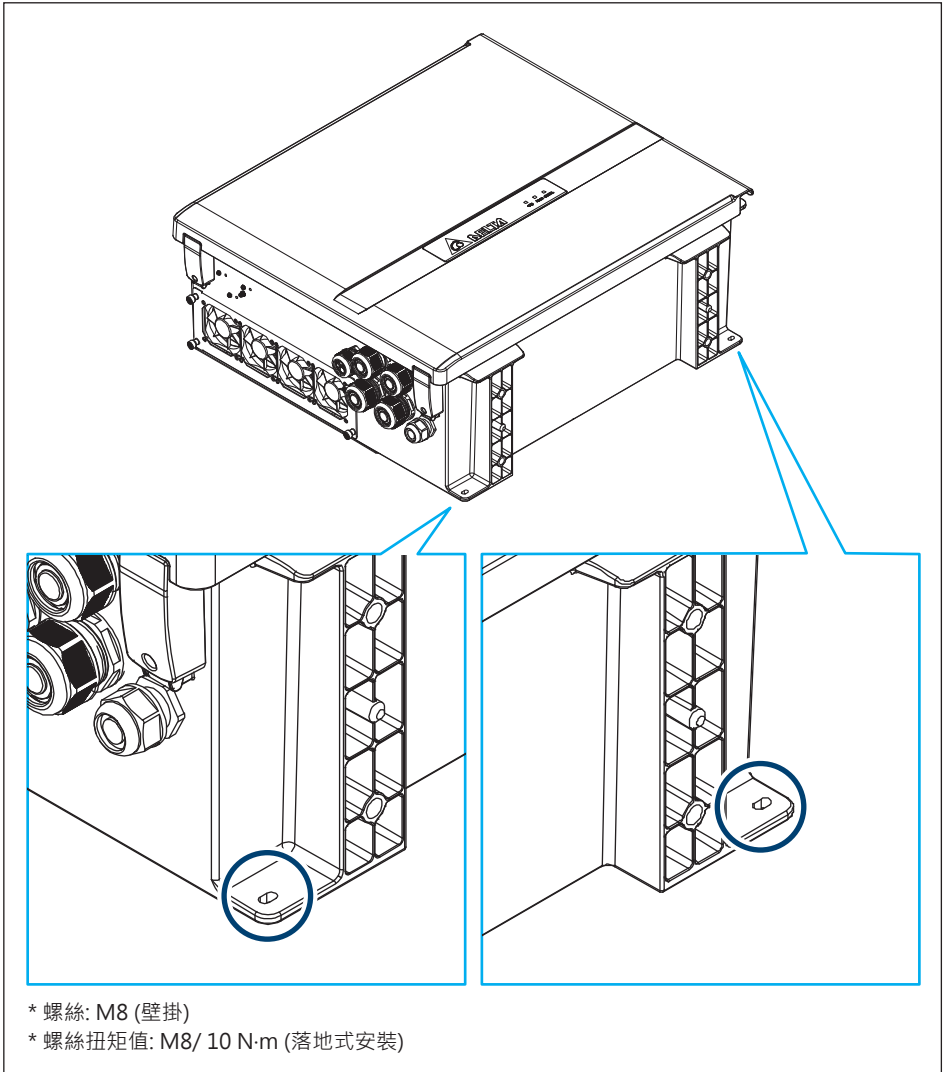

- 確保交流電源線於安裝過程中沒有電力來源，以避免觸電危險。



圖 3-15 : 交流端配線

- (1) 確保交流斷路器處於“關閉”狀態。
- (2) 剝去電纜絕緣皮30mm。
- (3) 對於鋁質導線，請去除導體表面的氧化膜並塗上防護油脂。
- (4) 使用適當的內部橡膠將L1·L2·L3或中性線(若需配置)穿過對應的M40電纜密封套。
- (5) 按照標示連接L1·L2·L3和中性線(若需配置)。
- (6) 以31 N·m的扭矩鎖緊所有端子與螺絲。
- (7) 擰緊所有交流電纜密封套以確保密封。

注意！

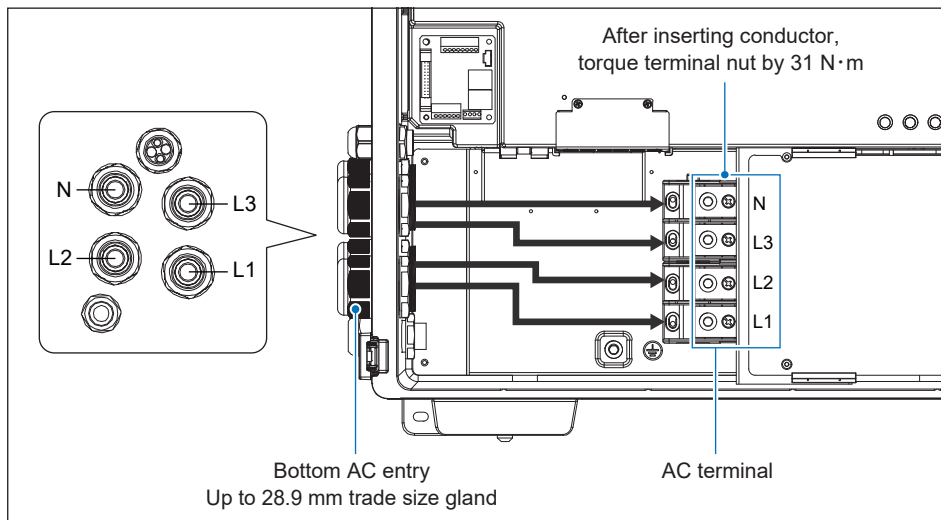

- 配線完成後請確認電纜密封套進線孔的地方是否有間隙，若有，請使用矽利康或防火泥進行填塞
- 若採用塑膠或HDPE材質等管路進線，管內請確實使用矽利康或防火泥進行填塞進行填塞

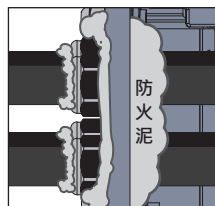

3.5 直流配線安裝

危險:觸電危險!!



- 來自太陽能匯流箱直流電纜上之高能量可能會導致觸電危險。確保直流電纜處於斷電狀態，直到完成直流配線安裝為止。

警告!



- 觸電及火災危險。僅允許使用有標示低於1100V的太陽能串列。

注意



- M100_210會在每天首次操作之前進行直流線路之絕緣電阻檢查，但直流感地故障仍可能在運行期間損壞變流器，並且不在保固範圍內。
- 確保直流電纜沒有接地故障。

開啟或關閉前蓋時，請務必遵循5.1章節步驟。

3.5.1 直流線材準備

- 僅接受銅或鋁材質之導線
- 可用絞線和實心線
- 必須壓接R型端子
- 鋁導體必須使用銅鋁合金端子，以防止電化學腐蝕

M100_210可支援一個或兩個PV匯流箱輸入。兩種情況下直流電纜之要求不同。

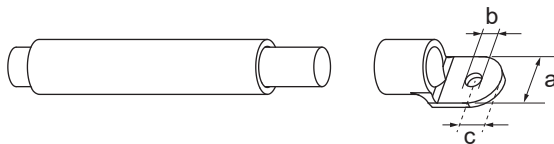

Case of DC input	1 PV combiner box	2 PV combiner boxes
Max. conductor cross section	185mm ²	120mm ²
Cable diameter range	12.0 – 28.9mm	9.5 - 18.8mm
Cable lug dimension	Size of bolt = M10 a < 40.0mm b = 10.5mm c < 16.0mm	Size of bolt = M10 a < 40.0mm b = 10.5mm c < 16.0mm

3.5.2 直流電纜安裝

警告!



- 安裝直流電纜前，請確保太陽能匯流箱中之所有直流隔離開關均已關閉且鎖定，以確保安全。
- 接觸直流導體之前，請透過電錶確認直流電纜之兩極是否沒有電壓。



圖 3-16: 多層式防水塞蓋

表 3-2: 電纜線尺寸對照表

M40	Cable diameter range	Torque	Dimension of P
D1	21.7-28.9 mm	5.5-10 N·m	1.0-8.0 mm
D2	16.2-21.7 mm	6.0 N·m	1.0-6.5 mm
D3	12.0-16.2 mm	4.0-6.5 N·m	1.0-7.5 mm

M25	Cable diameter range	Torque	Dimension of P
D1	14.1-18.8 mm	3.5-5.2 N·m	1.5-5.0 mm
D2	9.5-14.1 mm	3.5 N·m	1.5-5.0 mm

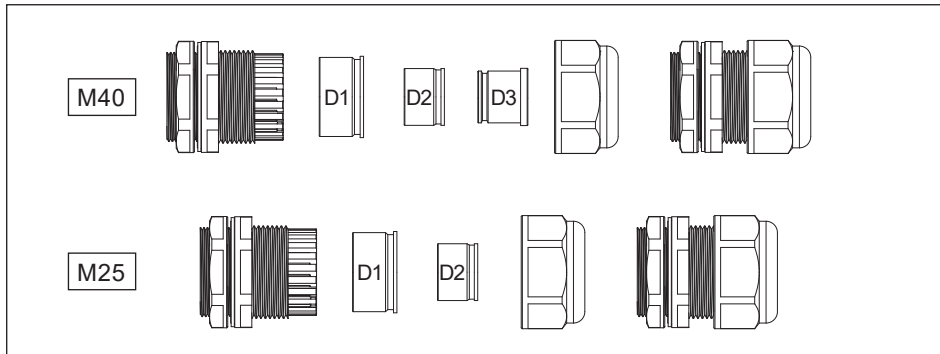

圖 3-17: 滑動保護蓋

警告！

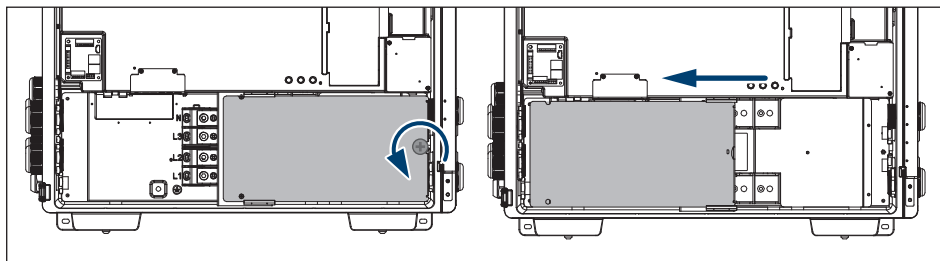

- 禁止極性反接，將造成產品損壞。
- 變流器容許最大電壓極限為1100V。

單太陽能匯流箱輸入



圖 3-18: DC端配線 (單太陽能匯流箱)

- (1) 使用適當之內部橡膠將PV+或PV-電纜穿過各個M40電纜密封套
- (2) 按照圖3-18所示配置PV+或PV-電纜至各個端子上
- (3) 使用M10扳手以16 N·m之扭矩擰緊螺母
- (4) 擰緊所有M40電纜密封套以確保密封

注意！

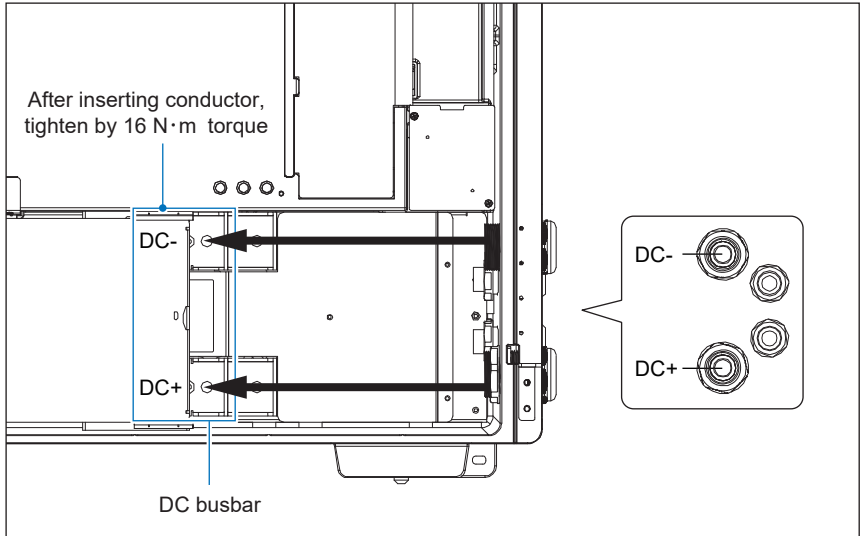

- 配線完成後請確認電纜密封套進線孔的地方是否有間隙，若有，請使用矽利康或防火泥進行填塞
- 若採用塑膠或HDPE材質等管路進線，管內請確實使用矽利康或防火泥進行填塞進行填塞

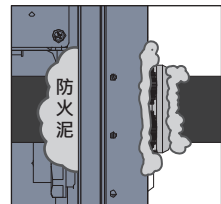

警告!



- 禁止極性反接，將造成產品損壞。
- 變流器容許最大電壓極限為1100V。

雙太陽能匯流箱輸入



圖 3-19: DC端配線 (雙太陽能匯流箱)

- (1) 將兩組PV電纜(共4條DC電纜)分別穿過M40和M25電纜密封套，每個電纜密封套之內部橡膠必須適合電纜的外徑。
- (2) 按照圖3-19所示配置PV +或 PV-電纜至各個端子上
- (3) 使用M10扳手以16 N-m之扭矩擰緊螺母
- (4) 擰緊所有M40與M25電纜密封套以確保密封

注意!

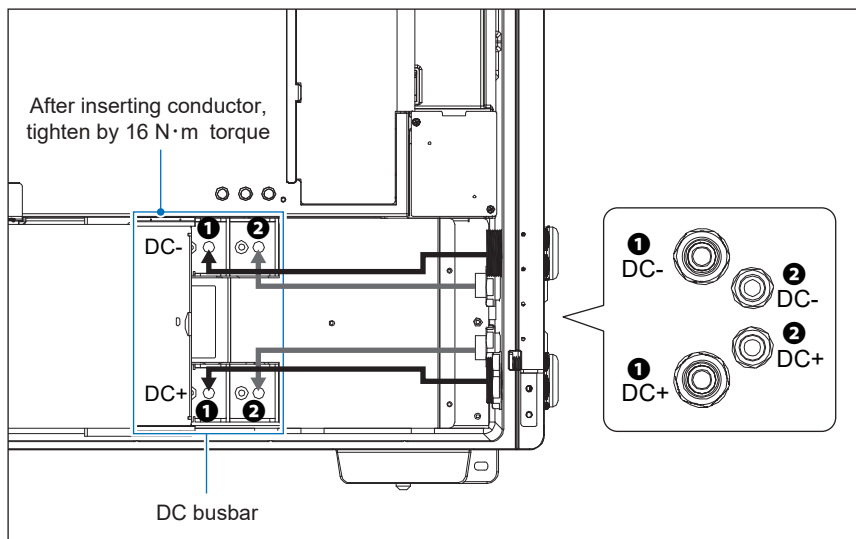

- 配線完成後請確認電纜密封套進線孔的地方是否有間隙，若有，請使用矽利康或防火泥進行填塞
- 若採用塑膠或HDPE材質等管路進線，管內請確實使用矽利康或防火泥進行填塞進行填塞

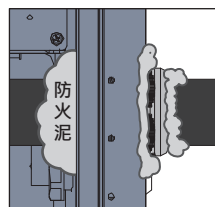

3.6 SUB_1G 天線 (選配)

本機器支援SUB_1G無線通訊，請依照圖3-20至圖3-22步驟安裝專用天線。

注意



- 不使用天線時，請確實鎖上防水螺母外蓋及天線支架的三顆螺絲。

➔
安裝位置

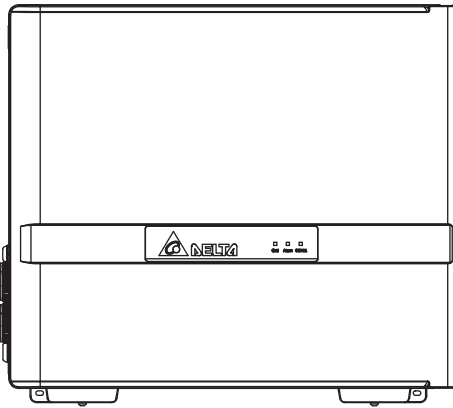

卸下防水螺母外蓋。

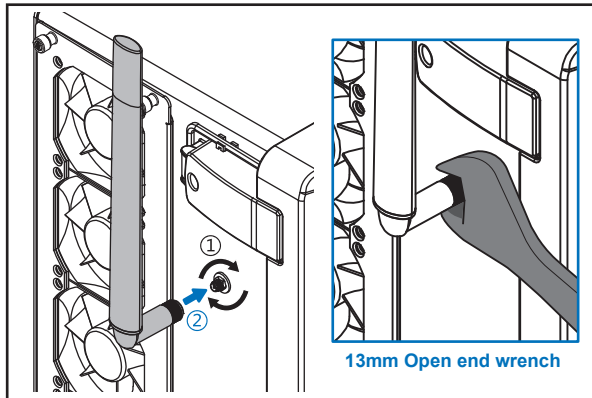

請使用1.2N·m的扭力安裝天線。

圖 3-20：天線安裝



圖 3-21：安裝天線的注意事項

1. 卸除機身上的三顆螺絲並逆時針旋轉天線約45度。
2. 裝上天線支架。
3. 將天線轉回適當位置(天線保持向上)。
4. 將天線配件包中的三顆M4螺絲以圖3-20之位置及扭矩值鎖緊。

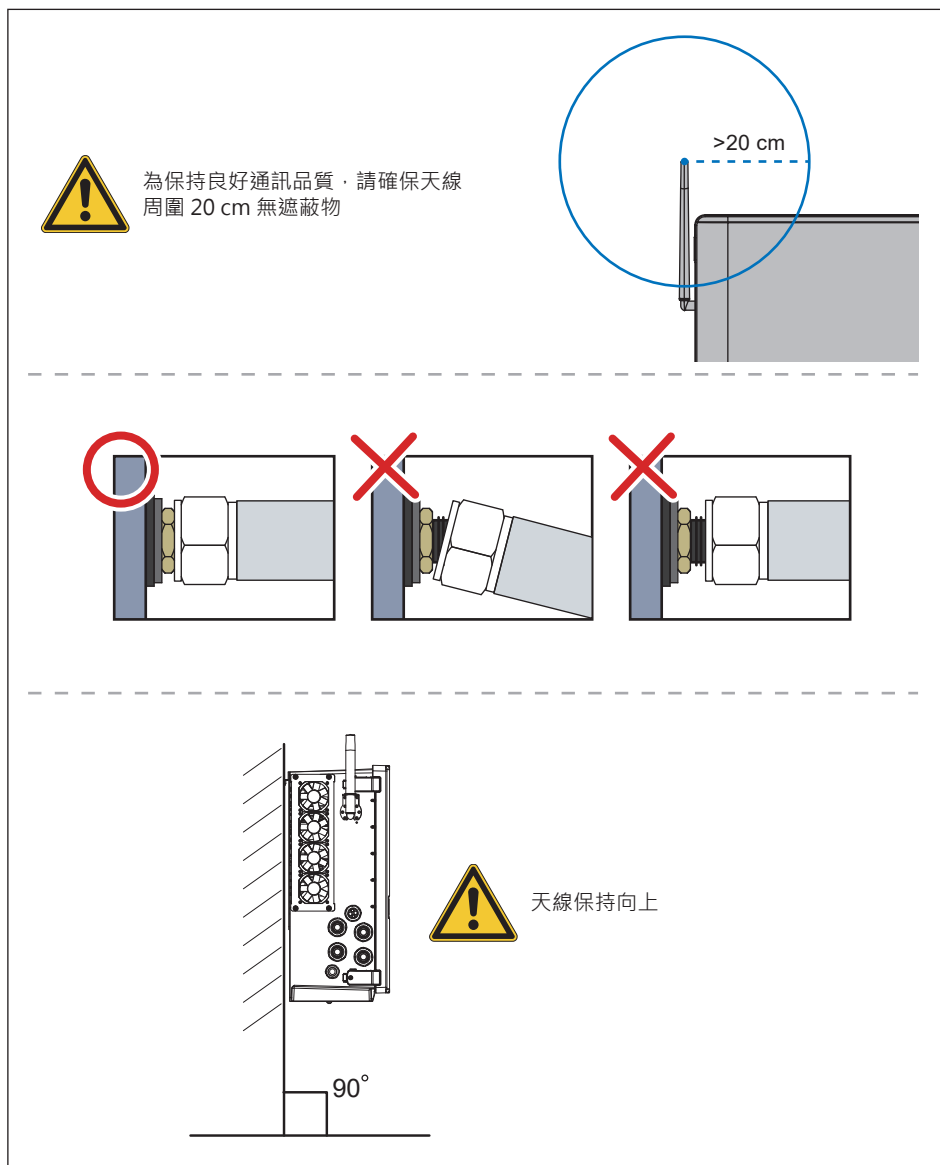

圖 3-22 : 安裝天線支架

注意



- 當配合DELTA PPM DC1_100使用時，請參閱PPM DC1_100使用說明書
https://mydeltasolar.deltaww.com/?p=product_manual

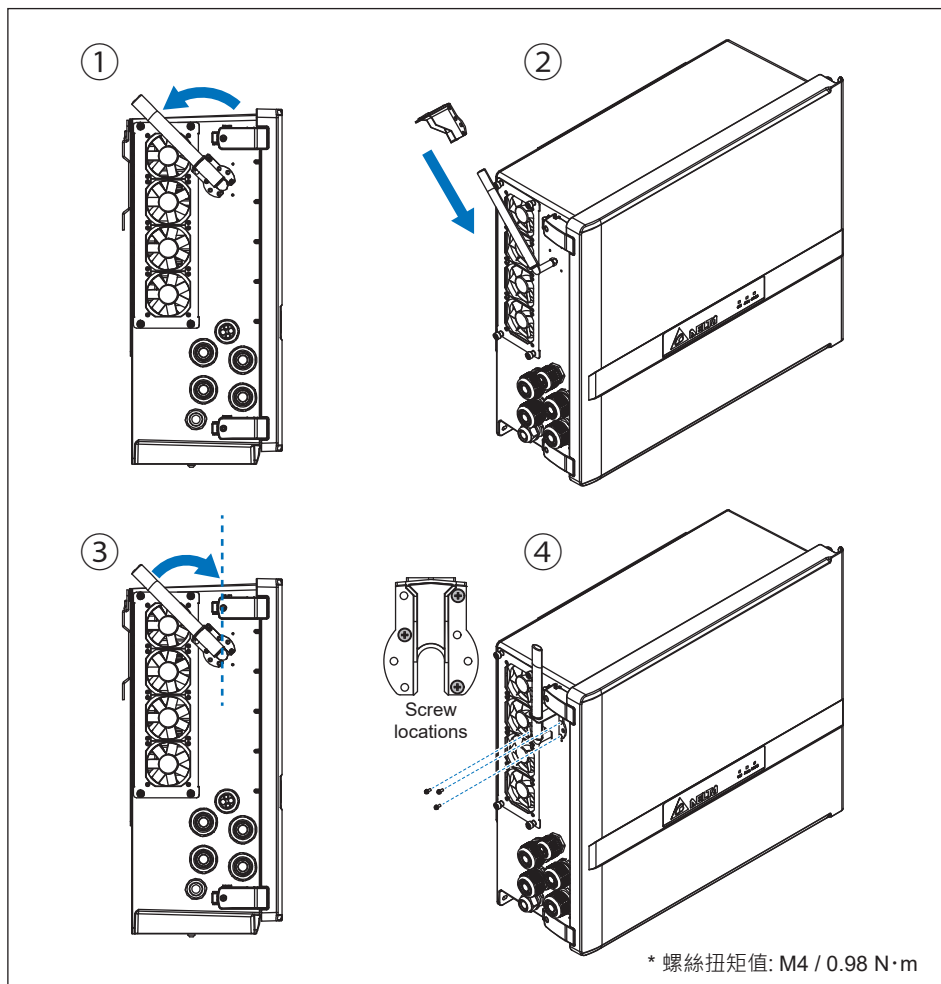

3.7 通信模組

通信模組如圖3-23所示。

該模組提供一組12V電壓源VCC、RS-485、乾接點、EPO和數位輸入端子供功率控制使用；詳細說明如下。

使用VCC 與GND輸出腳位，可提供一12VDC電源，可供外部裝置使用。



圖 3-23 : 通信模組



圖3-24：通信模組位置圖

3.7.1 RS-485 連線

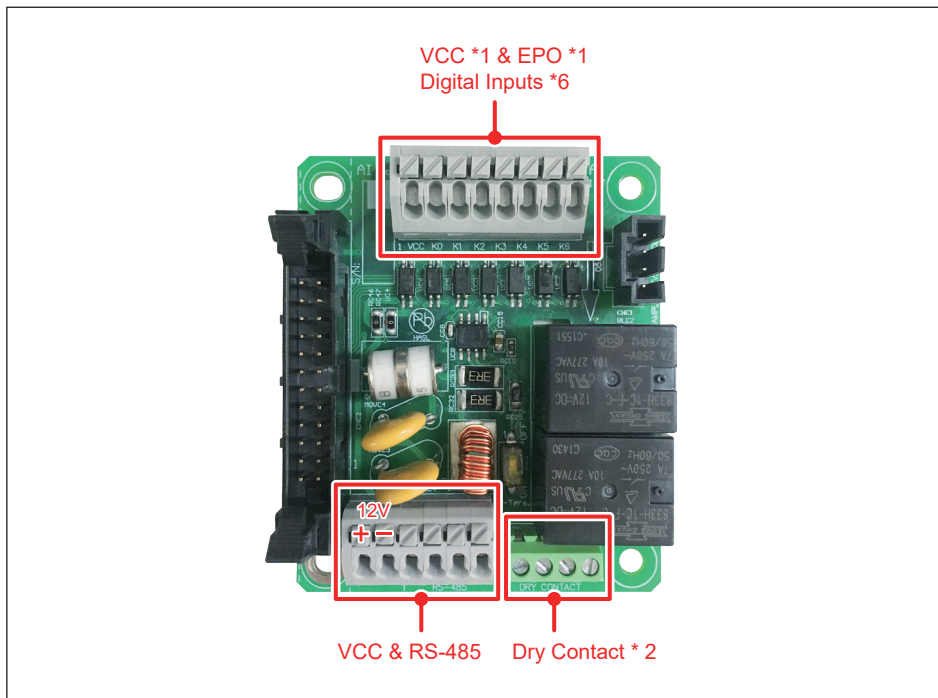
RS-485端子座腳位定義如表3-3所示

- 腳位1與2提供直流電壓12V/0.5A電源
- 腳位3與5 為RS-485差動信號之DATA+ 信號專用腳位
- 腳位4與6 為RS-485差動信號之DATA- 信號專用腳位

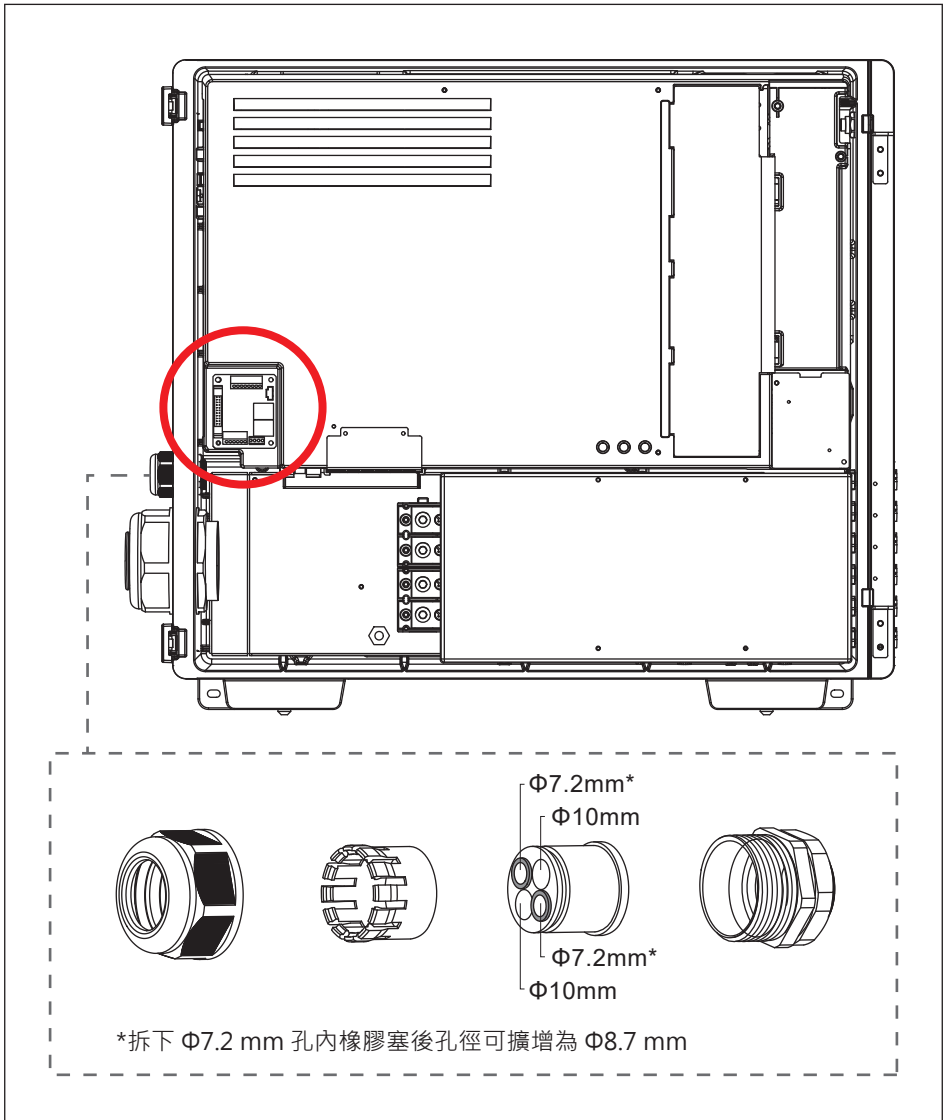
依據上述的腳位，可以實現多台變流器的通信連接。

本機器設有120歐姆終端電阻，可使用通信模組上的控制開關進行切換(表3-3)。不同的RS-485連接方式時，需使用不同的終端電阻設定方式。

- 當多台變流器連接時，只有最後一台變流器必須將終端電阻接通如圖3-25。
- 如果RS-485總線長度大於610m，建議使用Belden 3105A電纜或同規品來確保通信品質。

注意



- 為確保良好的通信品質，建議使用絞線之電纜方式配置。

表 3-3: RS-485 端子座說明

Pin	Function
1	VCC (+12V)
2	GND (非系統接地)
3	DATA+
4	DATA-
5	DATA+
6	DATA-

資訊



當RS-485需要接地時，請遵循以下步驟

1. 從隔離層剝出一條接地線(線徑: 0.5~1.5 mm²)，並做適當絕緣防護
2. 將接地線壓接Y端子(建議型號: SNYBL1-4)，並鎖附於下圖A處

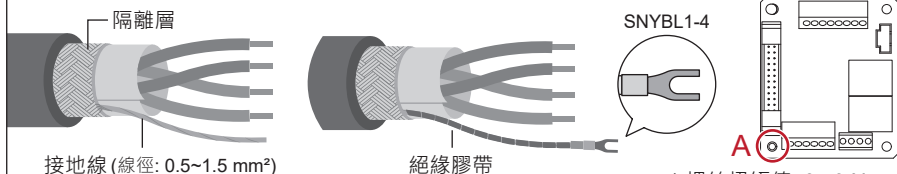

* 螺絲扭矩值: 0.59 N·m



圖 3-25：多台併接通訊示意圖



表 3-4：終端電阻設定說明

	Switch 1
ON	Terminal Resistor ON
OFF	Terminal Resistor OFF

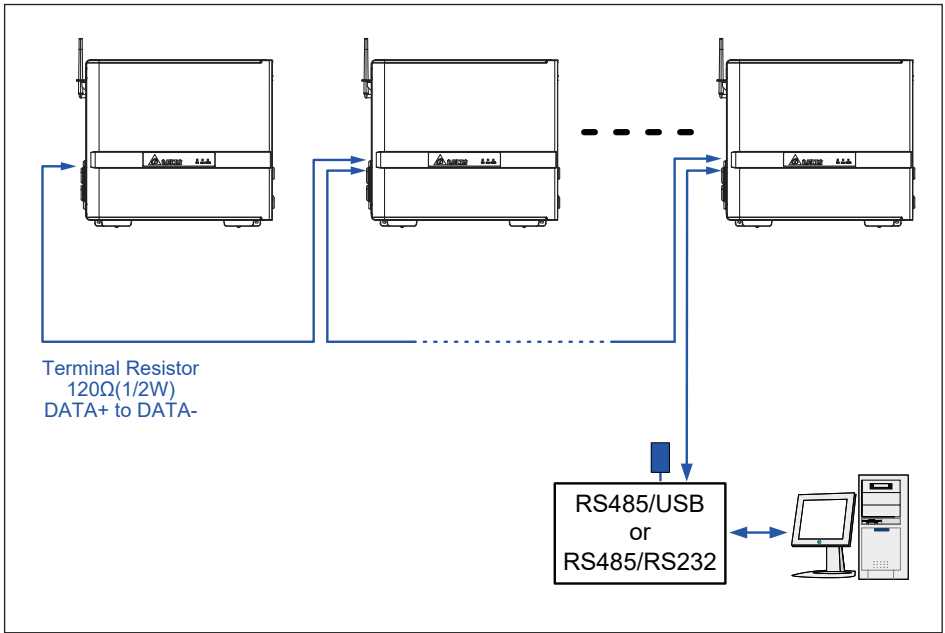
3.7.2 EPO 緊急關斷功能與數位輸入

本通信模組提供緊急關斷功能(EPO)。
 可使用APP 或Delta Solar System (DSS)進行設定。

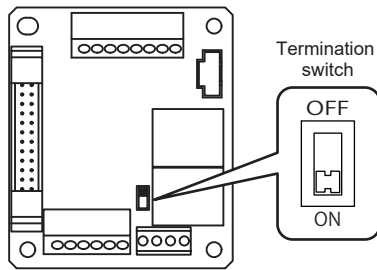

圖 3-26 : 緊急關斷功能端子座

利用VCC和K0連接，可啟用EPO功能。此外，還可以利用數位輸入功能，進行功率降低控制，限制變頻器的有效輸出功率。此控制設置可依據表3-5 所示的方式，將對應的兩個腳位進行短路來實現。

表 3-5: 數位輸入與EPO功能說明

短路腳位	變流器動作反應
VCC & K0	緊急關斷 (EPO)
VCC & K1	控制至0 % 額定功率
VCC & K2	控制至30 % 額定功率
VCC & K3	控制至60 % 額定功率
VCC & K4	控制至100 % 額定功率
VCC & K5	預留
VCC & K6	預留

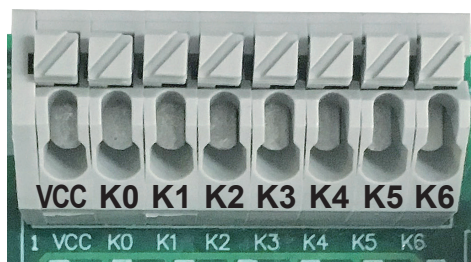
3.7.3 乾接點連接說明

M100_210提供兩組乾接點端子，可依據變流器運行狀態控制外部裝置。該功能的接線端子如圖3-27所示，圖中標示為兩組乾接點端子位置，乾接點為常開狀態，其動作方式定義，使用者可藉由DSS進行設定。



圖 3-27：乾接點連接位置圖

4 試運行

注意：表面高溫，請勿觸碰！

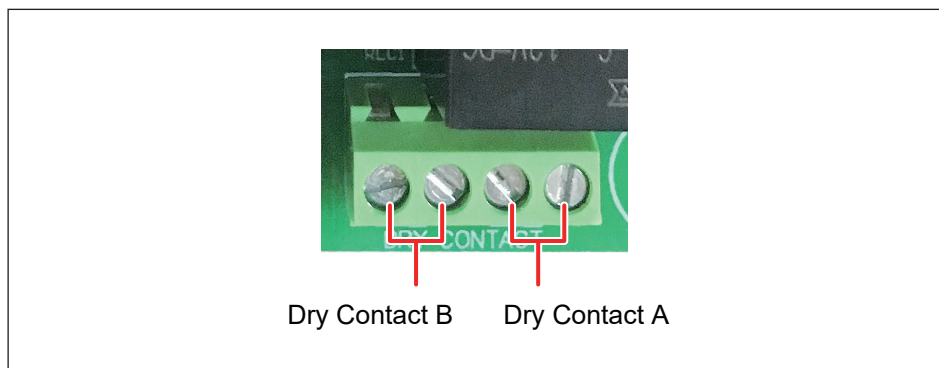

- 當開蓋時請小心表面高溫。
- 表面冷卻前請勿接觸變流器。

4.1 控制面板介紹

M100_210 提供3顆LED 燈號提供變流器的狀態顯示，如圖4-1所示。

LED燈狀態對應表，請參考表 4-1 所示，可利用該表獲得變流器運行狀態資訊。



圖 4-1：顯示面板

表 4-1: LED 指示燈

狀況	Grid (綠)	Alarm (紅/黃)
Countdown	FLASH	OFF / OFF
On Grid	ON	OFF / OFF
Inverter Fault / Remote off	OFF	ON / OFF
Inverter Warning	ON (or OFF)	FLASH / OFF
Field Fault	OFF	OFF / ON
Field Warning	ON	OFF / FLASH
NO DC	OFF	OFF / FLASH SLOW
FW Upgrade	FLASH	FLASH / OFF
Standby	FLASH	OFF / FLASH
Check PV Power	FLASH FAST	OFF / FLASH FAST
System Lock	OFF	FLASH / FLASH

*FLASH: ON 1s / OFF 1s

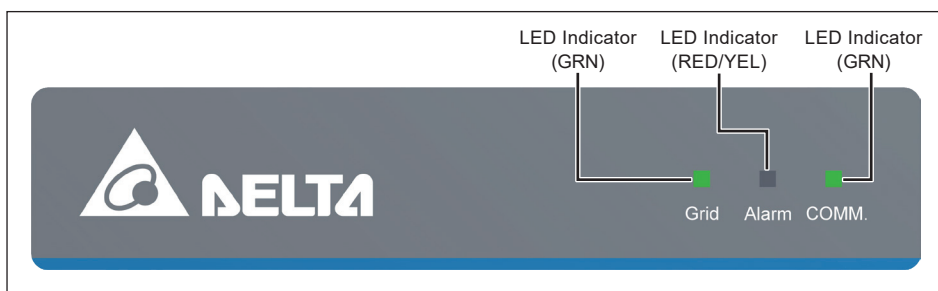
FLASH FAST: ON 0.25s / OFF 0.25s

FLASH SLOW: ON 5s / OFF 10s

表 4-2: 無線通訊指示燈

通訊狀態	COMM. (綠)
Wi-Fi and Sub_1G	FLASH (ON 1s / OFF 1s)
Wi-Fi	FLASH (ON 1s / OFF 2s)
Sub_1G	FLASH (ON 3s / OFF 2s)
Offline	OFF

4.2 自動ID設定

透過以下兩種軟體可以使用自動ID設定功能，一次設定所有變流器ID

- DSS (Delta Solar System)

變流器可透過RS485接線或是Wi-Fi連接至電腦，使用DSS進行設定。

- DeltaSolar APP

變流器透過Wi-Fi連接行動裝置(智慧型手機、平板等)，使用APP進行設定。

4.2.1 DSS連接

- ① 選取欲設定的機種
- ② 點擊 “RS485 ”
- ③ 選取通訊端 (程式自動偵測)
- ④ 點擊 





圖 4-3 : DSS連接

4.2.2 掃描變流器

- ① 點擊 “Auto ID 

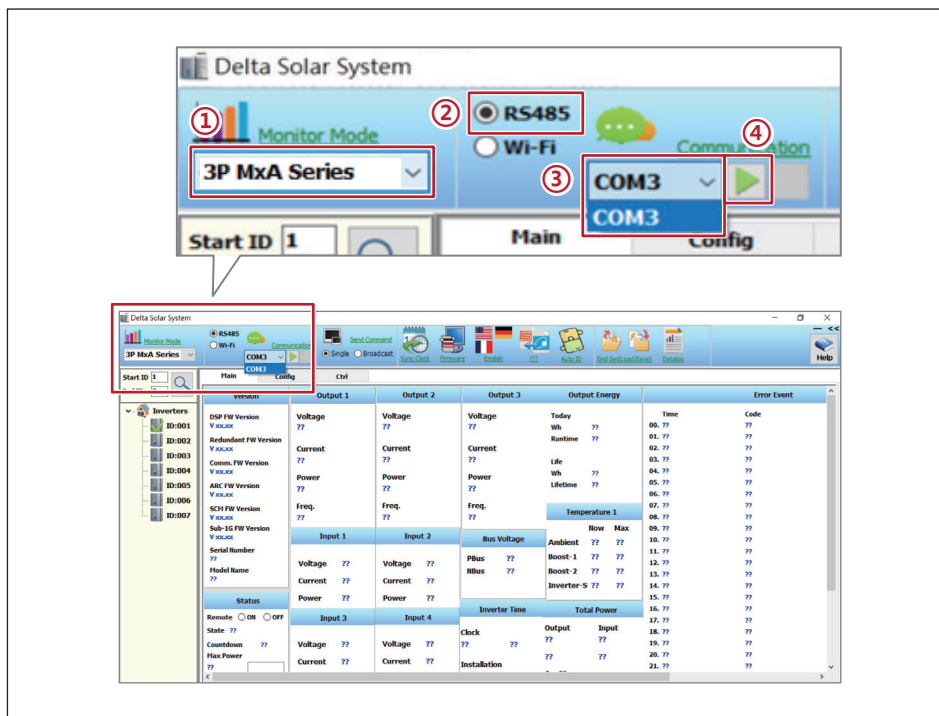
The image displays the Delta Solar System software interface in three stages of the inverter scanning process:

 - Top Screenshot:** The main dashboard with the 'Auto ID' button highlighted by a red circle and a red box. The interface shows various system parameters and a table of inverter data.
 - Middle Screenshot:** The 'Auto ID' dialog box is open. The 'Inv Num' field is empty, and the 'Scan Inverters' button is highlighted with a red circle and a red box. The status is 'Completed - Set Country'.
 - Bottom Screenshot:** Two sequential views of the 'Auto ID' dialog box. In the first, 'Inv Num' is set to '1' and the status is 'Scanning'. A red arrow points to the second view, where the status is 'Next Step - Set Inverter ID'.

圖 4-3 : 變流器掃描

4.2.3 ID設定

- ① 被掃描到的裝置將顯示序號及系統預設ID，可以手動變更ID
- ② ID設定完成後點擊“Set ID”



圖 4-4 : ID設定

4.2.4 國別設定

- ① 選取變流器國別
- ② 點擊 “Set Country”

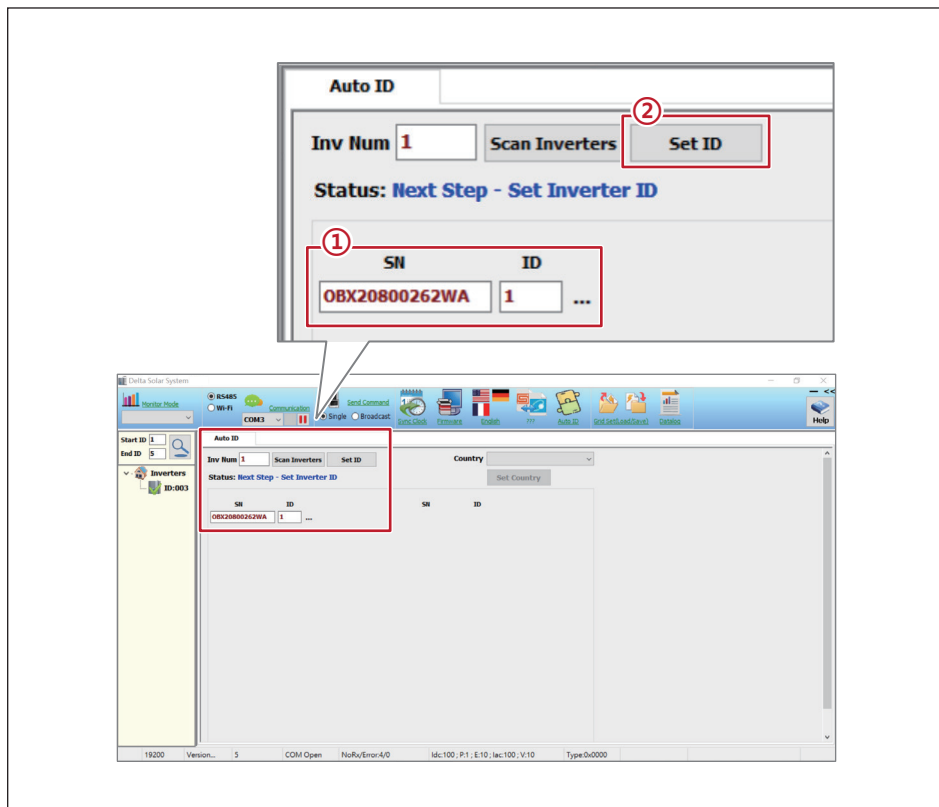

圖 4-5：國別設定

4.2.5 時間同步設定

點擊 “Sync Clock  ” 以同步時間設定

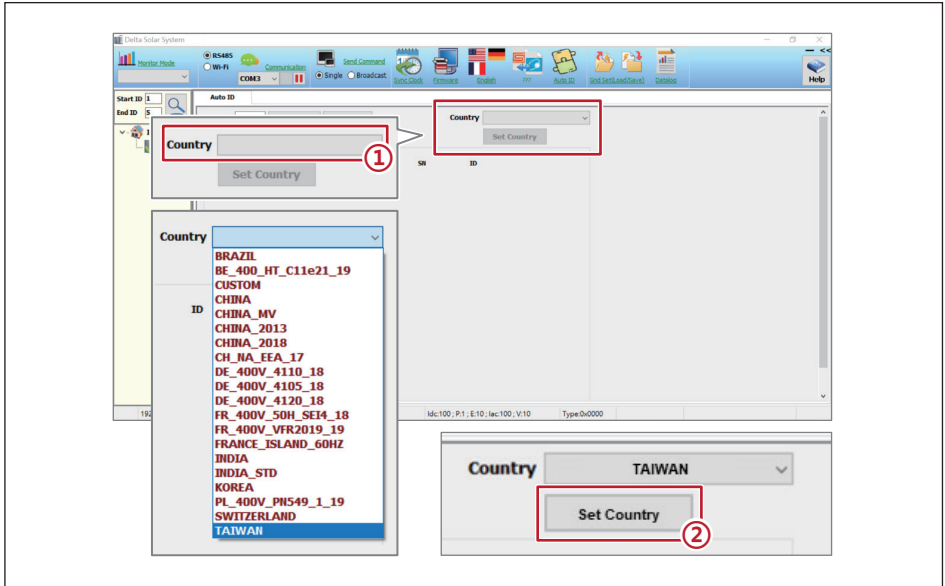

圖 4-6 : 時間同步設定

4.3 Delta功能設定

Delta 提供兩種機器設定方式：

DSS (Delta Solar System Software) 與 APP(MyDeltasolar)

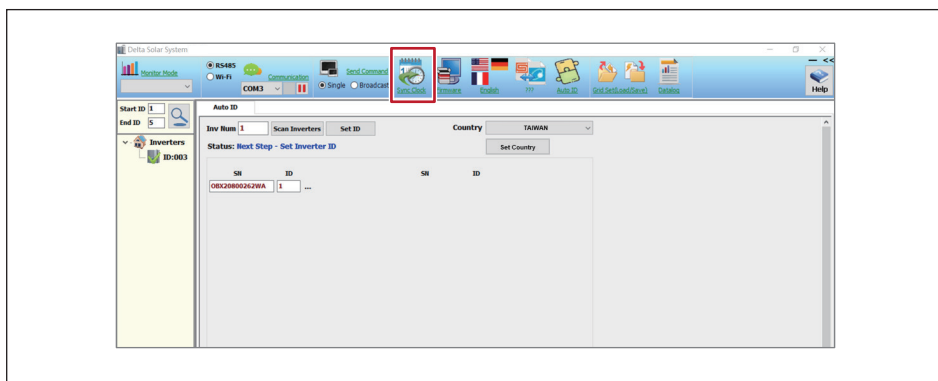
功能列表	
Active power control	Q(U) control (volt-var control)
P-F control (watt-frequecy control)	Q by night(Q setting 24/7)
P(U) control (volt-watt control)	Anti-PID
Fixed cosφ	Dry contact
Fixed Q(%)	ARC fault detection
Auto ID	Wi-Fi

請掃描下方連結取得使用說明



DSS 操作手冊:

https://mydeltasolar.deltaww.com/manual/eng/SUB_1G/DSS.pdf



APP (DeltaSolar) 操作手冊:

<https://mydeltasolar.deltaww.com/index.php?p=manual>

5 維護

為確保變流器正常運轉並保持良好狀態，建議至少每年進行一次維護，維護頻率應視環境、氣候條件與季節做適當調整。

警告！



- 進行任何維修動作前，請確定交直流電源皆已切斷以避免觸電危險。

5.1 開啟與關閉前蓋

5.1.1 斷電程序

1. 切斷交流斷路器，並確保無機會被重新開啟。
2. 切斷太陽能匯流箱或直流匯流排上之開關，並確保無機會被重新開啟。
3. 等待60秒鐘，並確保變流器之LED指示燈熄滅。
4. 使用電流錶量測DC / AC電纜確保沒有電流。

5.1.2 開啟前蓋

注意



- 當變流器外殼處於潮濕狀態，請擦拭過後再開啟前蓋，以防水氣進入箱體。

1. 鬆開天線支架上的螺絲 (圖5-1)
2. 使用鎖扣外蓋上的六角板手鬆開鎖扣外蓋並開啟鎖扣 (圖5-1)
3. 開啟變流器前蓋並使用六角板手固定前蓋 (圖5-2)



圖 5-1：開啟與關閉前蓋



圖 5-2：利用扳手將前蓋進行固定

當安裝空間狹窄不易作業時，可以依下圖所示上抬前蓋並拆除。
作業完成後，請將前蓋安裝回變流器，並按照5.1.3章節的步驟關閉前蓋。

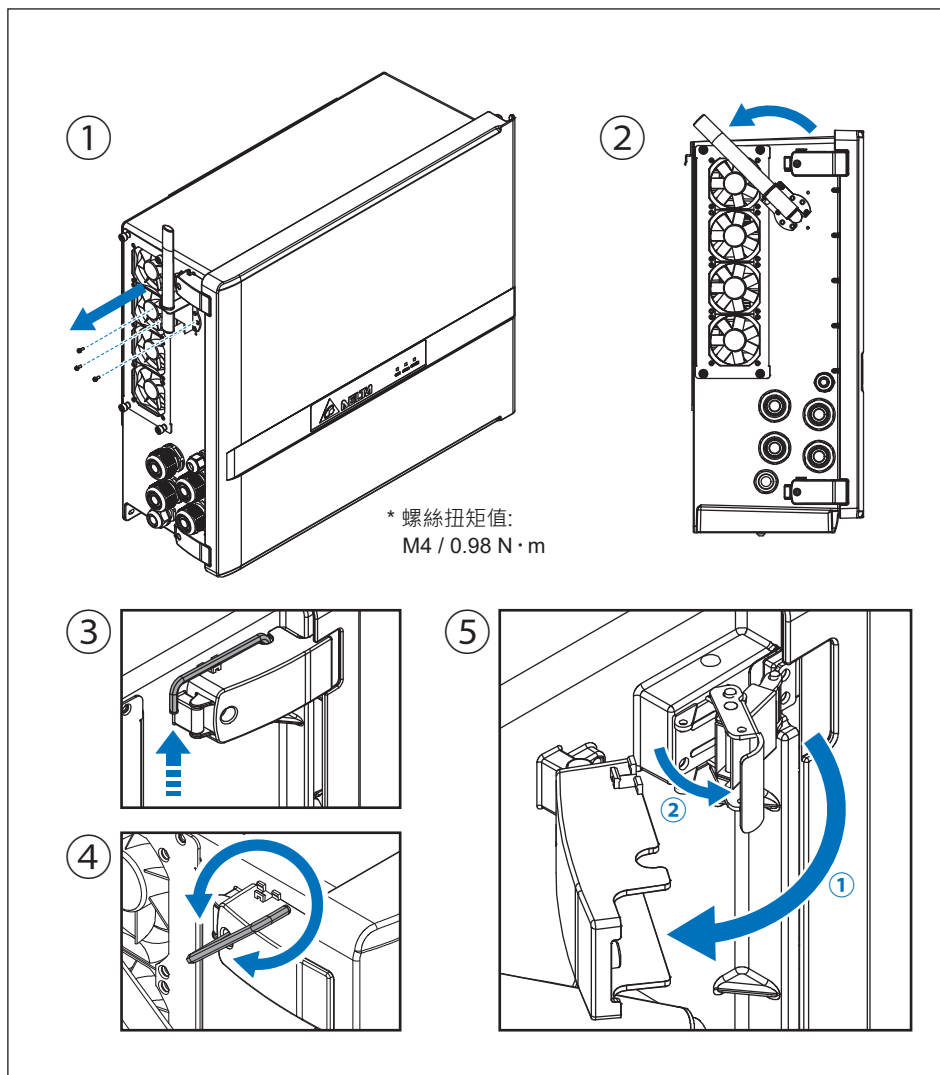

圖 5-3：拆除前蓋

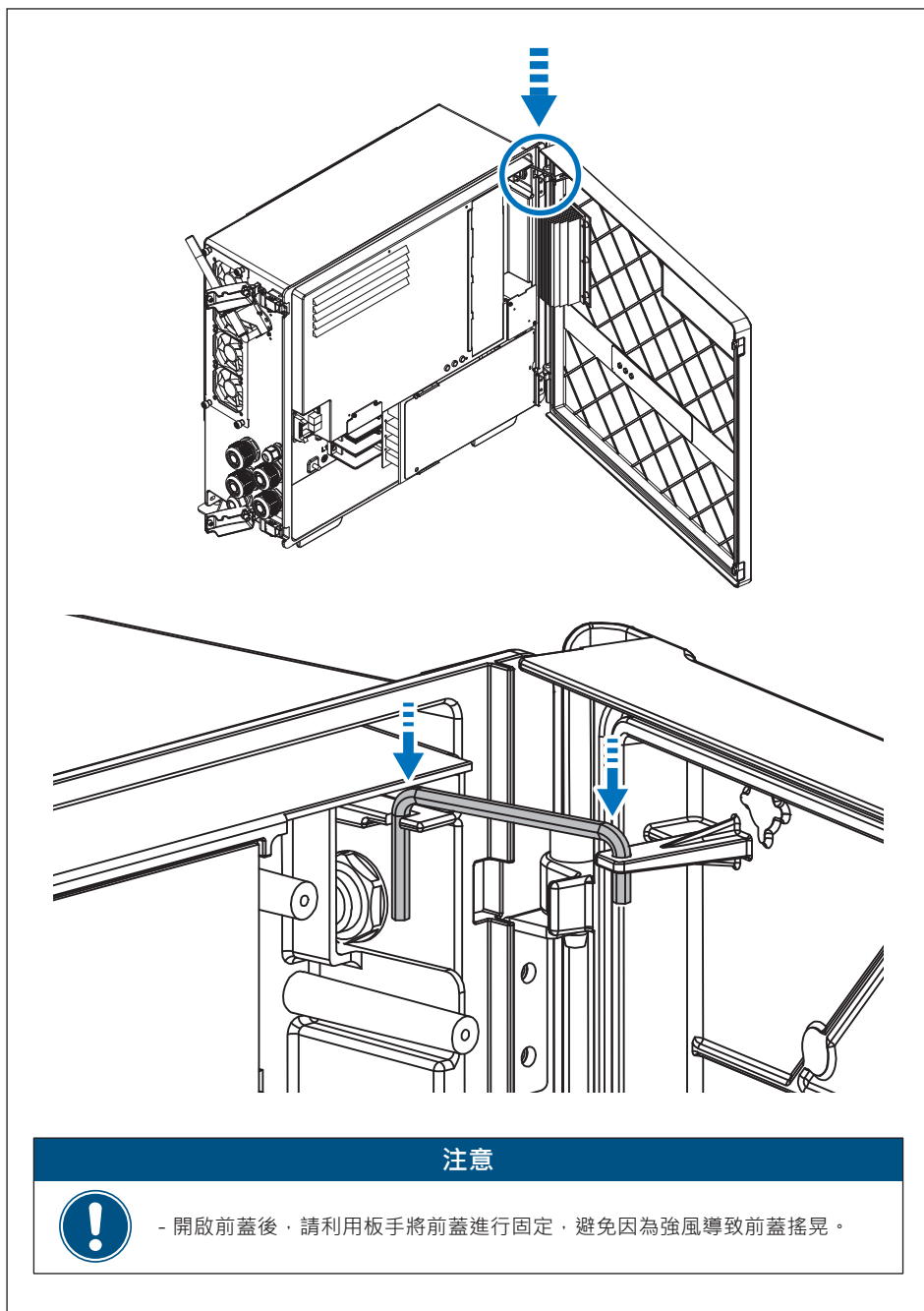
5.1.3 關閉前蓋

注意

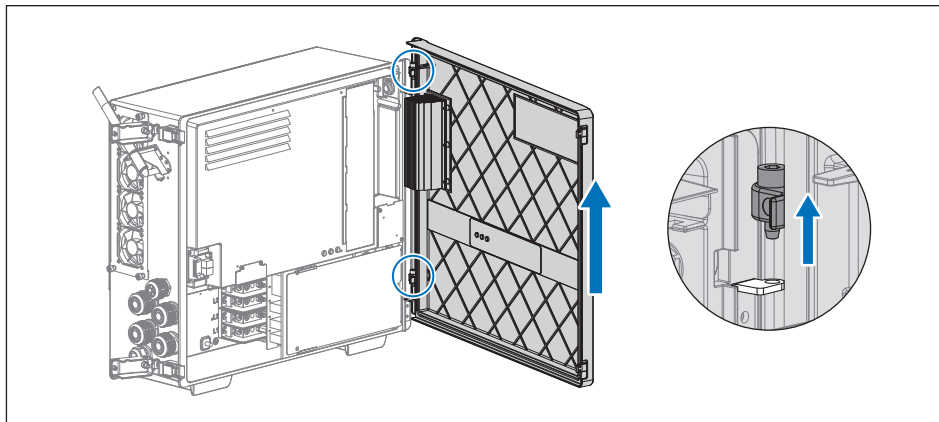

- 變流器內部若有過多水氣或灰塵進入，將導致零件損壞而降低變流器使用壽命。
- 配線或開蓋檢查作結束後，請將兩個鎖扣都確實扣上，避免機器失去IP66的防護。

1. 確保端子或可見帶電元件清潔無雜物、灰塵或液體。
2. 所有防護蓋皆正確安裝。
3. 卸下固定前蓋之六角扳手，並關閉前蓋。
4. 扣上鎖扣並以2 N·m的扭矩使用六角扳手擰緊鎖扣外蓋。
5. 將六角扳手固定於鎖扣外蓋上。
6. 將天線及支架轉正(垂直地面)並以0.98 N·m的扭矩鎖上支架螺絲。

5.2 更換雷擊保護裝置 (SPD)

M100_210配有用於交流和直連接線的雷擊保護裝置，位於內部防護蓋下方，可以在損壞時進行更換。



圖 5-4：雷擊保護裝置

5.2.1 移除雷擊保護裝置 (SPD)

1. 按照5.1.1章節步驟將電源斷開。
2. 按照5.1.2章節步驟開啟前蓋。
3. 取下直交流端子上之保護蓋，即可看見SPD。
4. 按壓端子頭後，移除感測線(圖5-6)。
5. 使用PH2螺絲起子旋鬆8顆螺絲(圖5-6)，即可卸下SPD。

5.2.2 安裝雷擊保護裝置 (SPD)

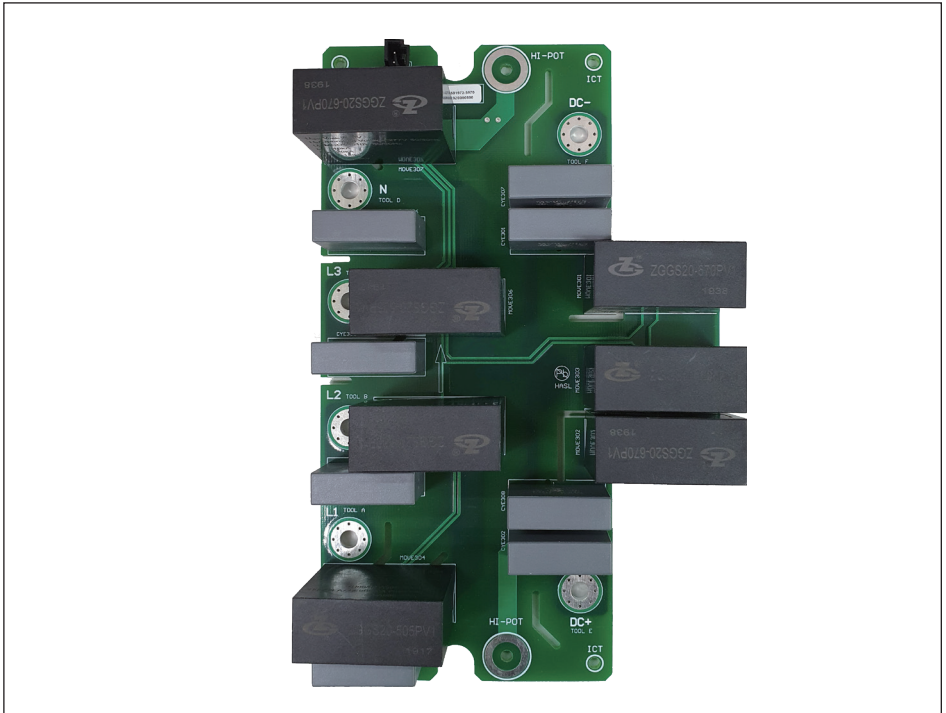
1. 確保SPD正確安裝，使孔位正確對應於直交流端子上。
2. 以0.8 N-m之扭矩，並使用PH2螺絲起子鎖緊SPD上之8顆螺絲。
3. 將感測線連接到SPD之端子上，並確保將其鎖定。
4. 裝上保護蓋，並使用PH2螺絲起子以0.8 N-m之扭矩鎖緊3個螺絲。
5. 按照5.1.3章節步驟關閉前蓋以完成SPD安裝。

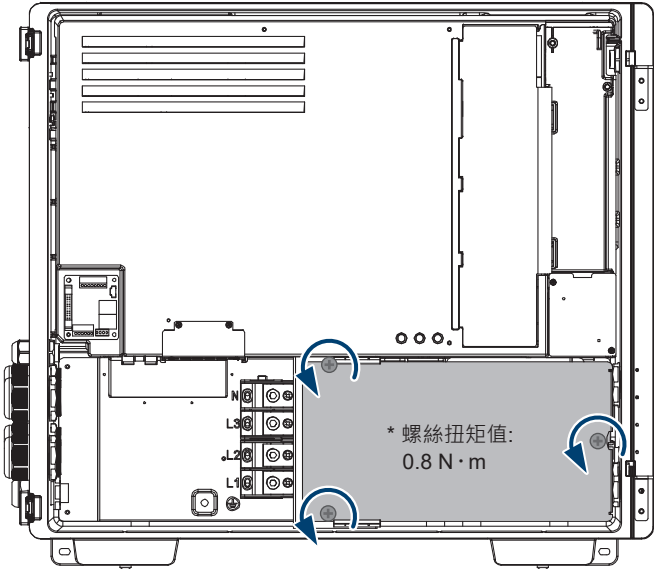

鎖附前，請先使用手動預鎖。



圖 5-5 : 取下防護蓋



圖 5-6 : 移除螺絲與排線

5.3 智慧風扇更換與濾網清潔

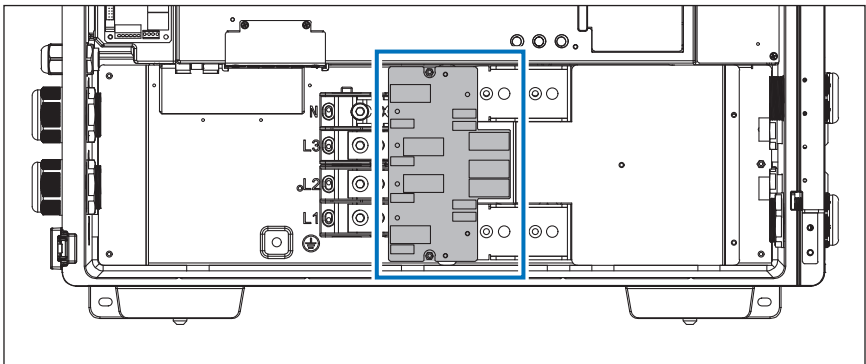
M100_210 提供一組電源冷卻風扇及兩組內部循環風扇：

圖 5-8 為功率模組風扇位置。

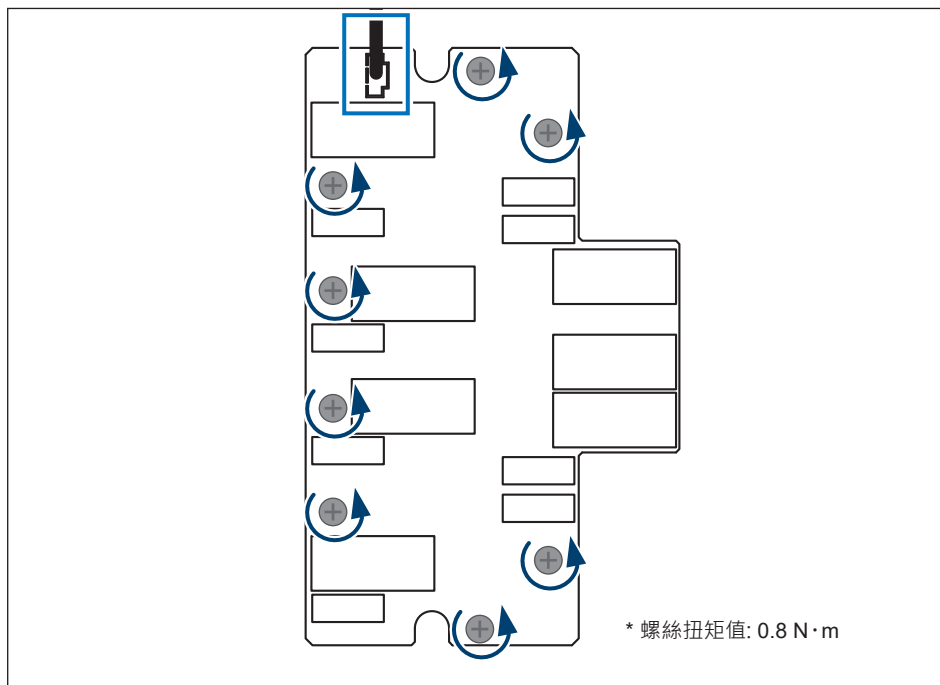
圖 5-9, 5-10, 5-11 為內部風扇1的位置。

圖 5-12, 5-13, 5-14 為內部風扇2的位置。

注意



需要定期的將風扇和過濾器清潔，以確保長壽命和可靠性。

- 風扇及濾網清潔頻率由當地環境決定。
- 正常環境條件使用下，每四個月需清潔風扇及濾網一次。
- 若安裝於嚴苛環境，建議每個月或每一季需清潔風扇及濾網一次。

因該冷卻系統採用模組化設計，因此具有易清潔與易維護更換的特性。

危險:觸電危險!!



- 在開始任何維護程序之前，請將交流斷路器和直流開關關閉以避免電擊危險！

5.3.1 風扇告警對應位置

當警告訊息顯示 "W11-Fan Fail"，請參考DSS上的錯誤代碼並依循以下章節的步驟，更換對應位置的風扇。



圖 5-7 : DSS錯誤代碼對應之風扇位置

5.3.2 功率模組專用風扇

請參閱圖5-8並按照下面列出的步驟操作：

- 卸入風口過濾網外蓋的四顆螺絲。
此步驟進行後，同時確認過濾網狀態，必要時進行清潔。
進行風扇維護時，請繼續執行以下步驟。
- 取下每個風扇電源排線。(要釋放卡扣，請從兩側按位置A和位置B。)
- 從機箱中取出風扇托盤。
要單獨拆卸風扇時，請卸下其固定到風扇托架的四顆螺釘。
重新安裝風扇架時，請按照上述步驟的順序重新組裝並鎖緊螺絲。

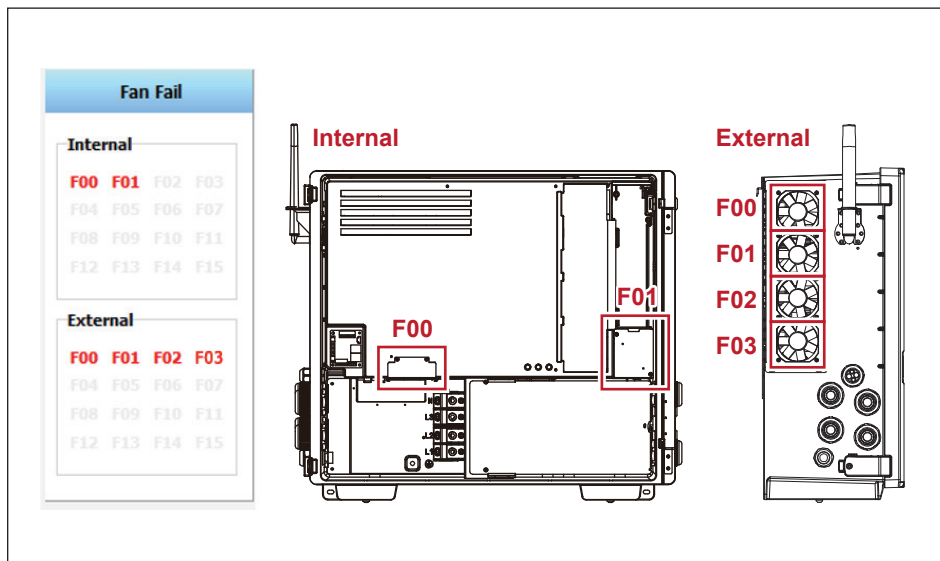
* 螺絲扭矩值: 1.4 N·m

①

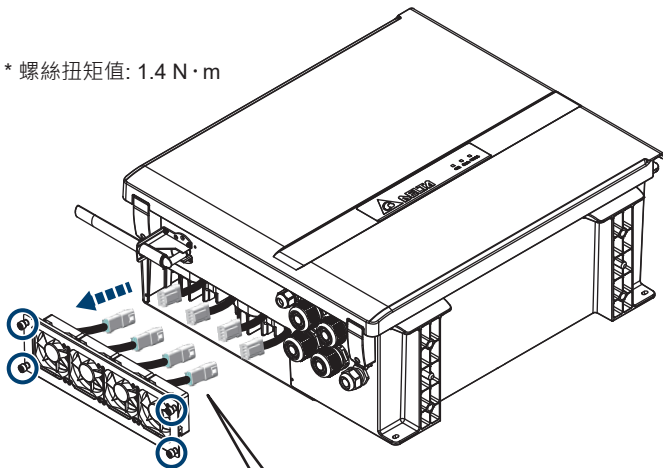

②

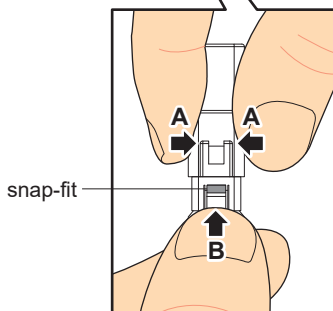

③

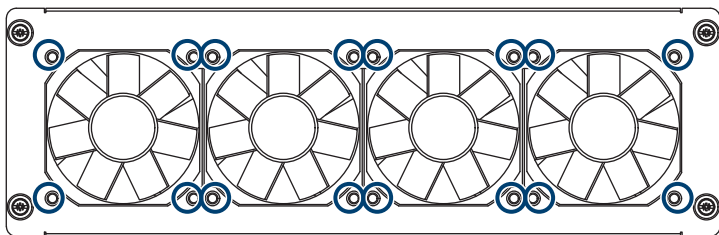

* 螺絲扭矩值: 0.6 N·m

圖 5-8 : 風扇架拆卸示意圖

5.3.3 內部風扇1

拆裝內部風扇1步驟

- (1) 依照圖5-9上圖所示拆下B蓋。
- (2) 鬆開圖5-9下圖中的兩顆防脫落螺絲，然後拆下風扇架。
- (3) 取下DC SPD板上的電源連接排線。
- (4) 取下風扇組件。(如圖5-10所示)
- (5) 清潔風扇組件或更換新風扇。(如圖5-11所示)
- (6) 使用圖中所示的扭矩重新組裝。



圖 5-9：內部風扇1 位置與拆裝示意圖



圖 5-10：取下內部風扇1示意圖

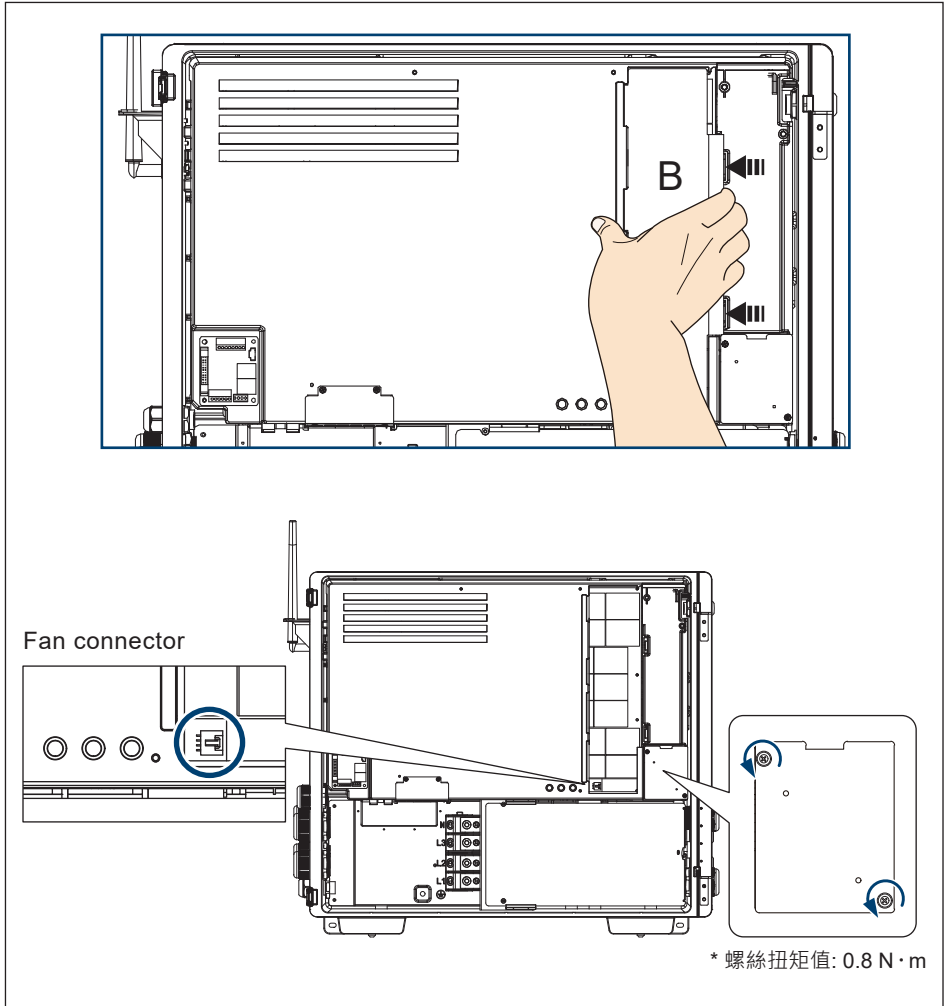

圖 5-11：更換風扇示意圖

5.3.4 內部風扇2

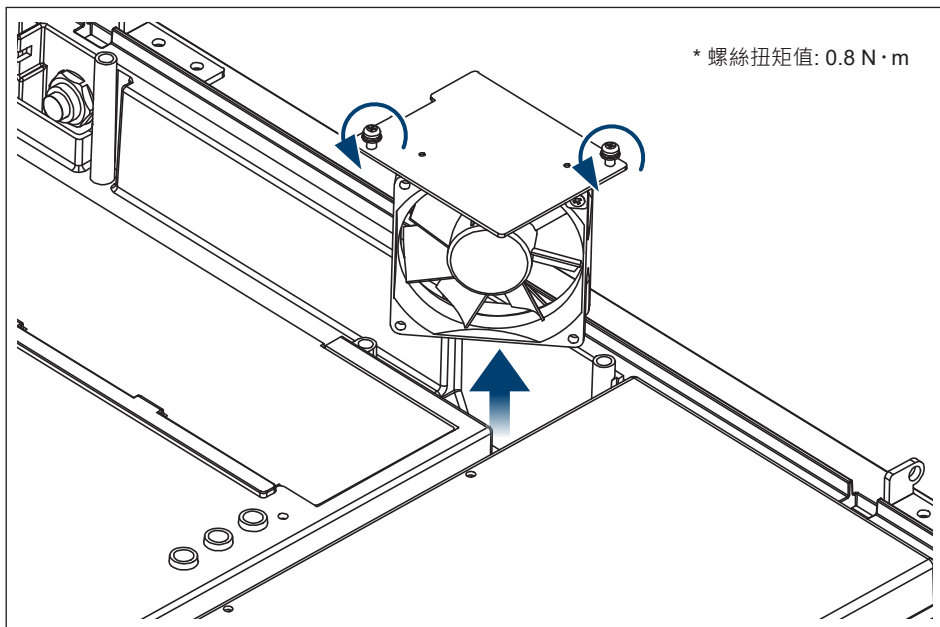
拆裝內部風扇2步驟

- (1) 鬆開圖5-12中所示的兩顆防脫落螺絲，然後拆下風扇架。
- (2) 取下通訊板上的電源連接排線。
- (3) 取下風扇組件。(如圖5-13所示)
- (4) 清潔風扇組件或更換新風扇。(如圖5-14所示)
- (5) 使用圖中所示的扭矩重新組裝。

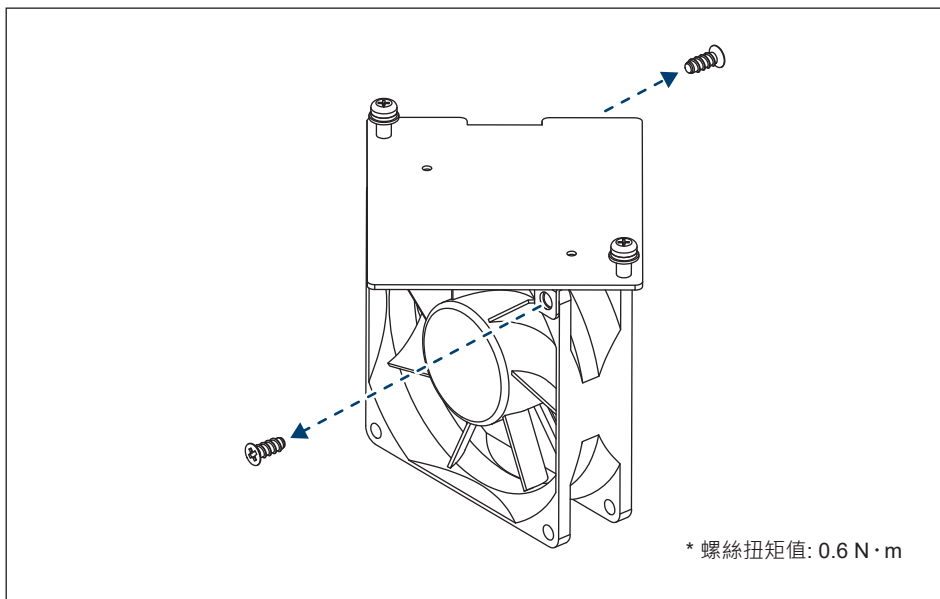

圖 5-12：內部風扇2 位置與拆裝示意圖

* 螺絲扭矩值: $0.8 \text{ N} \cdot \text{m}$

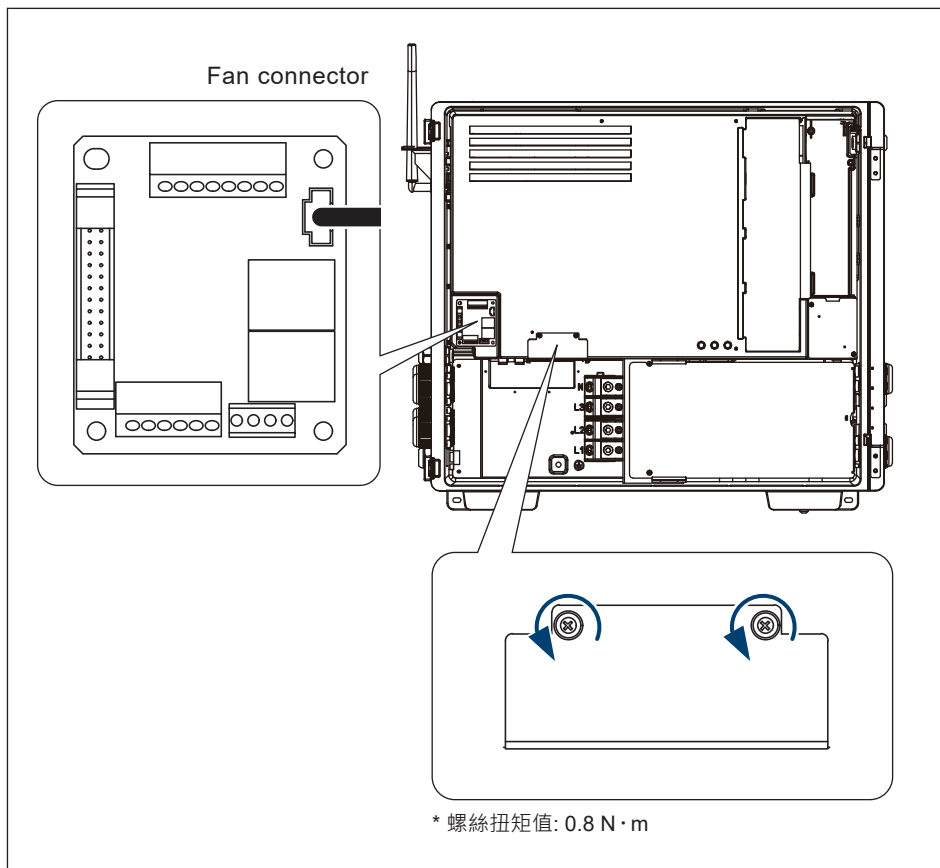

圖 5-13：取下內部風扇2示意圖

* 螺絲扭矩值: $0.6 \text{ N} \cdot \text{m}$

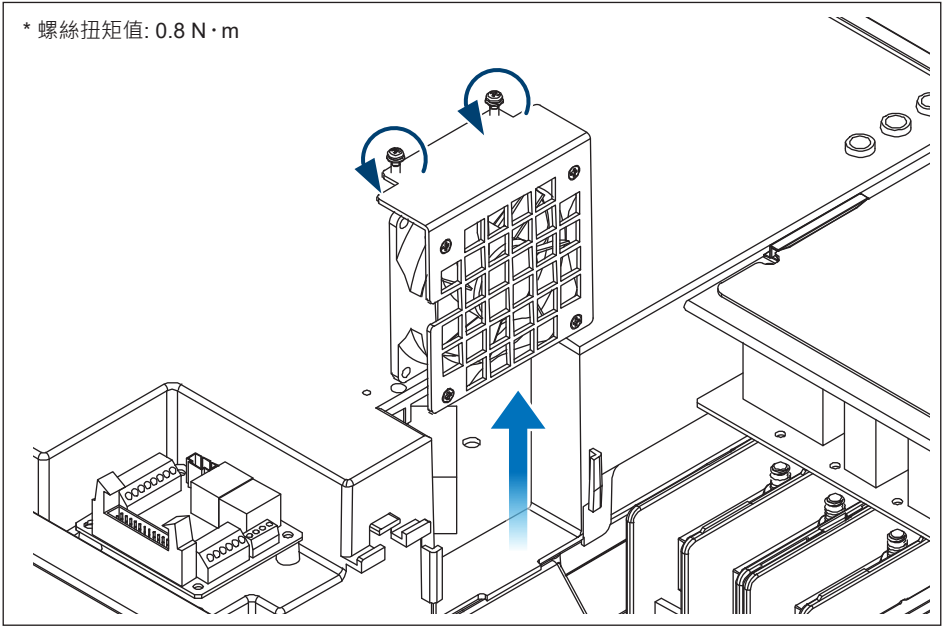

圖 5-14：更換風扇示意圖

5.4 終止運轉

危險:觸電危險!!

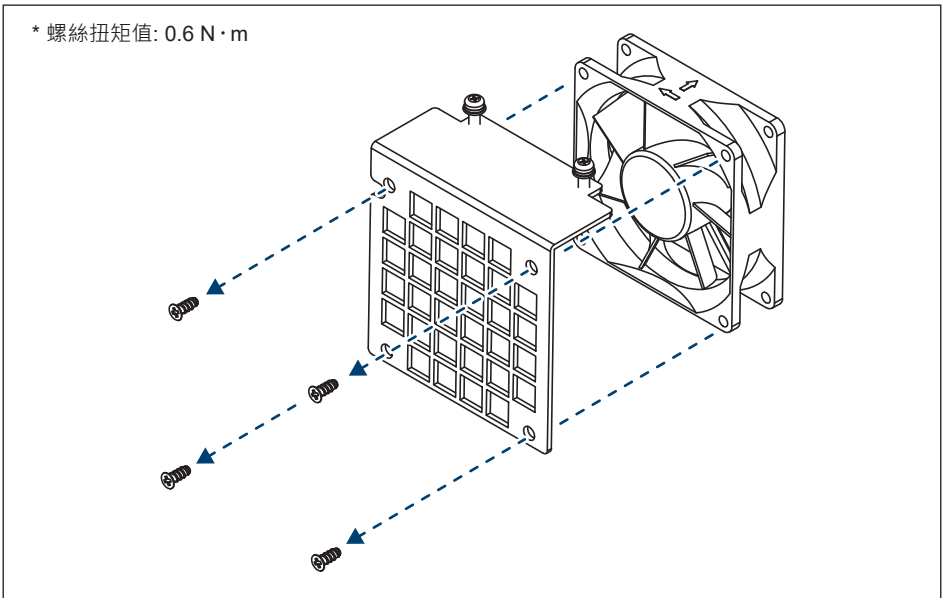

- 確保交流電源線於操作過程中沒有電力來源，以避免觸電危險。

注意: 表面高溫!



- 變流器表面高溫可能導致人員受傷，請在觸碰前確保已冷卻至適當溫度範圍。

機器停止運轉步驟如下:

1. 請遵循5.1.1章節步驟切斷電源
2. 請遵循5.1.2章節步驟開啟前蓋
3. 移除通訊、直流、交流及接地電纜

注意



- 所有電纜都應做適當絕緣防護。

4. 妥善安裝電纜密封套內部橡膠墊圈及防水塞，以防水氣及灰塵進入機體內部

6 錯誤告警及排除問題

台達致力於打造高可靠標準的電子產品，若出現變流器無法正常動作的情況時，請使用故障排除指南(表6-1~6-4)中的說明，進行故障排除；若經過排除後仍無法解決問題，請聯繫客服中心尋求技術協助。

6.1 錯誤訊息(配置端故障)

表 6-1A: 錯誤訊息 (配置端故障)

資訊顯示	可能原因	故障排除
AC Freq High (E01)	市電頻率過高	1. 檢查變流器端的市電頻率 2. 檢查國家與電網設定
AC Freq Low (E02)	市電頻率過低	
Island (E03,E04,E05)	市電中斷	檢查AC 斷路器
AC phase jump (E06)	市電相位異常	當重複發生時，請聯繫客服人員，尋求技術支援
Grid Quality (E07)	在電網或靠近變流器附近非線性的負載	當重複發生時，請聯繫客服人員，尋求技術支援
AC phase abnormal (E08)	AC端連接錯誤	檢查AC連接，必須和使用手冊一致
No Grid (E09)	1. AC 斷路器跳開 2. AC 接頭未正確連接	1. 斷開AC 斷路器 2. 檢查連接AC接頭並確認其連接至變流器
AC Volt Low (E10)	1. 市電電壓過低 2. 電網設定錯誤 3. AC端連接錯誤	1. 檢查市電與變流器端的連接 2. 檢查國家或電網設定 3. 檢查AC接頭連接
AC Volt High (E11)	1. 市電電壓過高 2. 電網設定錯誤	
EPO (E25)	緊急關斷按鈕被啟動	請解除EPO按鈕
DC Volt High (E30)	輸入電壓超過 1000Vdc	修正solar array設定並使得Voc小於1000Vdc
Insulation Fault (E34)	太陽能模組與接地間發生隔離阻抗問題	1. 檢查太陽能模組接地是否確實 2. 檢查變流器接地是否確實 3. 檢查直流斷路器是否受潮
Remote OFF (E36)	外部通訊執行遠端關機	請檢查外部通訊Remote OFF設定

6.2 故障代碼(變流器故障)

表 6-2A: 錯誤訊息 (變流器故障)

資訊顯示	可能原因	故障排除
DC Injection (F01,F02,F03,F04)	市電波形異常	請聯繫客服人員，尋求技術支援
Temperature High (F05)	變流器內部環溫或功率模組溫度過高	檢查設備的周遭和環境
Amb Temp Fault (F06)	功率模組溫度偵測電路異常	請聯繫客服人員，尋求技術支援
Temperature Low (F07)	變流器內部環溫或功率模組溫度過低	檢查設備的周遭和環境
Boost Temp Fault (F08)	功率模組溫度偵測電路異常	請聯繫客服人員，尋求技術支援
Bidir. Temp Fault (F09)	功率模組溫度偵測電路異常	請聯繫客服人員，尋求技術支援
Inveter Temp Fault (F10)	功率模組溫度偵測電路異常	請聯繫客服人員，尋求技術支援
AC RLY Fault (F13)	1. 繼電器驅動電路異常 2. 繼電器異常	請聯繫客服人員，尋求技術支援
FW Unmatch (F14)	韌體不相容	請聯繫客服人員，尋求技術支援
AC Sensor Fault (F15)	輔助電源電路異常	1. 請確認直流端子極性(當同時出現W08時) 2. 請聯繫客服人員，尋求技術支援
Vdc Sensor Fault (F16)	輔助電源電路異常	請聯繫客服人員，尋求技術支援
Idc Sensor Fault (F17)	輔助電源電路異常	1. 請確認直流端子極性(當同時出現W08時) 2. 請聯繫客服人員，尋求技術支援
AC Sensor Fault (F18)	輔助電源電路異常	1. 請確認直流端子極性(當同時出現W08時) 2. 請聯繫客服人員，尋求技術支援
Idc Sensor Fault (F19)	輔助電源電路異常	請聯繫客服人員，尋求技術支援
Red COMM Fault (F22)	變流器內部通訊異常	請聯繫客服人員，尋求技術支援
DSP COMM Fault (F23)	變流器內部通訊斷線	請聯繫客服人員，尋求技術支援

表 6-2B: 錯誤訊息 (變流器故障)

資訊顯示	可能原因	故障排除
Ground Cur. High (F24)	太陽能模組與接地隔離阻抗異常	1. 檢查輸入端的絕緣 2. 請聯繫客服人員，尋求技術支援
Iac Unbalance (F26)	1. 變流器內部的電源線未連接 2. 電流回授電路無效	檢查AC接頭連接
RCMU Fault (F27)	RCMU連接中斷	請聯繫客服人員，尋求技術支援
AC RLY Short (F28)	AC 繼電器短路	請確認端子座配線與市電端配線是否正確
AC RLY Open (F29)	AC 繼電器開路	請聯繫客服人員，尋求技術支援
Bus Unbalance (F30)	變流器內部直流電壓不平衡	重新啟斷DC開關
Bus Voltage High (F31, F32, F33, F34, F35)	Bus 電容電壓過高	1. 請重新啟動DC開關 2. 修正太陽能板設定，並使得Voc 小於 1000Vdc (當同時出現E30時)
AC Current High (F36, F37, F38, F39, F40, F41)	操作期間突波發生	請聯繫客服人員，尋求技術支援
AC CT Fault (F42)	交流側R相電流感測器異常	請聯繫客服人員，尋求技術支援
AC CT Fault (F43)	交流側S相電流感測器異常	請聯繫客服人員，尋求技術支援
AC CT Fault (F44)	交流側T相電流感測器異常	請聯繫客服人員，尋求技術支援
AC Current High (F45)	交流電流輸出過大	重新啟斷DC開關
ZC Circuit Fault (F50)	相位偵測電路異常	請聯繫客服人員，尋求技術支援
Inv Circuit Fault (F51)	電壓轉換電路異常	請聯繫客服人員，尋求技術支援
Boost Circuit Fault (F52)	升壓電路異常	請聯繫客服人員，尋求技術支援
Arc Circuit Fault (F58)	1. 電弧偵測硬體異常 2. 電弧偵測測試異常	請檢查電弧偵測電路，確認接線正確
Arc Fault (F59)	變流器偵測到電弧異常	1. 請檢查直流側接線有無異常或毀損 2. 更換直流側接線並到DSS解除ARC鎖機狀態 3. 請聯繫客服人員，尋求技術支援

表 6-2C: 錯誤訊息 (變流器故障)

資訊顯示	可能原因	故障排除
DC Current High (F60,F61,F70,F71)	直流端過電流保護	重新啟斷DC開關
Ext COMM. Fault (F74)	外部通訊異常	1. 請檢查外部通訊接線是否異常 2. 請聯繫客服人員，尋求技術支援

6.3 警告代碼(配置端警告)

表 6-3A: 警告代碼 (配置端警告)

資訊顯示	可能原因	故障排除
De-rating (W07)	<ol style="list-style-type: none"> 1. 本體及環境溫度過高 2. 實功率限制功能作動 3. P-F功能作動 4. P(V) 功能作動 5. 市電電壓過低 6. 輸入電壓過低 7. 輸入電壓過高 8. 爬升功能 	<ol style="list-style-type: none"> 1. 確認安裝機器本體及環境溫度 2. 確認國別及最大功率限制參數設定 3. 確認市電頻率是否異常 4. 確認市電電壓是否異常 5-1. 確認市電電壓是否異常 5-2. 確認虛功控制功能設定 6. 確認PV panel輸入電壓是否過低 7. 確認PV panel輸入電壓是否過高 8. 確認爬升功能設定
String fault (W08)	<ol style="list-style-type: none"> 1. 直流端子極性錯誤 2. 太陽能組串不匹配 3. 組串電流偵測電路異常 	<ol style="list-style-type: none"> 1. 確認直流端子極性 2. 確認PV panel各組串的開路電壓是否異常 3. 請重開直流開關與交流斷路器 4. 請聯繫客服人員，尋求技術支援
String Current Low (W23)	DC端子連接異常	<ol style="list-style-type: none"> 1. 請檢查直流配線與保險絲 2. 請聯繫客服人員，尋求技術支援

6.4 警告代碼(變流器警告)

表 6-4A: 警告代碼 (變流器警告)

資訊顯示	可能原因	故障排除
Fan Fail (W11)	<ol style="list-style-type: none"> 1. 一個或多個風扇鎖死 2. 一個或多個風扇無效 3. 一個或多個風扇未連接 	請聯繫客服人員，尋求技術支援
DC SPD Fault (W17) AC SPD Fault (W18)	一個或多個DC/AC SPD無效	<ol style="list-style-type: none"> 1. 檢查DC/AC SPD的連接線 2. 更換DC/AC SPD板
Boost Circuit Fault (W30)	升壓電路故障	請聯繫客服人員，尋求技術支援

7 技術資料

表 7-1A: 規格

Model	M100A_210
直流輸入	
最大輸入電壓	1100 V *1
工作電壓範圍	550 - 1000 V
MPP 電壓範圍 @ AC 380V	590 - 860 V *2
啟動電壓	610 V @ AC 400V / 585 V @ AC 380V
輸入電壓	550 V
最大輸入電流	185 A
最大輸入功率	113.5 kW
允許最大短路電流	250 A
MPP 追蹤	1
接頭種類	接線銅排, Max. 185mm ² Cu and Al conductor
雷擊保護	Type II SPD (標配) ; Type I+II SPD (選配)
電弧偵測功能	標配
交流輸出	
最大輸出視在功率	110 kVA when AC voltage \geq 400 V *3 105 kVA when AC voltage is 380 V *4
最大輸出實功功率	110 kW when AC voltage \geq 400 V 105 kW when AC voltage is 380 V
輸出功率	100 kW @ 50°C ; 105 kW @ 40°C
最大輸出電流	160 A
輸出電流	380 V, 3Ø3W or 3Ø4W
工作電壓範圍	80% to 130% of 交流電壓
夜間虛功功能	60 kVAR
工作頻率範圍	50 / 60Hz \pm 5Hz
功率因數 (可調)	0.8 ind - 0.8 cap
雷擊保護	Type II SPD (標配) ; Type I+II SPD (選配)
T.H.D	< 3% at Rated output current
接頭種類	端子台形式, Max. 185 mm ² Cu and Al conductor
夜間耗電 *5	< 3.5 W

*1 本產品可承受最高電壓為1100Vdc, 但超過1000Vdc時變流器會停止輸出。

*2 環境溫度 < 15°C: 550~860Vdc; 環境溫度 < 30°C: 550~840Vdc; 環境溫度 < 40°C: 550~760Vdc

*3 環境溫度 < 33°C, 直流輸入電壓 < 840Vdc

*4 環境溫度 < 31°C, 直流輸入電壓 < 840Vdc

*5 使用RS-485通訊情況下

表 7-1B: 規格		
Model	M100_210	
效率		
最高效率	99.0 %	
歐洲效率	98.7 %	
資訊		
通訊介面	RS-485 (標配) ; SUB_1G / Wi-Fi (選配)	
規範認證		
併網認證	IEC 62109-1/-2 IEC 62116 EN 61000-6-2 VPC	IEC 61727 IEC 61683 EN 61000-6-3
一般數據		
操作溫度範圍	-25 to +60°C (超過 50°C 智慧降載)	
防水防塵等級	IP66	
操作海拔範圍	< 4000 m	
冷卻模式	Smart fan air cooling	
噪音	65.2 dBA @1m, Amb25°C	
尺寸 (W x H x D)	699 x 629 x 264 mm	
重量	67 kg	



圖 7-1: 效率曲線圖



圖 7-2: 環溫對應降額曲線圖(400 Vac)

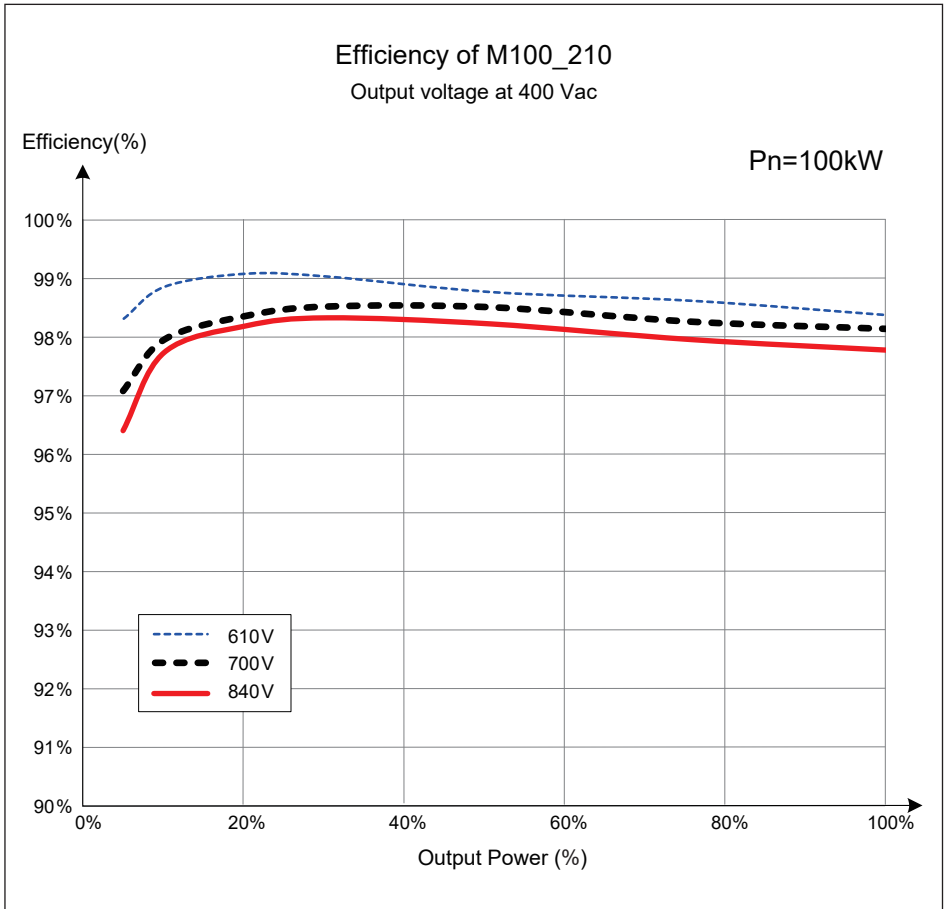

圖 7-3: 環溫對應降額曲線圖(380 Vac)

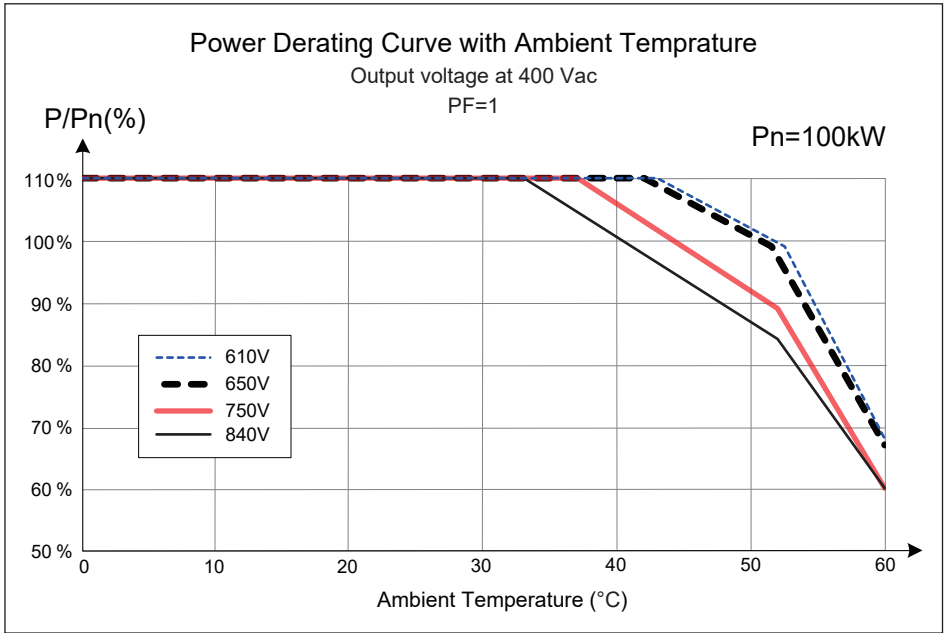

圖 7-4: 環境溫度對應輸出能力降額曲線

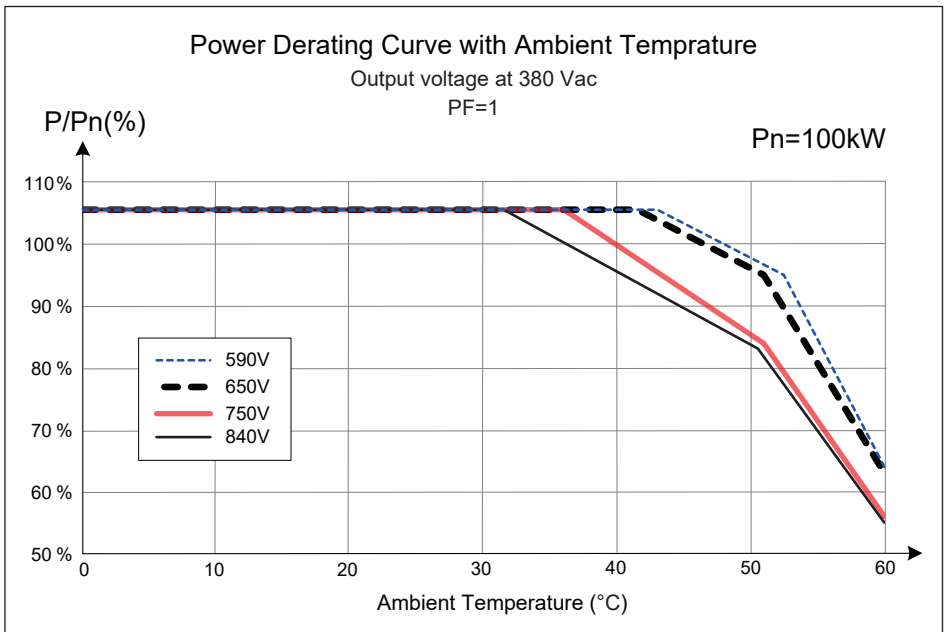

圖 7-5: 環溫對應視在功率降額曲線圖

附錄: 組裝說明

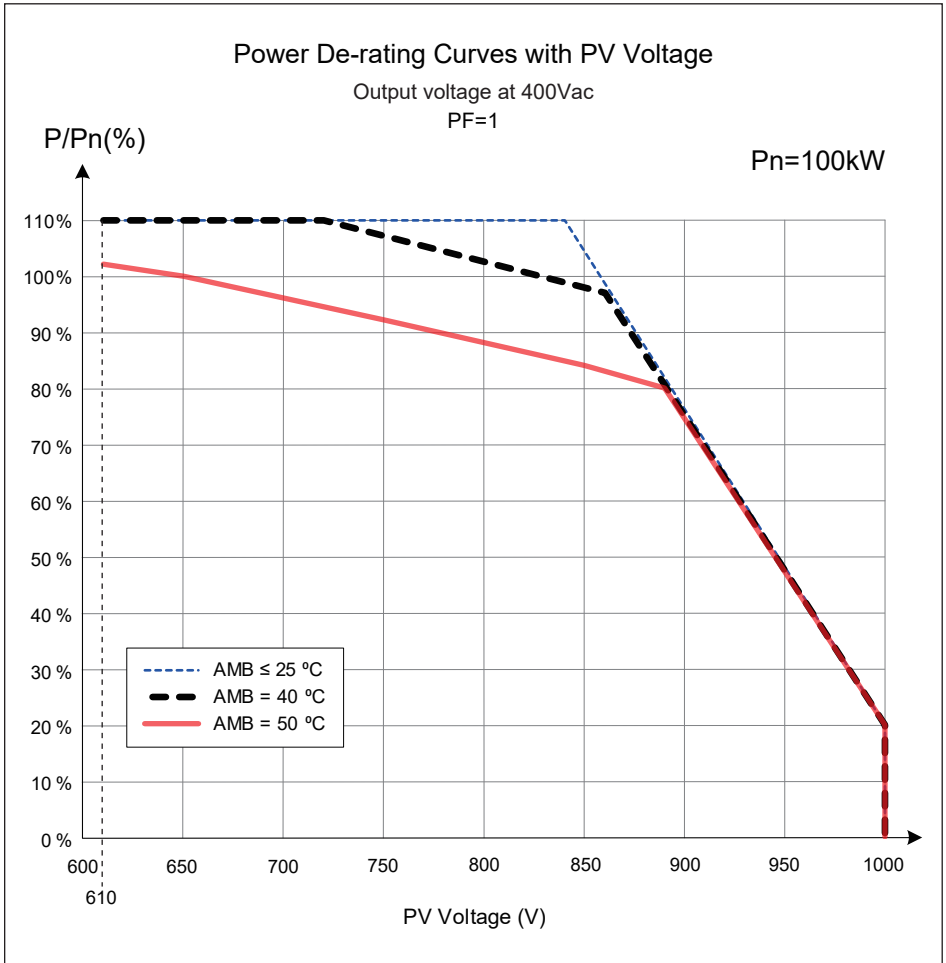

附錄-1: 組裝說明-1

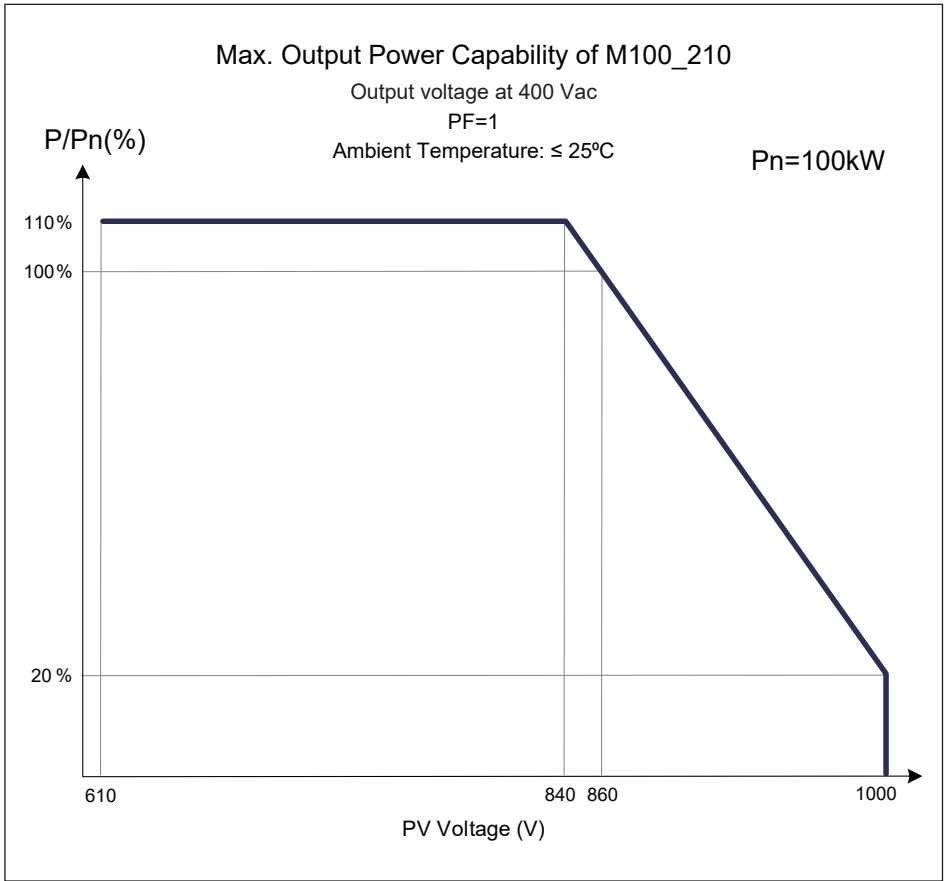
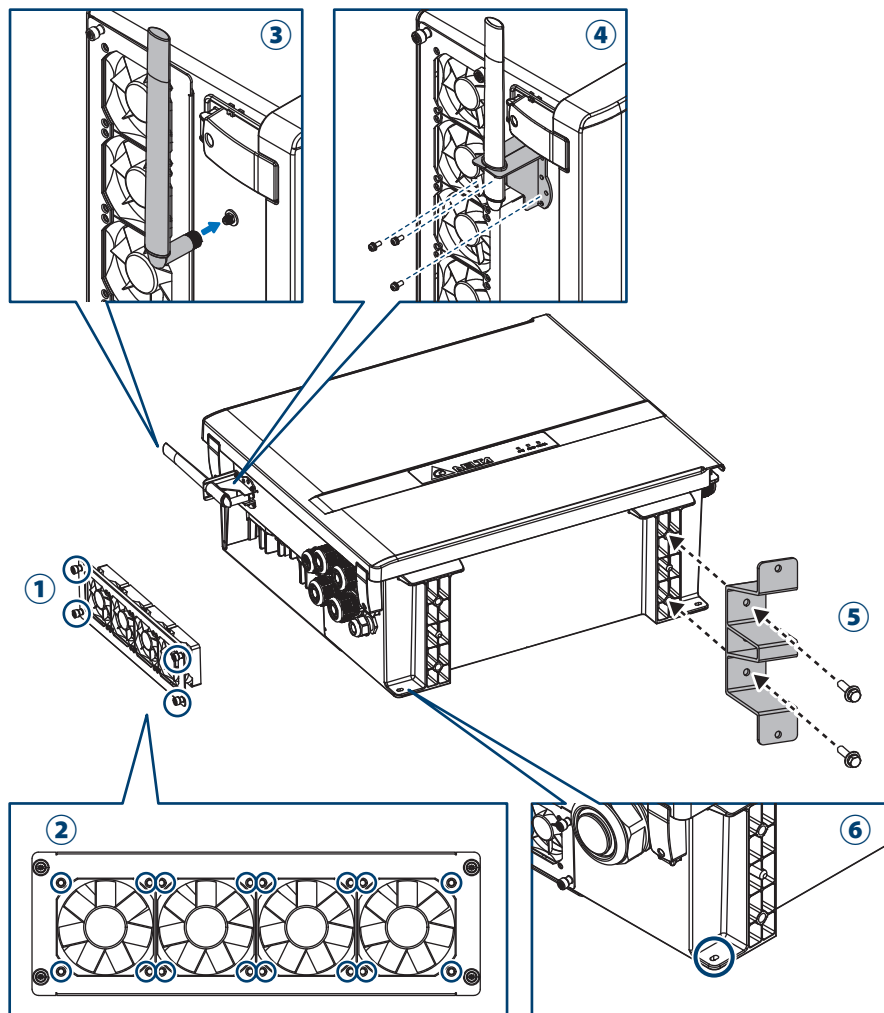
NO	位置	螺絲扭力
1	濾網外蓋	14 kgf-cm (1.4N·m)
2	風扇托盤	6 kgf-cm (0.6N·m)
3	天線	12 kgf-cm (1.2N·m)
4	天線支架 (M4)	10 kgf-cm (0.98N·m)
5	落地支架	250 kgf-cm (24.5N·m)
6	設備接地 (M8)	102 kgf-cm (10N·m)

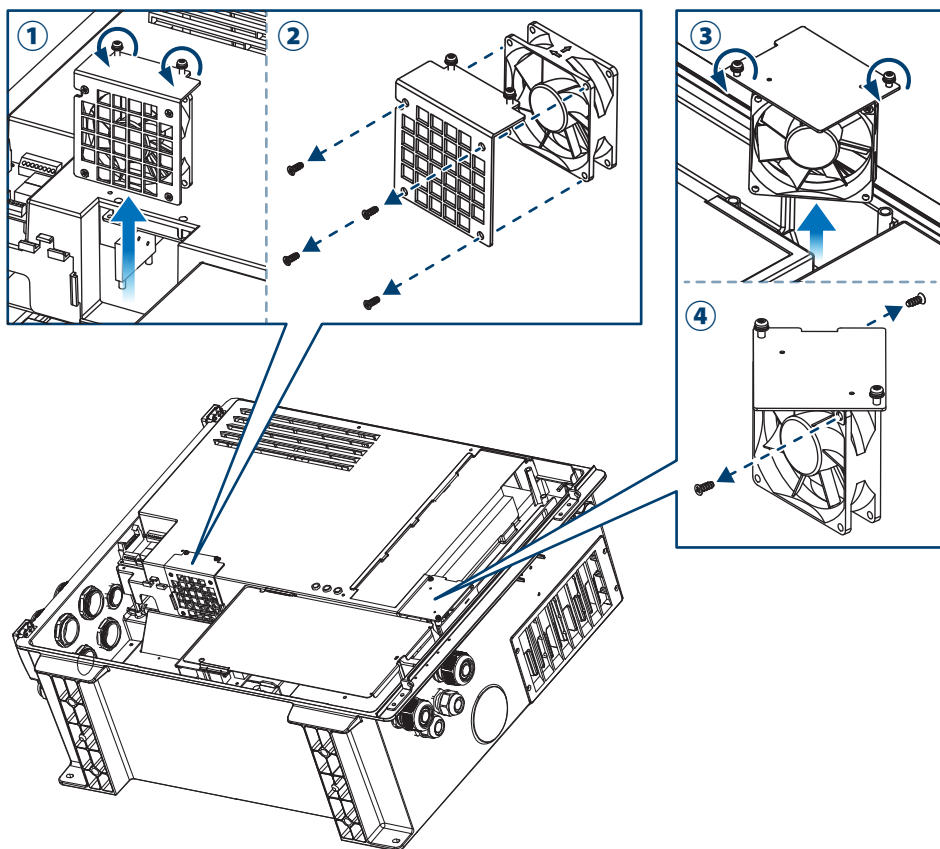

附錄-2: 組裝說明-2

NO	位置	螺絲扭力
1	內部風扇架 2	8.0 kgf-cm (0.8N · m)
2	內部風扇組件 2	6.0 kgf-cm (0.6N · m)
3	內部風扇架 1	8.0 kgf-cm (0.8N · m)
4	內部風扇組件 1	6.0 kgf-cm (0.6N · m)

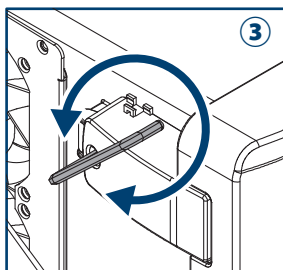
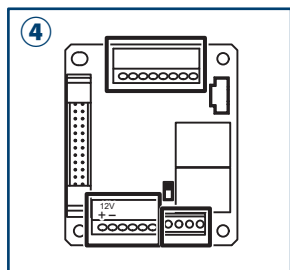
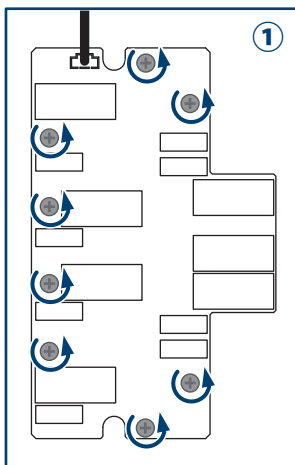
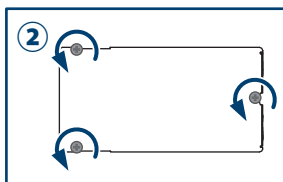
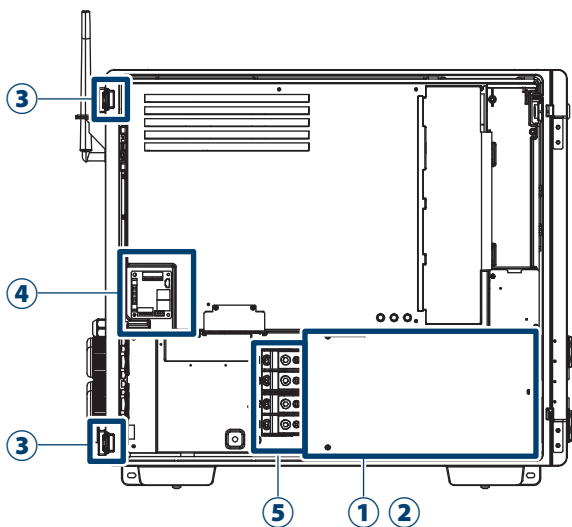

附錄-3: 組裝說明-3

NO	位置	螺絲扭力	導體橫截面
1	雷擊保護裝置	A: 25 kgf-cm (2.45 N·m)	-
2	交流絕緣蓋	8.0 kgf-cm (0.8 N·m)	-
3	鎖扣外蓋	25 kgf-cm (2.45 N·m)	-
4	通訊模組	-	20 AWG (0.5 mm ²)
5	交流端子	L1, L2,L3,N	70 mm ² ~185 mm ²
		PE	120 mm ²

