



The power behind competitiveness

Grid-tie Transformerless Solar Inverter

M80U

M60U

Operation and Installation Manual

www.deltaww.com

 **DELTA**
Smarter. Greener. Together.

Table of Contents

- 1 Safety 10**
 - 1.1 Information of the Inverter 10
 - 1.1.1 Legal Provisions 10
 - 1.1.2 Target Group 10
 - 1.2 General Safety 11
 - 1.2.1 Condition of Use 11
 - 1.2.2 Symbols 12
- 2 Introduction 14**
 - 2.1 Valid Model 14
 - 2.2 Product Overview 15
- 3 Installation 24**
 - 3.1 Mechanical Installation 24
 - 3.1.1 Vertical wall mount 24
 - 3.1.2 Horizontal or Tilt mount 25
 - 3.1.3 Mounting Bracket 27
 - 3.1.3.1 New Models With New Version of Mounting Bracket 28
 - 3.1.3.2 Old Models With New Version of Mounting Bracket 30
 - 3.1.4 Accessories 35
 - 3.2 Wiring box cover 38
 - 3.3 Electrical Installation for AC Wiring 38
 - 3.3.1 AC Grid Types and Connections 39
 - 3.3.2 Required Protective Devices for M80U / M60U 39
 - 3.3.3 AC wiring preparation (all models) 39
 - 3.3.4 AC Switch Terminals –Prewire set-up 40
 - 3.3.5 AC Wiring for M80/60U_120 models 42
 - 3.3.6 AC Wiring for M80/60U_121 models (With RSD) 44
 - 3.3.7 AC Wiring for M80/60U_121 models (Without RSD) 45
 - 3.3.8 AC Wiring for M80/60U_122 models 46
 - 3.4 Electrical Installation for DC Wiring 47
 - 3.4.1 DC Wiring Installation for M80/60U_120 models 48
 - 3.4.2 DC Wiring Installation for M80/60U_121 models 50
 - 3.4.3 DC Wiring Installation for M80/60U_122 models 53
 - 3.4.4 Ground bar locations 55
 - 3.4.5 DC side ground bar for 121/122 models 56
 - 3.5 Communication Module Connections 57
 - 3.5.1 Accessing the Communication Module 58
 - 3.5.2 RS-485 Connection 59

3.5.3	EPO Function & Digital Input	61
3.5.4	Rapid shutdown system connection	62
3.6	On-site insulation test	63
4	Commissioning	64
4.1	Display Operation Introduction	64
4.2	First startup	66
4.2.1	Home Page	67
4.3	Main Menu	67
4.3.1	Power meter	68
4.3.2	String monitoring (M80/60U_122)	68
4.3.3	Energy Log	69
4.3.4	Event Log	69
4.3.5	Inverter Information	70
4.3.6	General Settings	70
4.3.7	Install Settings	71
4.3.7.1	Inverter ID	72
4.3.7.2	Insulation	72
4.3.7.3	Grid Code	72
4.3.7.4	Grid Settings	73
4.3.7.5	Potential Induced Degradation	74
4.3.7.6	Residual Current Monitoring Unit (RCMU)	74
4.3.7.7	Emergency Power-Off Enable	75
4.3.7.8	AC Connection	75
4.3.7.9	Anti-Islanding	75
4.3.7.10	DC Arc Fault Circuit Interrupter (AFCI)	76
4.3.7.11	Grid code confirm	76
4.3.8	Active / Reactive power	77
4.3.8.1	Power Limit	77
4.3.8.2	Power vs. Frequency	78
4.3.8.3	P(V)	79
4.3.8.4	Constant cosphi	79
4.3.8.5	Cosphi (P)	80
4.3.8.6	Constant Q	81
4.3.8.7	Q(V)	81
4.3.9	FRT (Fault ride through)	82

- 5 Maintenance 83**
 - 5.1 Removing and re-installing the Wiring Box (WB) cover 83
 - 5.1.1 Removing the WB cover 84
 - 5.1.2 Re-installing the WB cover 84
 - 5.2 Replacement of Surge Protection Devices (SPD) 85
 - 5.3 Replace Internal String Fuse 90
 - 5.4 Smart Fans Replacement and Filter Cleaning 94
 - 5.4.1 Wiring Box (WB) compartment fan 97
 - 5.4.2 Power Module (PM) Fan Tray 98
 - 5.4.2.1 PM Fan Tray removal procedure 98
 - 5.4.2.2 Procedures to remove PM air inlet filter 100
 - 5.5 Release AFCI Fault Protection 100
 - 5.6 De-Commissioning 101
- 6 Error message and Trouble Shooting 103**
 - 6.1 Error Codes 103
 - 6.2 Warning Codes 104
 - 6.3 Fault Codes 105
 - 6.4 Calling for Help 109
 - 6.4.1 Service Call Checklist 109
- 7 Technical Information 110**
 - 7.1 Technical of M80U series 110
 - 7.2 Technical of M60U series 113
- APPENDIX: Grid Support Utility Interactive Inverters 116**
 - Appendix A: Rule 21 116
 - Appendix B: HECO 120
 - Appendix C: Assembly Note 123

Figure

- Figure 2-1: Components of M80/60U 15
- Figure 2-2: Overview of M80/60 series 16
- Figure 2-3: Rating labels of M80U 18
- Figure 2-4: Rating labels of M60U 19
- Figure 2-5: External view and Wiring box layout 21
- Figure 2-6: Wiring box layouts for 120&121(With RSD) models 22
- Figure 2-7: Wiring box layouts for 121(Without RSD)&122 models 23
- Figure 3-1 : Attaching the Hoisting hooks 25
- Figure 3-2: Inverter dimensions 26
- Figure 3-3: How to distinguish new/old models of M80/60U 27
- Figure 3-4: Mounting bracket dimensions for new models 28
- Figure 3-5: Mounting base plate and rear view for new models 29
- Figure 3-6: Required position for at least 8 screws for new models 29
- Figure 3-7: Mounting bracket dimensions for old models 30
- Figure 3-8: Mounting base plate and rear view for old models 31
- Figure 3-9: Required position for at least 8 screws for old models 31
- Figure 3-10: Permitted mounting positions 32
- Figure 3-11: Prohibited mounting positions 32
- Figure 3-12: Wall mount fixed prior to inverter 33
- Figure 3-13: Stress/torque should be prevented when installing the inverter 33
- Figure 3-14: Required mounting clearances 34
- Figure 3-15: Screw locations to secure inverter WB to wall-mounting bracket 34
- Figure 3-16: Installation method of shielding plate 35
- Figure 3-17: Size for AC conductors 39
- Figure 3-18 : Guideline for bi-metal adapter 41
- Figure 3-19: Two optional Location of AC terminals and wiring (120 model) 42
- Figure 3-20: Two optional Location of AC terminals and wiring (120 model) (Continued) 43
- Figure 3-21: Two optional Locations for AC terminal (121 Model With RSD) 44
- Figure 3-22: Two optional Locations for AC terminal (121 Model Without RSD) 45
- Figure 3-23: Location for AC terminal (122 Model) 46
- Figure 3-24: Location and string wiring to DC fuse holders for M80/60U_120 (shown for MPPT 1) 48
- Figure 3-25: Wiring Box layout for M80/60U_120 49
- Figure 3-26: Prohibited fuse location using 20A fuse 49
- Figure 3-27: Size for DC conductors for M80/60U_121 50
- Figure 3-28: DC terminal lug for M80/60U_121 51
- Figure 3-26: Wiring Box layout for M80/60U_121 51
- Figure 3-30: Location for DC terminals for M80/60U_121 52

Figure 3-31: DC Wiring illustration	53
Figure 3-32: Wiring Box layout and Bottom view of inverter chassis showing location of MC4 connectors used to connect array wiring (DC) to M80/60U_122	54
Figure 3-33: Grounding bar locations	55
Figure 3-34: Mounting the DC side ground bar to 121/122 WB	56
Figure 3-35: Communication Module Layout	57
Figure 3-33: Location and access to Communication Module	58
Figure 3-37: Multiinverter connection illustration	60
Figure 3-38: EPO function terminal block	61
Figure 3-39: Rapid shutdown system connection	62
Figure 3-40: Precautions for on-site insulation test	63
Figure 4-1: Front Panel Display	64
Figure 4-2: Grid code, language and ID settings for first start-up	66
Figure 4-3: Home Page screen	67
Figure 4-4: Power Monitoring and String Current Monitoring (_122)	68
Figure 4-5: Energy Log screen	69
Figure 4-6: Event Log screens	69
Figure 4-7: Inverter Information screens	70
Figure 4-8: General Settings screen	70
Figure 4-9: Install settings Display screens	71
Figure 4-10: Inverter ID screen display	72
Figure 4-11: Insulation screen display	72
Figure 4-12: Grid Code screens	72
Figure 4-13: Grid Settings screens	73
Figure 4-14: PID function Display screens	74
Figure 4-15: RCMU screen	74
Figure 4-16: AC Connection	75
Figure 4-17: Anti-Islanding Display screen	75
Figure 4-18: DC AFCI Display screen	76
Figure 4-19: Grid Code Confirm screens	76
Figure 4-20: Active / Reactive power screens	77
Figure 4-21: Power Limit screens	77
Figure 4-22: Power vs Frequency screens	78
Figure 4-23: Power vs Frequency parameter	78
Figure 4-24: P(V) screens	79
Figure 4-25: Constant cosphi screens	79
Figure 4-26: Cosphi (P) screens	80
Figure 4-27: Cosphi (P) curve	80
Figure 4-28: Constant Q screens	81

Figure 4-29: Q(V) screens	81
Figure 4-30: Q(V) parameter	82
Figure 4-31: FRT screens	82
Figure 4-32: FRT Parameter	82
Figure 5-1: Removing and reinstalling the WB cover	83
Figure 5-2: Re-installing process for Wiring Box cover	84
Figure 5-3: AC and DC SPD modules	85
Figure 5-4: Display Indicating AC and DC SPD failure	86
Figure 5-5: Location of SPD modules inside various WB versions	88
Figure 5-6: Remove screws as indicated unplug connectors	89
Figure 5-7: Fuse Board (PWB) and fuse holder locations for M80/60U_120	91
Figure 5-8: Finger-safe fuse holder with blown fuse indicator shown	91
Figure 5-9: Finger-safe fuse holders and fuse access for -120 models	92
Figure 5-10: Fuse holder locations for M80/60U_122	93
Figure 5-11: Accessing the individual fuses for M80/60U_122	93
Figure 5-12: String monitor	94
Figure 5-13: Smart Fans location on Power Module chassis	95
Figure 5-14: Smart Fan locations inside WB chassis	95
Figure 5-15: Power Module Fan tray	96
Figure 5-16: Procedure for Removing WB fan assembly	97
Figure 5-17: Disassembling fan tray from PM chassis (showing one side only)	99
Figure 5-18: Removing the PM air inlet filter	100
Figure 7-1: Thermal Derating curve of M80U	112
Figure 7-2: Thermal Derating curve of M60U	115
Figure B-1: Procedure to confirm Grid Code via LCD – HECO A shown	121
Figure B-2: Details of HECO A: L/H FRT via LCD Settings menu	121
Figure B-3: Details of HECO A & B: L/H VRT via LCD Settings menu	122

Table

Table 2-1: Packing list of M80/60U	15
Table 2-2: Rating label explanation of M80/60U	20
Table 2-3: Wiring box layout description	22/23
Table 3-1: RS-485 Terminal block wiring	59
Table 3-2: Vcc and Bus Termination switch settings	60
Table 3-3: Definition of digital input & EPO function	61
Table 4-1: LED indicator	65
Table 4-2: Programming keys and actions	65
Table 4-3: Inverter Functions	67
Table 4-4: Controls Access Levels	71
Table 4-5: Dry Contact Trigger Options	74
Table 5-1: SPD Specifications	85
Table 5-2: Combiner Fuse Specification	90
Table 6-1A: Error Codes and Messages	103
Table 6-1B: Error Codes and Messages	104
Table 6-2A: Warning Codes and Messages	104
Table 6-3A: Fault Codes & Messages	105
Table 6-3B: Fault Codes & Messages	106
Table 6-3C: Fault Codes & Messages	107
Table 6-3D: Fault Codes & Messages	108
Table 7-1A: Specifications for M80U	110
Table 7-1B: Specifications for M80U	111
Table 7-2A: Specifications for M60U	113
Table 7-2B: Specifications for M60U	114
Appendix A-1: Low and High Voltage Ride-Through Set-points and Timing per Table SA9.1D	116
Appendix A-2: Low and High Frequency Ride-Through Set-points and Timing per Table SA10.1	116
Appendix A-3: CA R21 Settings – Normal Ramp Rate (RR) & Soft-Start Ramp Rate (SS)	117
Appendix A-4: CA R21 Settings – Soft-start ramp rate test	117
Appendix A-5: CA R21 Settings – Specified Power Factor	117
Appendix A-6: CA R21 Settings – Volt/VAr Mode (Q(V))	118
Appendix A-7: CA R21 Settings – Frequency-Watt (FW)	118
Appendix A-8: CA R21 Settings – Volt-Watt (VW)	119
Appendix B-1: Full Frequency Ride-Through Settings for O’ahu, Hawai’i Island, and Maui (HECO A)	120
Appendix B-2: Full Frequency Ride-Through Settings for Moloka’i and Lana’i (HECO B)	120
Appendix B-3: Full Voltage Ride-through Settings for O’ahu, Hawai’i Island, Maui, Moloka’i, and Lana’i	120
Appendix C-1: Assembly Note for All model	123
Appendix C-2: Assembly Note for 120 model	124
Appendix C-3: Assembly Note for 121 model (With RSD)	125
Appendix C-4: Assembly Note for 121 model (Without RSD)	126
Appendix C-5: Assembly Note for 122 model	127

1 Safety

1.1 Information of the Inverter

1.1.1 Legal Provisions

Copyright – DELTA ELECTRONICS, INC. - All rights reserved.

This manual accompanies our product for use by the end users. The technical instructions and illustrations contained in this manual are to be treated as confidential and no part may be reproduced without the prior written permission of DELTA ELECTRONICS, INC. Service engineers and end users may not divulge the information contained herein or use this manual for purpose other than those strictly connected with correct use of the product. All information and specifications are subject to change without notice.

DELTA ELECTRONICS, INC. shall have no obligation to either personal injury and property damage claims hereinafter with respect to any actions -- (a) the product has been installed and/or repaired improperly; (b) the product has been misused without following the instructions on this user manual; (c) the product has failed due to incorrect unpacking.

1.1.2 Target Group

This - manual – is prepared for use by a well-trained technician for installing, commissioning, operation, and maintenance. The technician must have the following basic and advanced skills:

- Knowledge of the fundamentals of electricity, wiring, electrical components and electrical schematic symbols.
- Knowledge of how a solar inverter works and is operated.
- Training in the installation and commissioning of electrical devices and installations.
- Training in how to deal with the dangers and risks associated with installing and using electrical devices and installations.
- Compliance with this manual and all safety information.

1.2 General Safety

IMPORTANT SAFETY INSTRUCTIONS : SAVE THESE INSTRUCTIONS !



- Please read these instructions carefully and save them for later use.

To prevent personal injury and/or property damage, and also to ensure long term operation of the solar inverter, it is imperative this section be read carefully and all the safety instructions understood before using this inverter.

This user manual provides important instructions for Delta grid-tie transformerless solar inverter. The product is designed, tested, verified, and certified according to international safety requirements, certifications, and standards but precautions must be observed when installing and operating the product.

The inverter installation must be performed by an authorized electrician in accordance with the the National Electrical Code® ANSI/NFPA 70 or the Canadian Electrical Code® CSA C22.1 and/or other prevailing local codes, as well as OSHA requirements. This product is suitable for both indoor and outdoor use.

ATTENTION : NO GALVANIC ISOLATION



- The design of this inverter is transformerless. There is no isolation transformer between the AC and DC sides, i.e., the product does not require galvanic isolation. In order to function properly, any PV array connected must have its PV circuits isolated from ground, i.e., do not bond either side of the array to ground! If a grounded PV array is connected to the inverter, the error message INSULATION (E34) will appear on the display.
- It is prohibited to reference the L1, L2, or L3 terminal to ground; to do so will damage the inverter and void the product warranty.

1.2.1 Condition of Use

- The M80/60U is a transformerless solar inverter with dual independent MPP tracking inputs, each of which converts the variable direct current generated by the solar array into a utility frequency grid-compliant balanced three-phase AC current and feeds it into the utility grid.
- The Photovoltaic modules used must be compatible with the inverter. PV modules with a high parasitic capacitance to ground may only be utilized if the capacitive coupling does not exceed 8 μ F. (for each MPPT channel)
- The inverter must only be operated in countries for which it is approved by Delta and the grid operator.

1.2.2 Symbols

This section describes the definition of the symbols in this manual. In order to prevent both personal injury and property damage, and to ensure long-term operation of the product, please read this section carefully and follow all the safety instructions while you use the product.

DANGER!



- This warning indicates an immediate hazard which will lead to death or serious injury.

WARNING !



- This warning indicates a hazardous condition which may lead to death or serious injury.

CAUTION !



- This warning indicates a hazardous condition which may lead to minor injury.

ATTENTION



- This warning indicates a condition of potential damage to property and/or the environment.

INFORMATION

- An exclamation mark enclosed in a double circle indicates additional important information is contained in the following section and the user should follow the instructions to prevent any hazards.

DANGER : ELECTRICAL HARZARD!!

- This warning indicates an immediate electrical hazard that unheeded can lead to death or serious injury.

CAUTION : HOT SURFACES, DO NOT TOUCH!

- This warning indicates a potential burn hazard.
- Use care when touching surfaces when operating the product.
- Do not perform any task until the product cools down sufficiently.



- This icon indicates that a prescribed time delay must elapse before engaging in an indicated action.
- Patientez le délai requis avant d'entreprendre l'action indiquée.



- This symbol indicates the location of an equipment grounding conductor (EGC) terminal.

2 Introduction

The M80/60U transformerless 3Ø PV inverters are designed to enable the highest levels of efficiency and provide longest operating life by use of state-of-the-art high frequency and low EMI switchmode technology.

They meet the design requirements of UL1741/SA, IEEE1547, IEEE1547.1, IEEE1547.A and OSHA, and is suitable for indoor or outdoor use.



- This product utilizes a transformerless design, and is not provisioned with an isolation transformer, and therefore has no galvanic isolation between the DC and AC sides.

PV array circuits connected must be floating with respect to ground, i.e., must not be referenced (bonded) to ground.

If grounded PV arrays are connected to the inverter, the inverter will not connect to the grid and the error message INSULATION (E34) will appear on the display.

- It is prohibited to connect terminals L1, L2, or L3 to ground.

The inverter installation must be performed by an authorized electrician in accordance with the the National Electrical Code® ANSI/NFPA 70 or the Canadian Electrical Code® CSA C22.1 and/or other prevailing local codes, as well as OSHA requirements.

2.1 Valid Model

The user manual is valid for the following device types:

- M80U_120
- M80U_121
- M80U_122
- M60U_120
- M60U_121
- M60U_122

For 121 models there are two versions, MxxU_121 with RSD (Rapid Shutdown Device) and MxxU_121 without RSD, please refer **Figure 2-5** for details.

This user manual must be followed during installation, operation, and maintenance.

The M80/60 Series each have three models as shown in **Figure 2-2**. Delta reserves the right to make modifications to the content and technical data in this user manual without prior notice.

2.2 Product Overview

The components of M80/60U is shown as **Figure 2-1**.

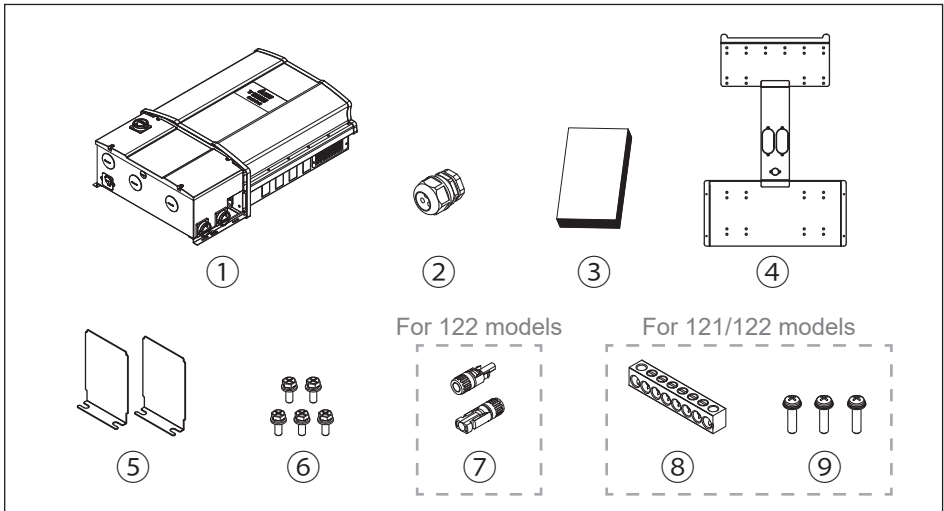

Figure 2-1: Components of M80/60U

M80U / M60U			
	Object	Qty	Description
1	Delta Solar Inverter	1 pc	Solar inverter
2	Wiring Gland	1 pc	For communication port wiring
3	User Manual	1 pc	Important instructions for solar inverter Safety instructions should be followed during installation and maintenance
4	Mounting Bracket	1 pc	Wall mounting bracket (Material: Aluminum/Thickness: 3mm)
5	Shielding plate	1 pair	Shielding plate for filter (use is optional)
6	Screw	5 pcs	To secure inverter to mounting bracket (Stainless/M6/12mm)
7	MC4 connector	18 pairs	String inputs for M80/60U_122 models
8	Al Alloy Busbar	1 pc	DC side PE/EGC Ground bar (121/122 Models)
9	Screw	3 pcs	Ground bar mounting screws (121/122 Models) (Stainless/M5/21mm)

Table 2-1: Packing list of M80/60U

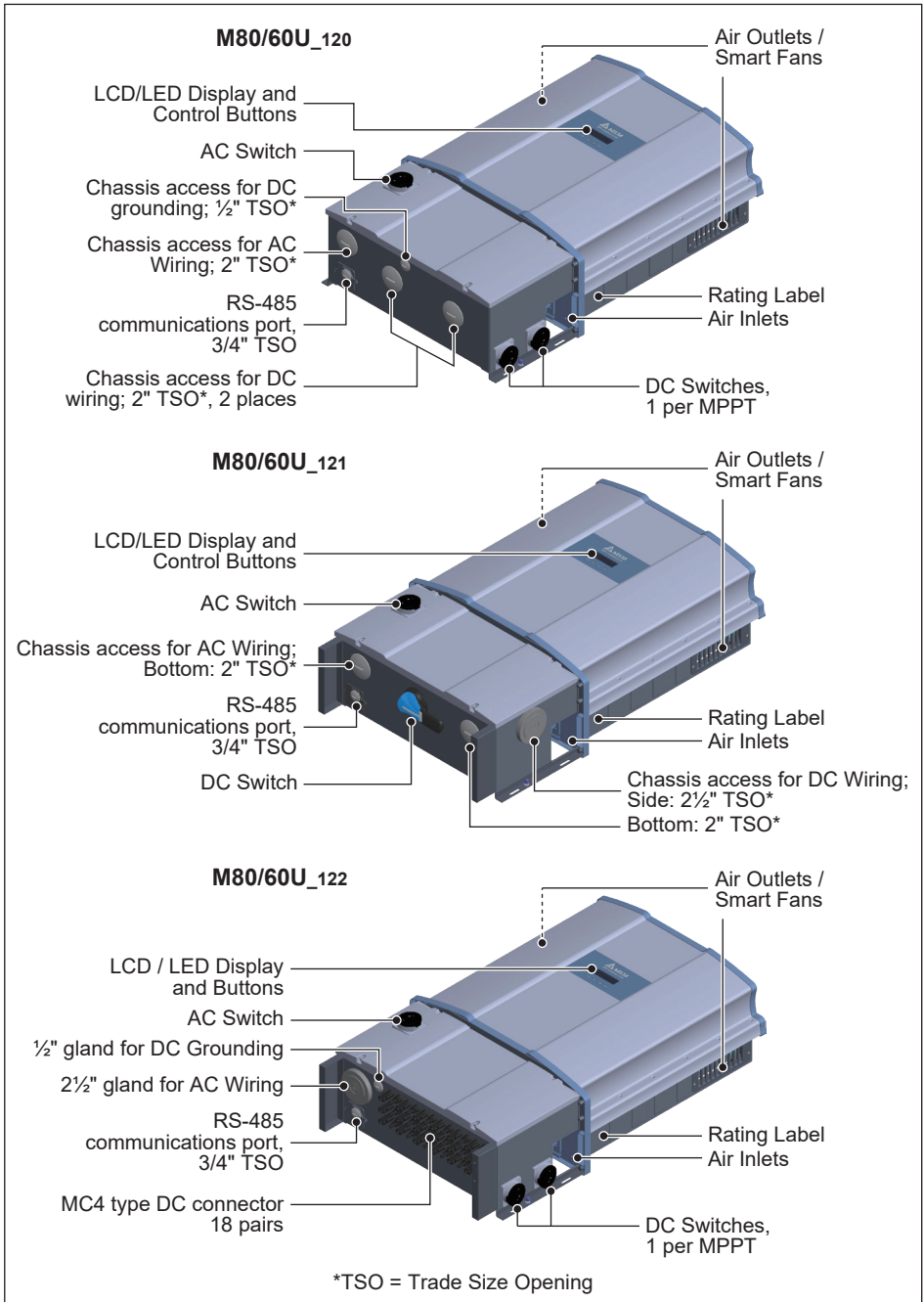
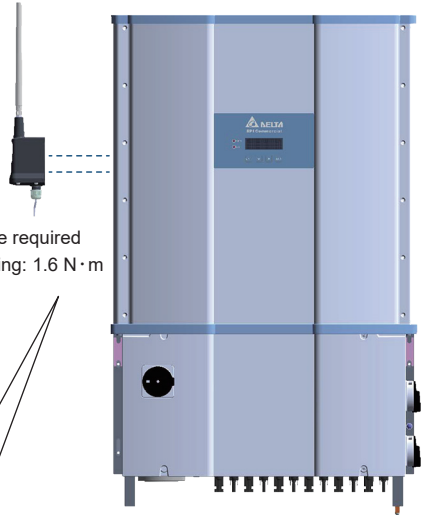
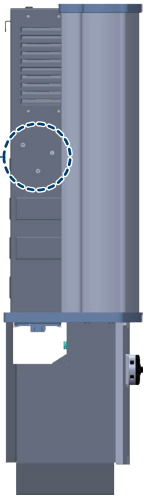

Figure 2-2: Overview of M80/60 series

SUB_1G
(optional)

* Screw torque required
for assembling: $1.6 \text{ N} \cdot \text{m}$



Vertical mounting

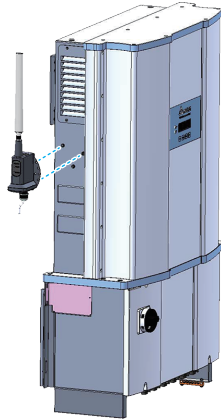

Horizontal mounting

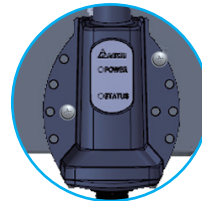
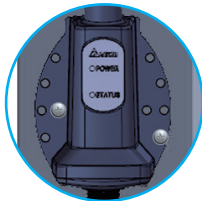
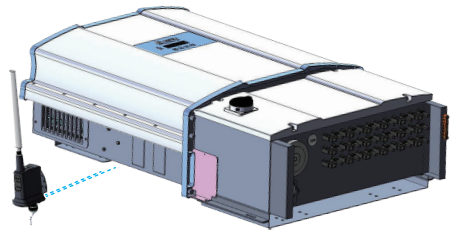

SUB_1G support all kind of tilt installation angle ($0 \sim 90^\circ$),
make sure the antenna is vertical to ground.

Figure 2-3.2-4, below, shows the certification and rating labels of M80/60U, and **Table 2-2**, defines the symbol markings on these labels.

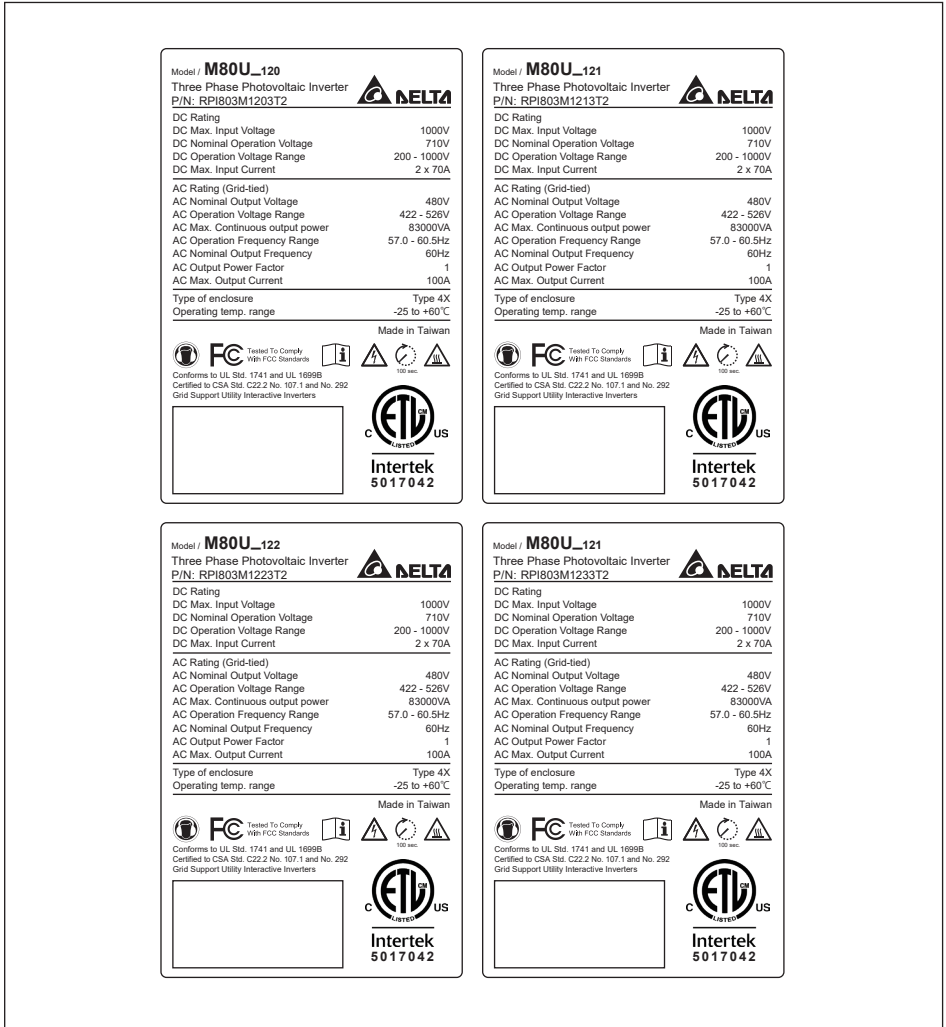



Figure 2-3: Rating labels of M80U

Model / **M60U_120**
 Three Phase Photovoltaic Inverter
 P/N: RP1603M1203T2 



DC Rating	
DC Max. Input Voltage	1000V
DC Nominal Operation Voltage	710V
DC Operation Voltage Range	200 - 1000V
DC Max. Input Current	2 x 60A



AC Rating (Grid-tied)	
AC Nominal Output Voltage	480V
AC Operation Voltage Range	422 - 526V
AC Max. Continuous output power	66000VA
AC Operation Frequency Range	57.0 - 60.5Hz
AC Nominal Output Frequency	60Hz
AC Output Power Factor	1
AC Max. Output Current	80A

Type of enclosure Type 4X
 Operating temp. range -25 to +60°C

Made in Taiwan

 Tested To Comply With FCC Standards
 Conforms to UL Std. 1741 and UL 1699B
 Certified to CSA Std. C22.2 No. 107.1 and No. 292
 Grid Support Utility Interactive Inverters

Intertek
5017042

Model / **M60U_121**
 Three Phase Photovoltaic Inverter
 P/N: RP1603M1213T2 



DC Rating	
DC Max. Input Voltage	1000V
DC Nominal Operation Voltage	710V
DC Operation Voltage Range	200 - 1000V
DC Max. Input Current	2 x 60A



AC Rating (Grid-tied)	
AC Nominal Output Voltage	480V
AC Operation Voltage Range	422 - 526V
AC Max. Continuous output power	66000VA
AC Operation Frequency Range	57.0 - 60.5Hz
AC Nominal Output Frequency	60Hz
AC Output Power Factor	1
AC Max. Output Current	80A

Type of enclosure Type 4X
 Operating temp. range -25 to +60°C

Made in Taiwan

 Tested To Comply With FCC Standards
 Conforms to UL Std. 1741 and UL 1699B
 Certified to CSA Std. C22.2 No. 107.1 and No. 292
 Grid Support Utility Interactive Inverters

Intertek
5017042

Model / **M60U_122**
 Three Phase Photovoltaic Inverter
 P/N: RP1603M1223T2 



DC Rating	
DC Max. Input Voltage	1000V
DC Nominal Operation Voltage	710V
DC Operation Voltage Range	200 - 1000V
DC Max. Input Current	2 x 60A



AC Rating (Grid-tied)	
AC Nominal Output Voltage	480V
AC Operation Voltage Range	422 - 526V
AC Max. Continuous output power	66000VA
AC Operation Frequency Range	57.0 - 60.5Hz
AC Nominal Output Frequency	60Hz
AC Output Power Factor	1
AC Max. Output Current	80A

Type of enclosure Type 4X
 Operating temp. range -25 to +60°C

Made in Taiwan

 Tested To Comply With FCC Standards
 Conforms to UL Std. 1741 and UL 1699B
 Certified to CSA Std. C22.2 No. 107.1 and No. 292
 Grid Support Utility Interactive Inverters

Intertek
5017042

Model / **M60U_121**
 Three Phase Photovoltaic Inverter
 P/N: RP1603M1233T2 



DC Rating	
DC Max. Input Voltage	1000V
DC Nominal Operation Voltage	710V
DC Operation Voltage Range	200 - 1000V
DC Max. Input Current	2 x 60A



AC Rating (Grid-tied)	
AC Nominal Output Voltage	480V
AC Operation Voltage Range	422 - 526V
AC Max. Continuous output power	66000VA
AC Operation Frequency Range	57.0 - 60.5Hz
AC Nominal Output Frequency	60Hz
AC Output Power Factor	1
AC Max. Output Current	80A

Type of enclosure Type 4X
 Operating temp. range -25 to +60°C

Made in Taiwan

 Tested To Comply With FCC Standards
 Conforms to UL Std. 1741 and UL 1699B
 Certified to CSA Std. C22.2 No. 107.1 and No. 292
 Grid Support Utility Interactive Inverters

Intertek
5017042

Figure 2-4: Rating labels of M60U







Symbol	Definition
	FCC designation
	Please read the user manual for further information
	Danger : Electrical Hazard
	This icon indicates that a prescribed time delay must elapse before engaging in an indicated action. Electrical hazard might exist before this duration.
	Warning of the hot surface of the inverter
	ETL Listed Mark approved by Intertek Lab Certified as Grid Support Utility Interactive Inverter
	Use noise protection PPE

Table 2-2: Rating label explanation of M80/60U

In the following pages, **Figures 2-4** illustrate the general layout of the M80U/M60U chassis and wiring box. **Figure 2-5** and **Table 2-3**, provides a detailed description of each wiring box option.

The Wiring Box area includes terminals for connection of the inverter input (DC) wiring, output (AC) wiring, RS-485 communication and other signal wiring, as well as DC & AC surge protection devices (SPD), DC switches, and fuse holders for some models.

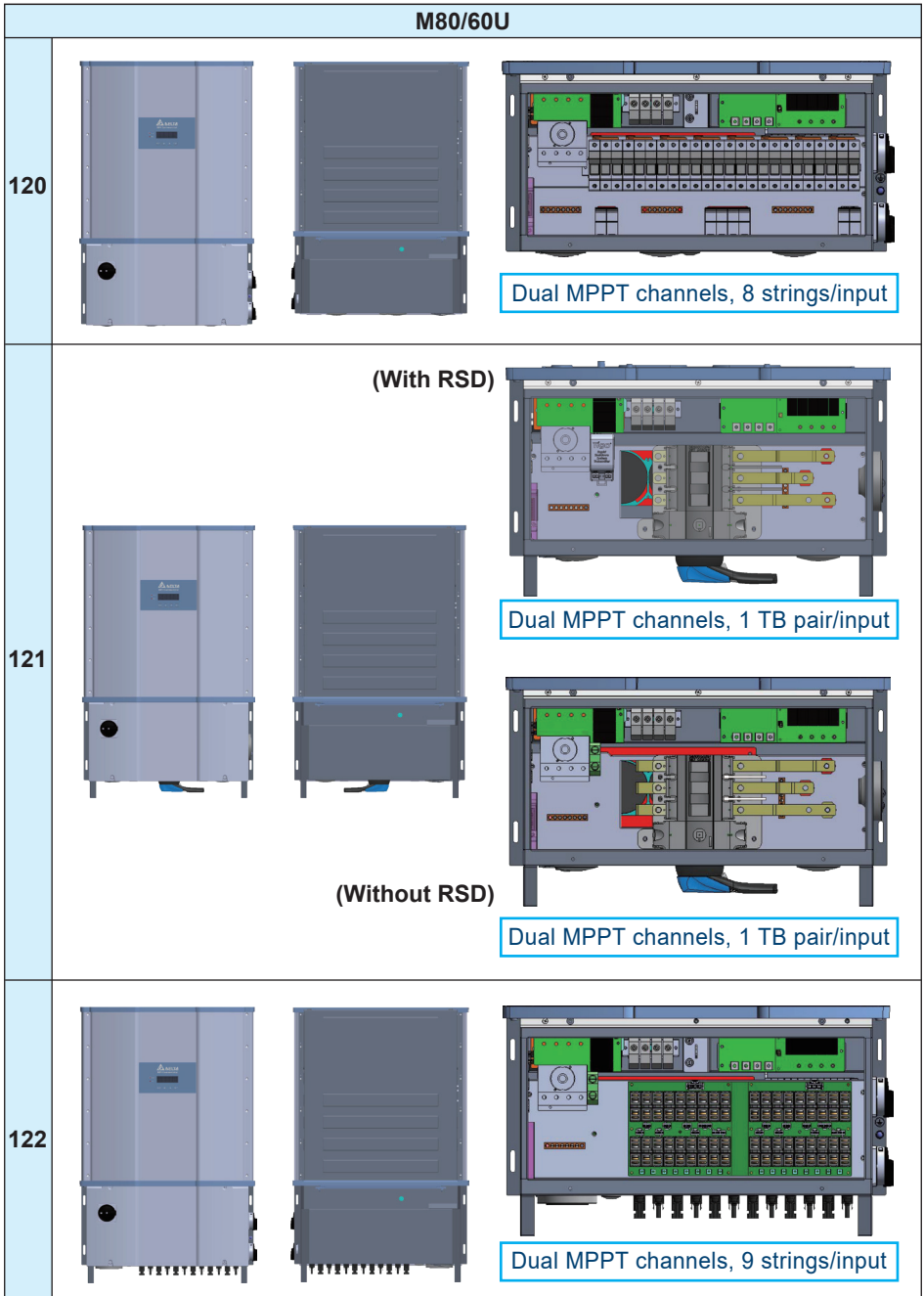
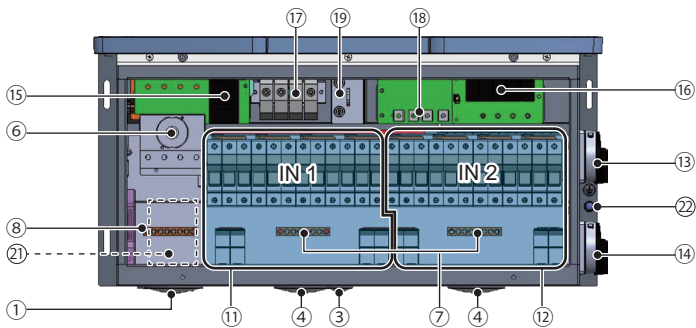

Figure 2-5: External view and Wiring box layout

-120 Model WB



-121 Model WB (With RSD)

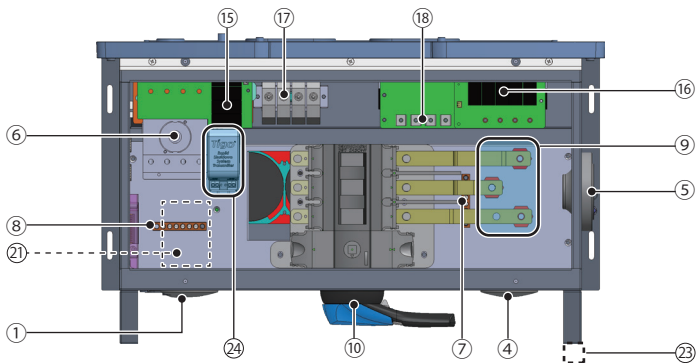
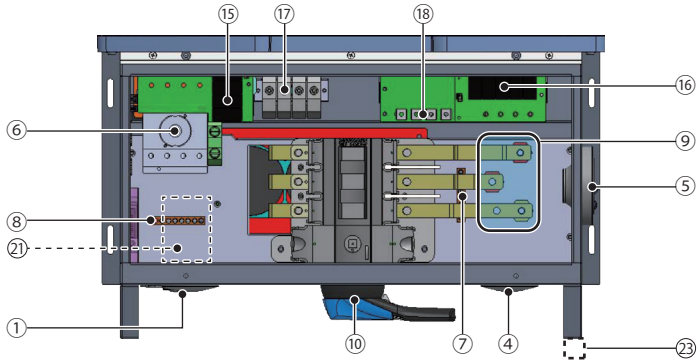
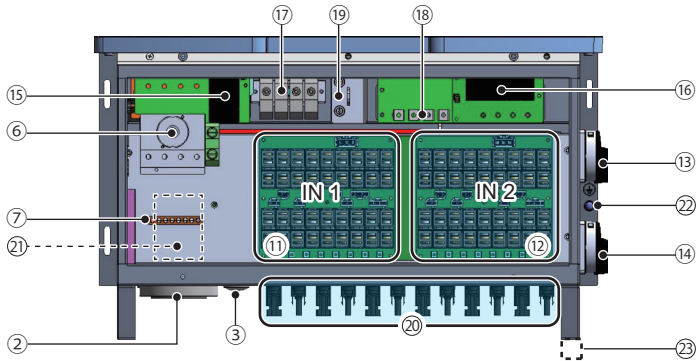

Figure 2-6: Wiring box layouts for 120&121(With RSD) models

NO.	Component	NO.	Component	NO.	Component
1	2" cable opening for AC	9	DC terminal	17	Internal AC terminal
2	2½" cable opening for AC	10	DC switch	18	Internal DC terminal
3	½" cable opening for DC grounding	11	Fuse holder type DC IN1	19	Wiring box fan
4	2" cable opening for DC	12	Fuse holder type DC IN2	20	MC4 connectors (18 pairs)
5	2½" cable opening for DC	13	DC switch for IN1	21	Communication port
6	AC switch	14	DC switch for IN2	22	Grounding (M6 threaded stud)
7	DC grounding bar	15	Type II AC SPD	23	External ground bar location
8	AC grounding bar	16	Type II DC SPD	24	Rapid shutdown transmitter

Table 2-3: Wiring box layout description

-121 Model WB (Without RSD)**-122 Model WB****Figure 2-7: Wiring box layouts for 121(Without RSD)&122 models**

NO.	Component	NO.	Component	NO.	Component
1	2" cable opening for AC	9	DC terminal	17	Internal AC terminal
2	2½" cable opening for AC	10	DC switch	18	Internal DC terminal
3	½" cable opening for DC grounding	11	Fuse holder type DC IN1	19	Wiring box fan
4	2" cable opening for DC	12	Fuse holder type DC IN2	20	MC4 connectors (18 pairs)
5	2½" cable opening for DC	13	DC switch for IN1	21	Communication port
6	AC switch	14	DC switch for IN2	22	Grounding (M6 threaded stud)
7	DC grounding bar	15	Type II AC SPD	23	External ground bar location
8	AC grounding bar	16	Type II DC SPD		

Table 2-3: Wiring box layout description

3 Installation

CAUTION !



- In some locations, mounting the inverter in direct sunlight may cause the inverter to enter a thermal derating mode. To eliminate this concern, a shade structure over the inverter chassis may be necessary.

WARNING !



- Do not install the unit near or on flammable surfaces.
- Inverter must be mounted securely to a solid / smooth surface.

The chapter contains instructions for

- (1) Mechanical installation
- (2) Electrical Installation
- (3) Communication setup

Figure 3-1 shows the hoisting hook instruction.

Figure 3-2 provides the mechanical dimensions of the inverter.

3.1 Mechanical Installation

This unit is designed to be wall-mounted per **Section 3.1.1** or Tilt Mounted per **Section 3.1.2**.

3.1.1 Vertical wall mount

Refer to **Figures 3-3** through **Figures 3-15**.

1. Ensure the surface to which the unit is to be mounted is sufficiently strong enough to carry the weight.
2. Orient the wall bracket (**Figure 3-4**, **Figure 3-5** or **Figure 3-7**, **Figure 3-8**) horizontally (perpendicular to the floor), with the large plate at the bottom, and mark required mounting hole locations per **Figure 3-6** or **Figure 3-9**.
3. Secure the mounting bracket on the wall with at least 8 5/16" (M8) screws.
4. Hang the inverter on the wall mounting bracket.
5. Secure the inverter by inserting and tightening four screws (item 6, **Figure 2-1**) as shown in **Figure 3-15**.

3.1.2 Horizontal or Tilt mount

1. Refer to **Figure 3-10**. Ensure the mounting stand meets the mounting dimensions shown, with the large plate at the lowest end of the stand. Ensure the stand is sufficiently strong enough to carry the inverter weight.
2. For vertical installation, if the inverter is exposed to sunlight (without shading), **a name plate cover must be installed** to extend the lifetime of LCD display. Please refer to **Figure 3-10** for an example of name plate cover.
3. For tilt installation, **a name plate cover must be installed** to add protection against harsh environmental conditions such as: direct sunlight, hail, snow and pecking from birds. Please refer to **Figure 3-10** for an example of name plate cover.
4. Orient the mounting bracket (**Figure 3-4, Figure 3-5 or Figure 3-7, Figure 3-8**) squarely on the inverter stand, and ensure cross-supports are located in line with the mounting screws locations shown in **Figure 3-6 or Figure 3-9** (horizontal case) such that they can all be secured.
Mark required mounting hole locations per **Figure 3-6 or Figure 3-9**.
5. Secure the mounting bracket to the stand with at least 8 x 5/16" (M8) screws.
6. Hang the inverter on the mounting bracket.
7. Secure the inverter by inserting and tightening four screws as shown in **Figure 3-15**.

CAUTION !



- The mounting bracket shipped with the unit is specially designed and is the only certified mounting device for mounting the inverter.
- Use a minimum of eight 5/16in (M8) screws to affix the mounting bracket to mounting surface. See **Figure 3-6 or Figure 3-9**.

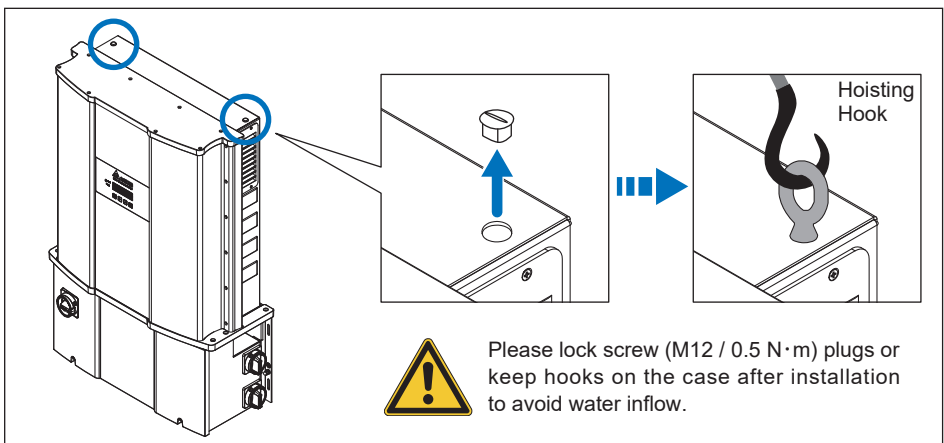

Figure 3-1 : Attaching the Hoisting hooks

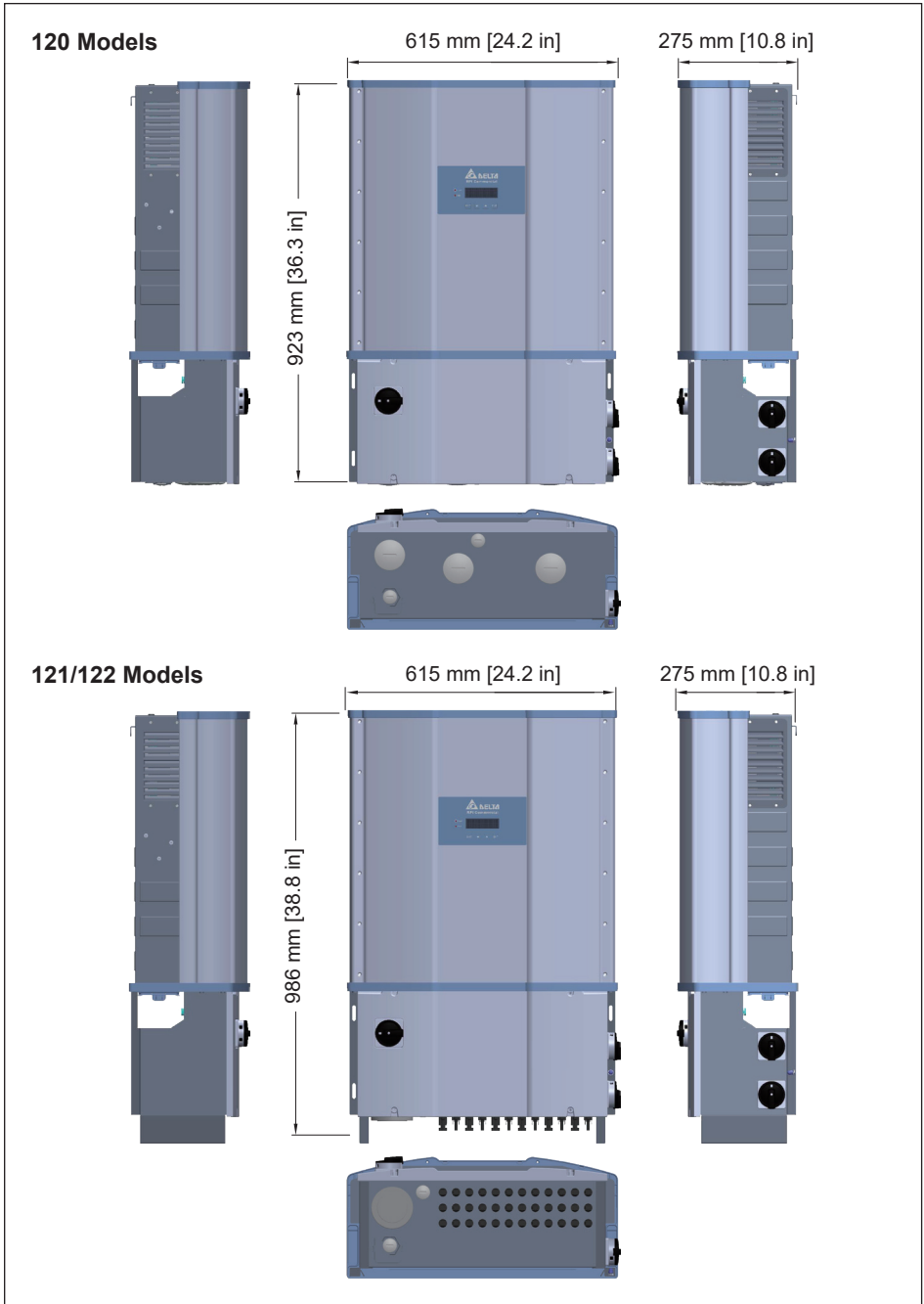

Figure 3-2: Inverter dimensions

3.1.3 Mounting Bracket

This section introduces how to install new/old models of M80/60U with new version of mounting bracket.

New models of M80/60U with new version of mounting bracket, please refer to **section 3.1.3.1**

Old models of M80/60U with new version of mounting bracket, please refer to **section 3.1.3.2**

Figure 3-3 shows how to distinguish new/old models of M80/60U.

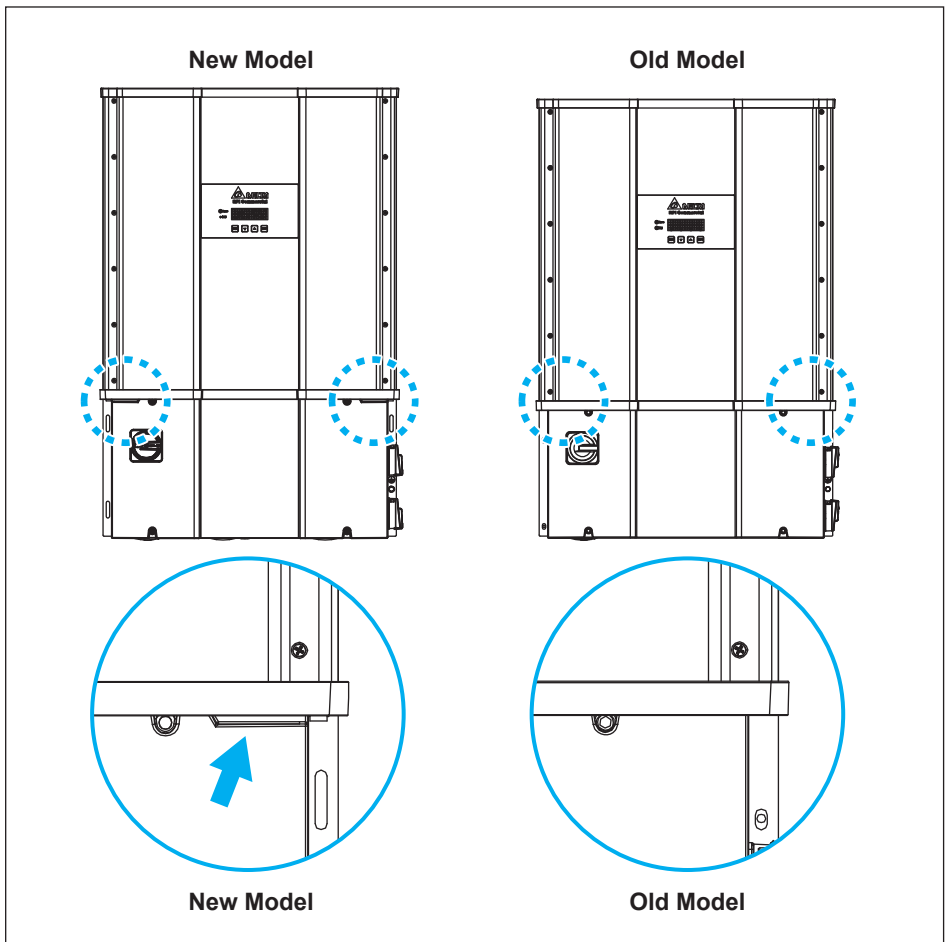

Figure 3-3: How to distinguish new/old models of M80/60U

3.1.3.1 New Models With New Version of Mounting Bracket

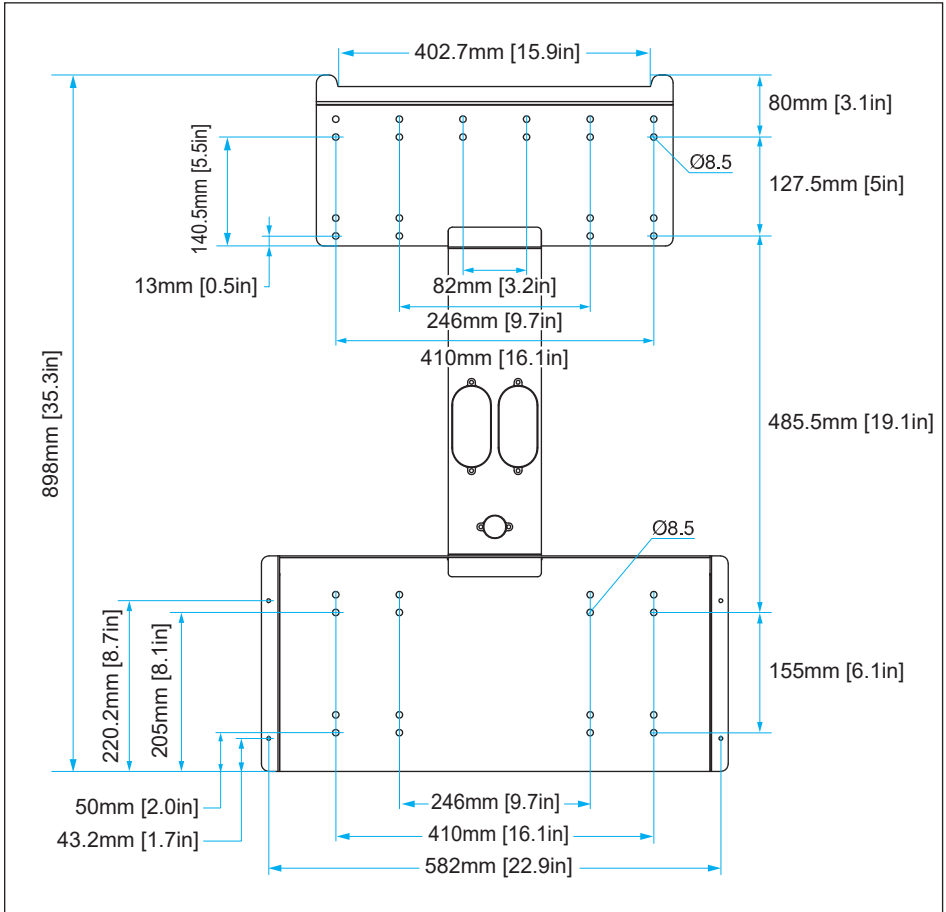

Figure 3-4: Mounting bracket dimensions for new models

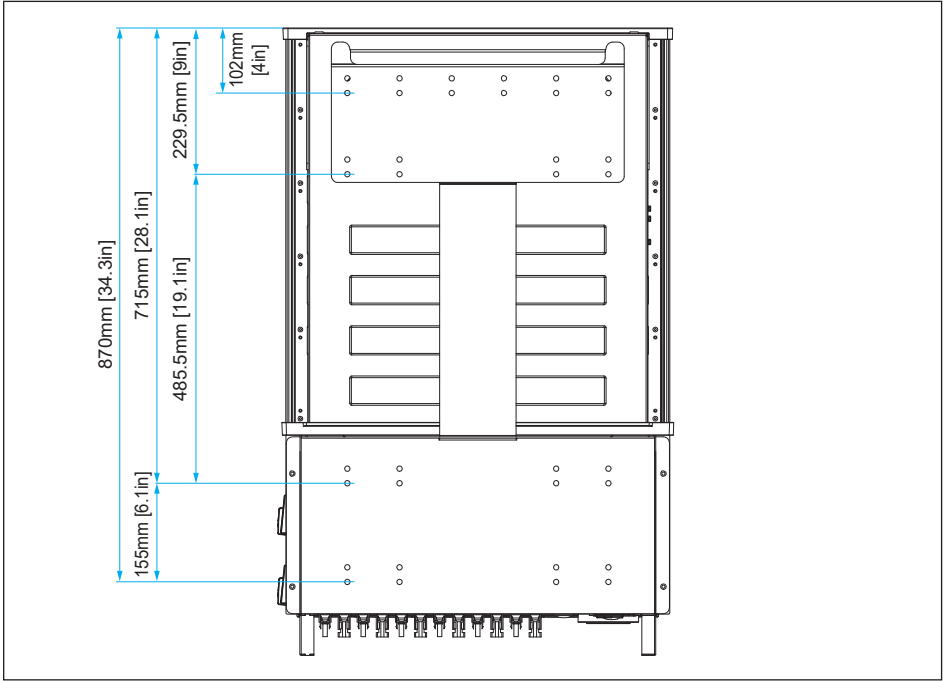

Figure 3-5: Mounting base plate and rear view for new models

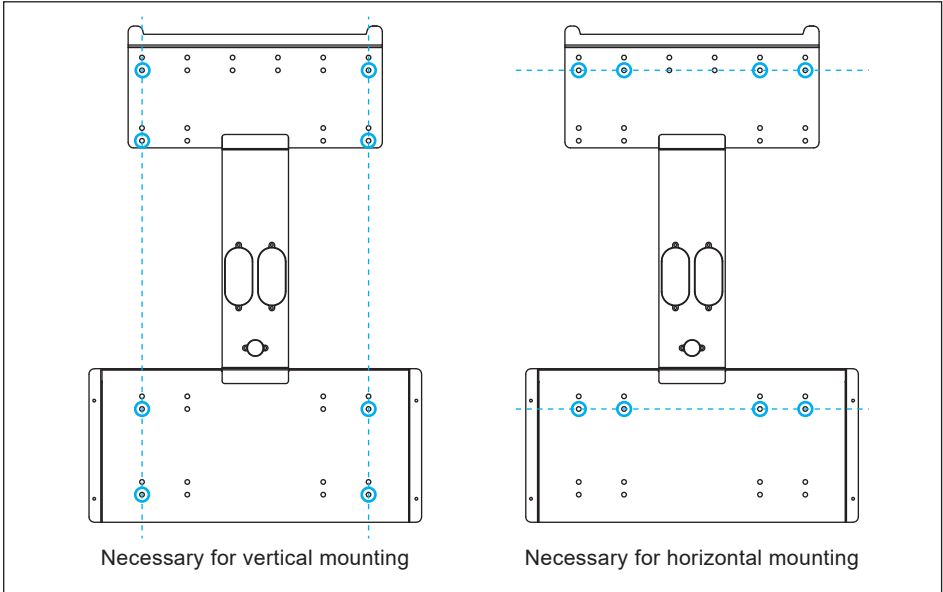

Figure 3-6: Required position for at least 8 screws for new models

3.1.3.2 Old Models With New Version of Mounting Bracket

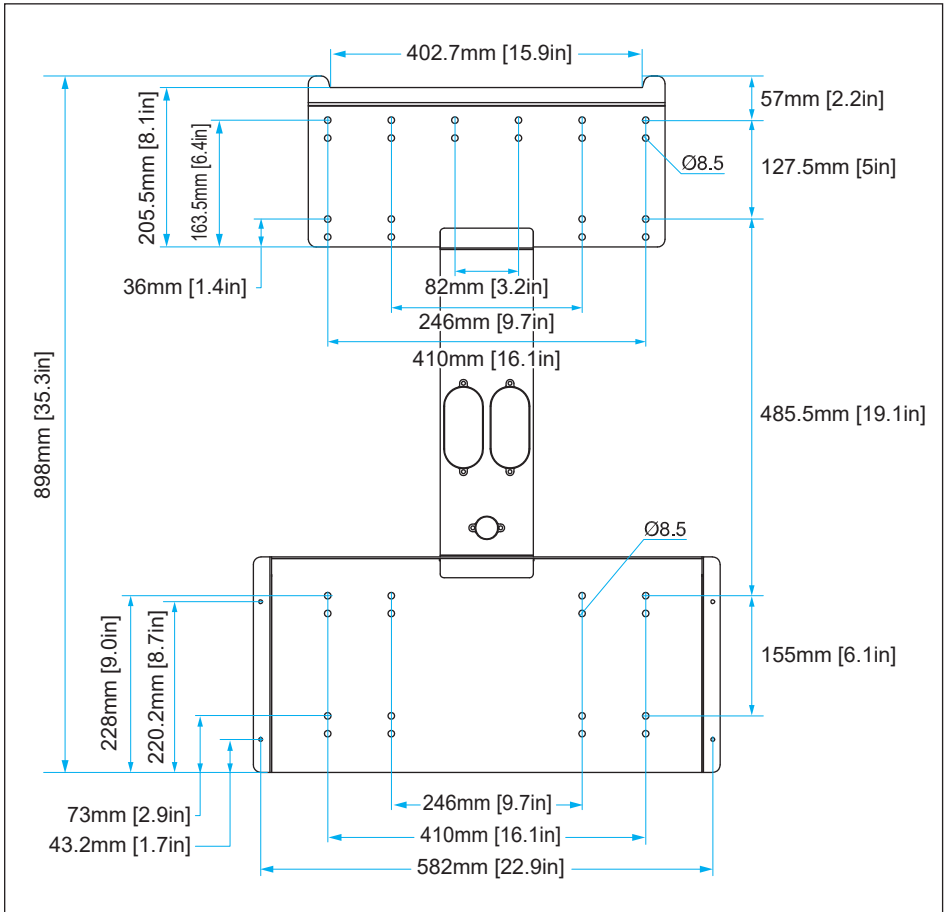

Figure 3-7: Mounting bracket dimensions for old models

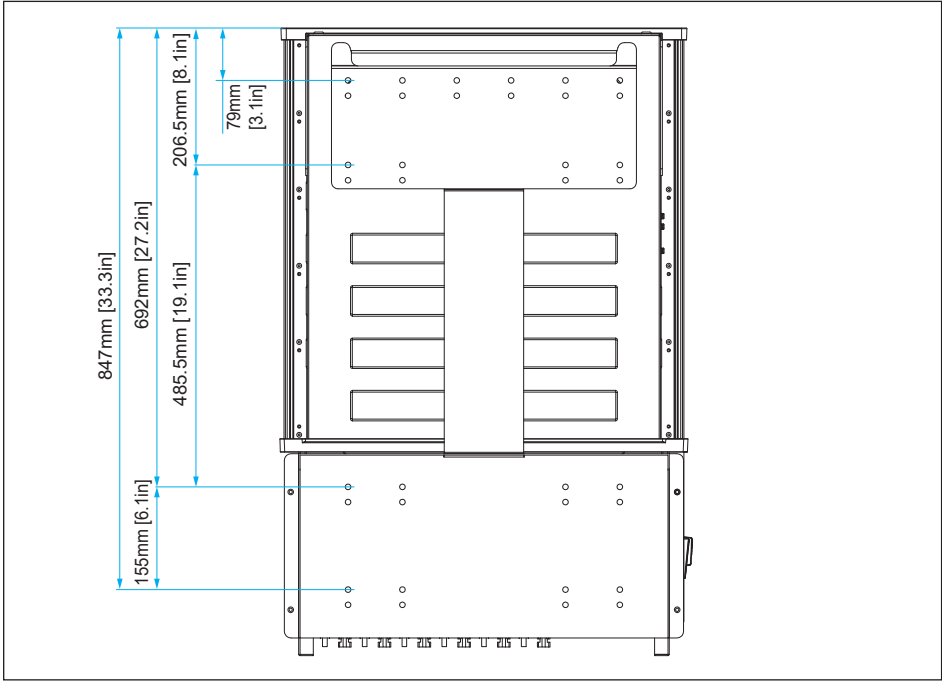

Figure 3-8: Mounting base plate and rear view for old models

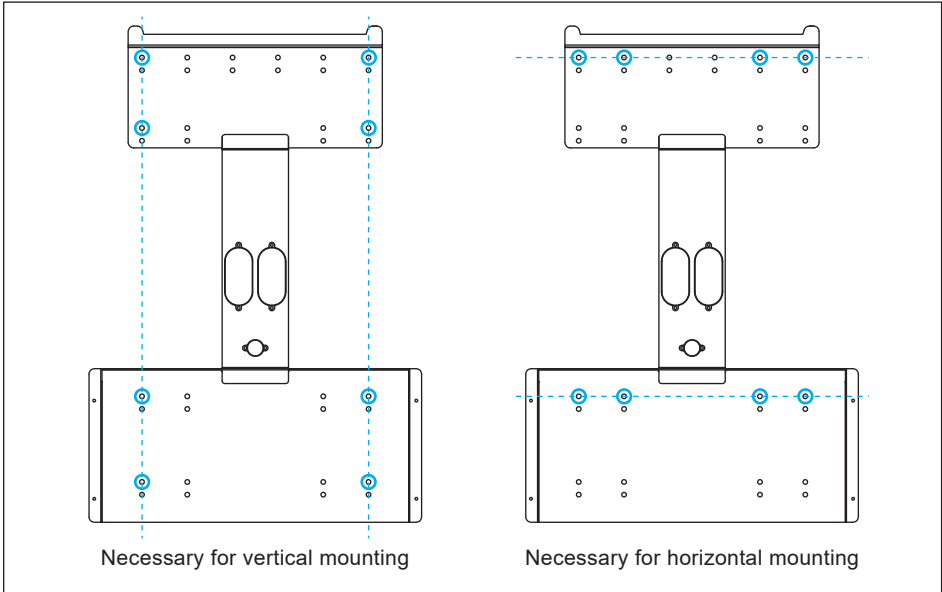

Figure 3-9: Required position for at least 8 screws for old models

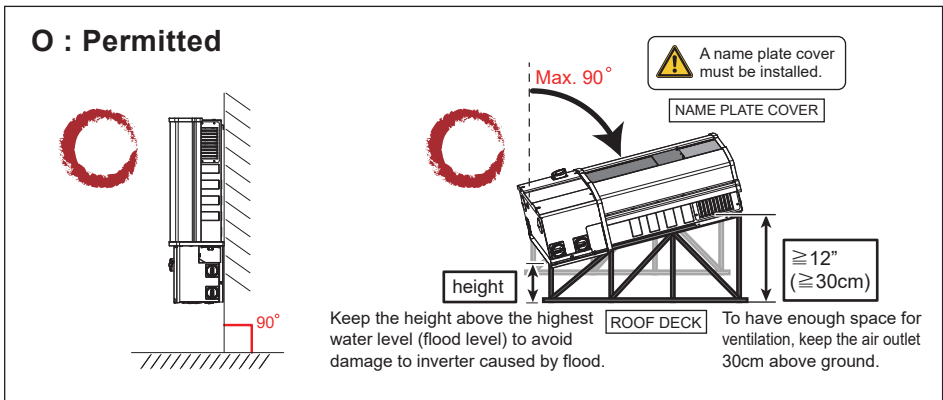

Figure 3-10: Permitted mounting positions

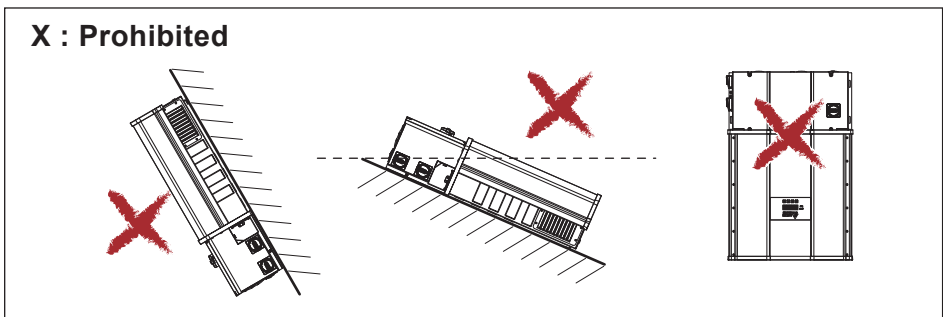
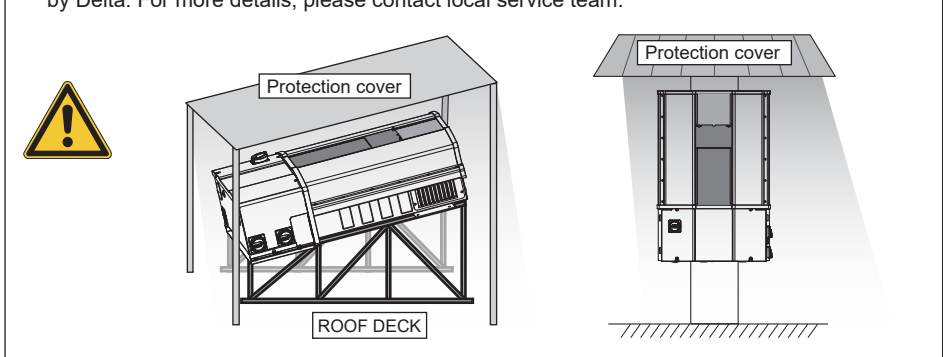

Figure 3-11: Prohibited mounting positions

CAUTION !

- Name plate cover is required for all types of installation.
- To avoid malfunction of inverter caused by extreme weather (ex: snow, hail...etc) or non-proper installation/maintenance, an additional protection cover is strongly recommended to be installed by Delta. For more details, please contact local service team.



**CAUTION !**

1. Install the wall mount bracket to the rack system prior to installing the inverter. Do not allow bending of the bracket. See **Figure 3-12**.
2. When installing the inverter on the rack system, use care not to apply excessive stress/torque as shown in **Figure 3-13**. It's known that for most tilt installations, a rigid conduit body (e.g./ "LB") will be applied to the AC side. Installer must exercise care when installing, as overstressing the chassis may open a path for water intrusion through the contact surface between the inverter module and the wiring box.

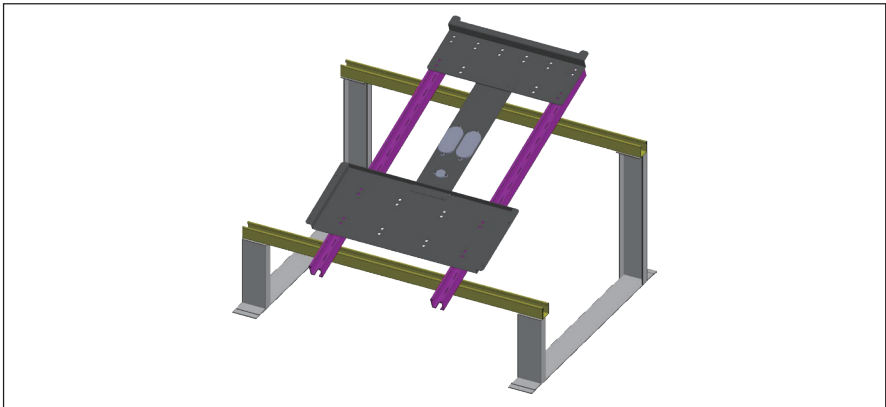

Figure 3-12: Wall mount fixed prior to inverter

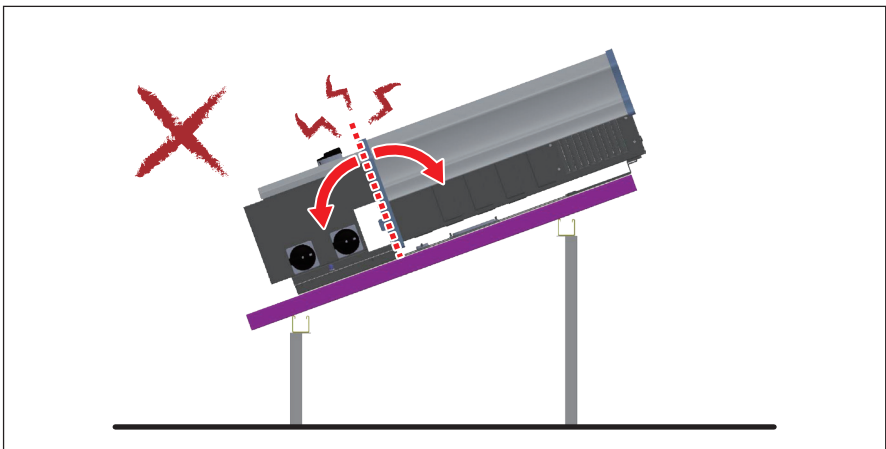

Figure 3-13: Stress/torque should be prevented when installing the inverter

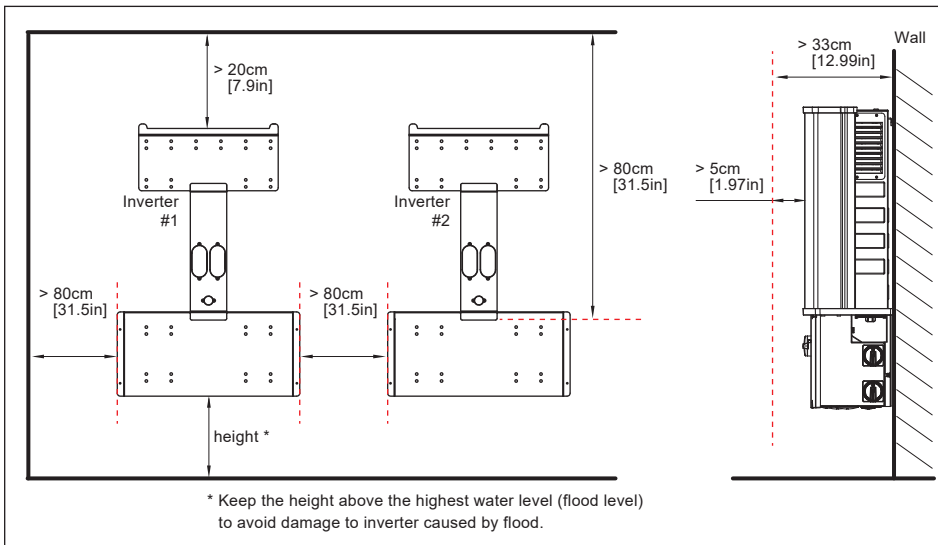

Figure 3-14: Required mounting clearances

CAUTION !



- Failure to comply with above mounting instructions including permitted orientations and designated clearances may result in derated power output and may void the warranty. To avoid these issues follow the instructions above!

After installing the unit on the bracket, secure the wiring box to the bracket with four screws per **Figure 3-15**. Tighten the screws to a torque of 40 lbf-in (4.5 N·m)

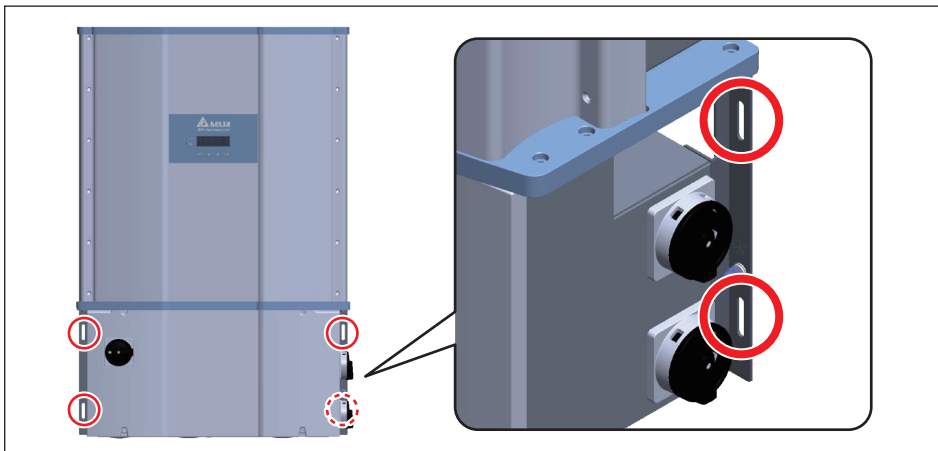

Figure 3-15: Screw locations to secure inverter WB to wall-mounting bracket

3.1.4 Accessories

Included with the inverter hardware are two sheet metal side shields, which can be used to cover the open ends of the air inlet channel as shown in **Figure 3-16**, and are intended to minimize nesting in the air channel by wildlife. Two shields and associated screws are included.

Use of the shields does not significantly reduce airflow into the inlet filter, as the rear side of the air channel is open, and thermal testing with the shields in place has verified there is no associated operational degradation or derating of the inverter due to their use as long as the rear access remains open.

To use the shielding plate, please refer to the installation method in **Figure 3-16**. Tighten the screws to a torque value of 40 lbf-in (4.5 N·m)

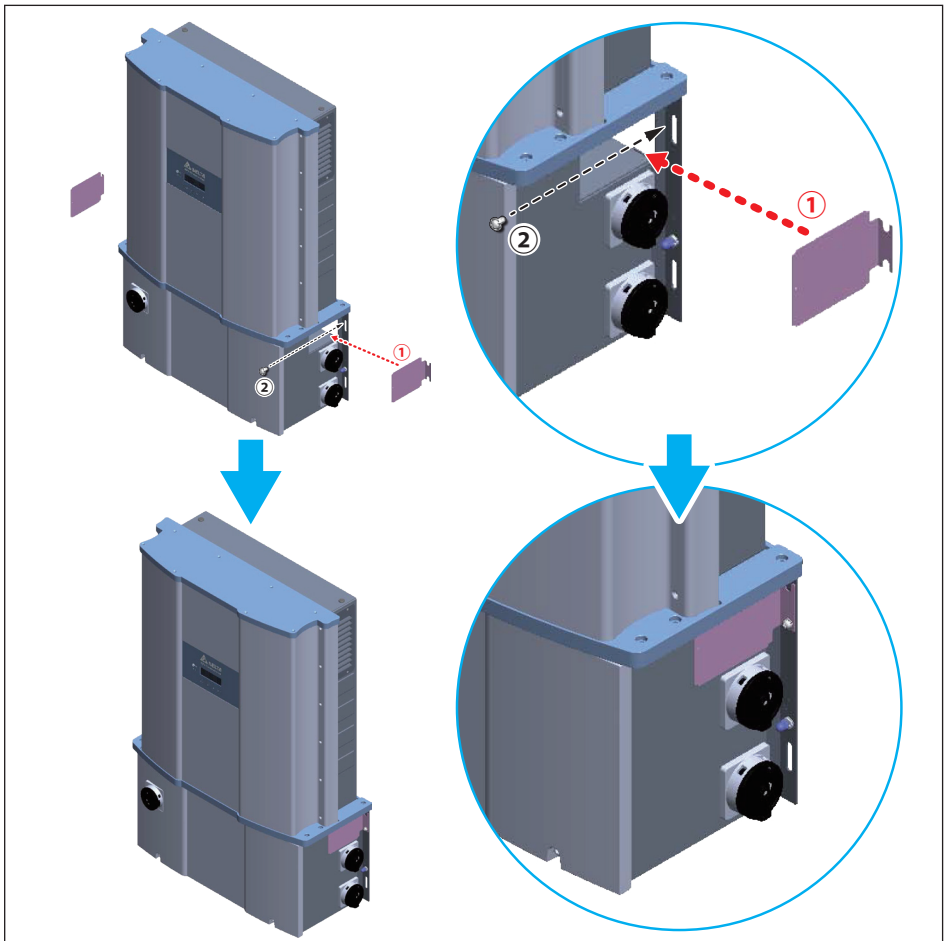

Figure 3-16: Installation method of shielding plate

Name plate cover

CAUTION !



- Please check the front and the back of the name plate cover when installing.
 Small shade: The side with tape is back side.
 Large shade: The side with word "BACK SIDE" is back side.
- After sticking the name plate cover on the inverter, do not remove it in 1 hour to ensure the stickiness of the tape.

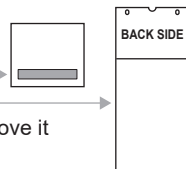

To protect nameplate/LCM from the damage by external factors (like animal, foreign object, UV irradiation etc.), this name plate cover must be installed for tilted/horizontal or exposed in direct sunlight installation.

1 Clean the surface of the inverter.

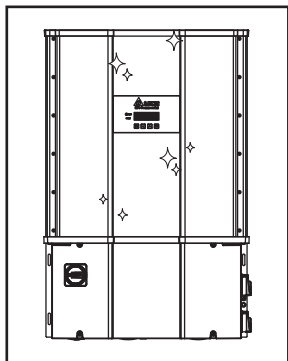

2 Peel off the double-sided tape.

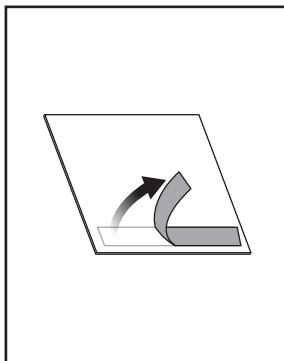

3 ① Insert the small plate into the upper edge of the inverter. Make sure the back side (with tape) is facing inverter.
 ② Stick the plate on the inverter.

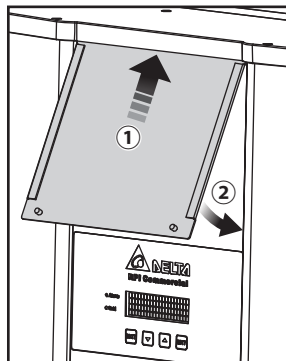

4 Push hard on the plate to ensure the stickiness.

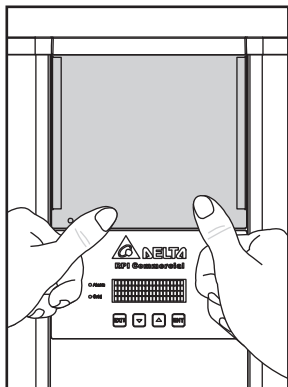

5 ① Insert the large plate into the bottom edge of the inverter. Make sure the front side (with folding) is facing you.
 ② Align screw holes to combine two plates.

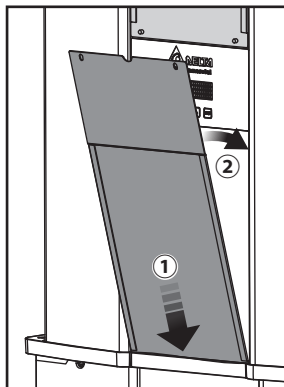

6 Tighten these screws with torque 2 N·m

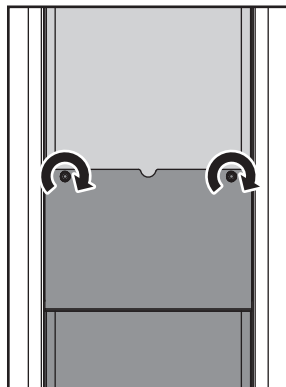

Remove name plate cover

CAUTION !

If there is needed to monitoring or setting the display, please follow procedure below.

1 Loose two screws.

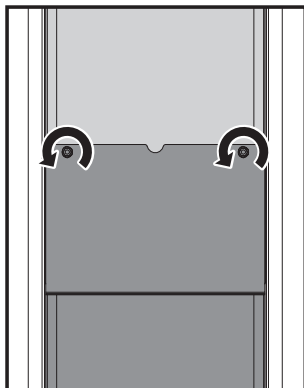

2 ① Separate the large plate.
② Pull out the large plate.

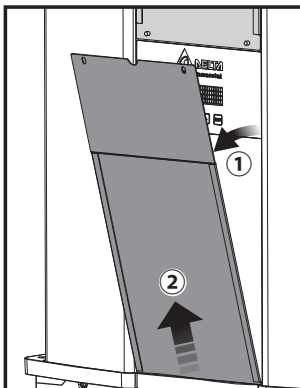

3 Start monitoring or using the display.

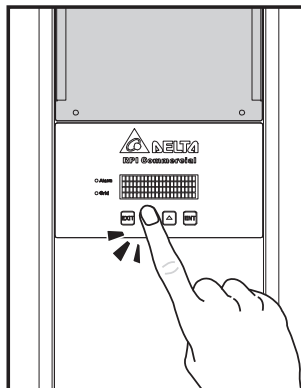

3.2 Wiring box cover

For first time installing/re-installing WB cover, in order to guarantee proper long-term operation of the inverter, procedures in **Section 5.1** must be followed.

3.3 Electrical Installation for AC Wiring

DANGER : ELECTRICAL HAZARD!!



- To avoid shock hazard during cabling, insure any live grid connections are removed from the inverter.

WARNING !



- Installation and commissioning must be performed by a well-trained person (e.g.a licensed electrician) in accordance with local, state, and National Electrical Code ANSI / NFPA 70 requirements.
- Input and output circuits of this unit are isolated from the enclosure System grounding must be done in accordance with the National Electrical Code (NEC).
- Compliance to the local electrical code is the installer's responsibility.
- Inverter warranty void if the DC input voltage exceeds 1000 Vdc.

CAUTION : INVERTER AND EQUIPMENT DAMAGE MAY OCCUR !



- Wire sizes chosen for the AC conductors must meet ampacity requirements of NEC Section 310 or equivalent.
- Wiring method for the AC Installation must comply with the local electrical code.
- Failure to follow the instructions may result in damage to the inverter and AC conductors.

CAUTION : POINT OF CONNECTION !



- The M80/60U solar Inverters must be connected to a 3-phase 480 Vac utility service. NEC 705.12(D)(1) requires that the inverter (every fixed appliance) must be connected to a separate, dedicated circuit breaker (or other approved OCPD) with no other outlets or devices connected to the same circuit (not shared by any other appliance).

CAUTION: WRONG AC WIRING !



- In order not to damage the components in the inverter, ensure the correct conductor is connected to the appropriate AC switch on the inverter.

ATTENTION



- This inverter may be damaged due to moisture or dust intrusion.
DO NOT OPEN the power module section of the inverter.

3.3.1 AC Grid Types and Connections

ATTENTION



The use of a Neutral (N) conductor is optional and depends the grid type and upon local codes. The default AC Grid connection is 3Ø-3W. If a neutral is required, this setting must be changed to 3Ø-4W via the front panel controls. The inverter will operate from the following grid connections without need of an external transformer:

<u>Grid Type</u>	<u>Inverter connection</u>
480V/277V/ 3Ø-4W/Yg,	3W or 4W +EGC
480V/277V/ 3Ø-4W/Y	3W + EGC
480V/3Ø-3W/Δ (ungrounded)	3W +EGC

3.3.2 Required Protective Devices for M80U / M60U

North American electrical codes require a dedicated over-current device such as a circuit breaker in line between the inverter and AC source.

<u>Model</u>	<u>Upstream circuit breaker</u>
M80U	$\geq 125A$
M60U	$\geq 100A$

3.3.3 AC wiring preparation (all models)

Below is the procedure for preparing the AC conductors for connection to the AC terminals (all versions):

- Ensure the AC conductors used are sized to the correct ampacity per NEC or other local code. Refer to **Figure 3-17**.
- Strip off all wires for 14 mm [0.55in].
- The cross-sectional area for each AC conductor is 1~2/0 AWG.
- Please use the AC cable with temperature rating 90 °C or higher.

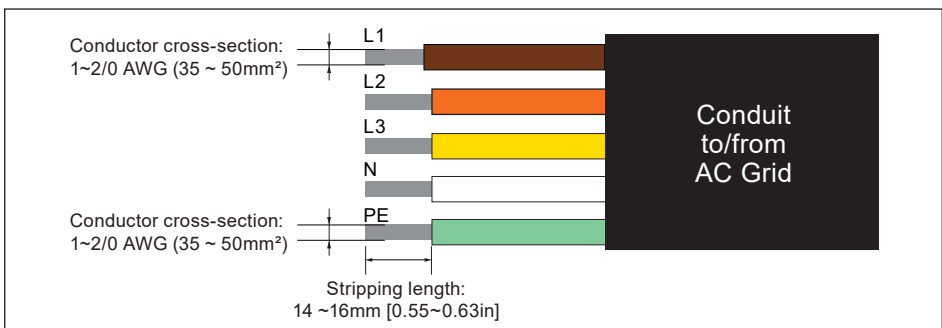

Figure 3-17: Size for AC conductors

3.3.4 AC Switch Terminals –Prewire set-up

The AC switch terminals utilize cage-clamp design terminals and in order to insure proper connection of wiring, prior to inserting stripped conductors into switch terminals complete the following procedure to make terminals ready for connections. For each of the AC switch terminals (L1, L2, L3 and N):

1. Use a flatblade screwdriver loosen the cage-clamps by turning the clamp screw CCW until the screw reaches limit of rotation)
If an electric screwdriver is utilized insure the torque setting is low enough to NOT OVER-TORQUE the screw. Once screw bottoms out, do not turn it any further.
2. Verify visually the cage clamp is in the fully open position

ATTENTION



Please seal the conduit from inside the wiring box by using duct seal to prevent living creature or moisture enter the wiring box.

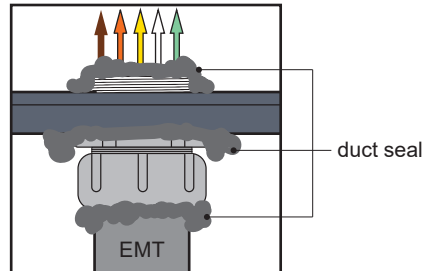

For AL AC wires:

To make sure good conductivity, bi-metal adapter must be used in conjunction with aluminum wires.

NOTICE**Extreme temperature rise at the clamping point**

If the contact resistance between the aluminum conductor and clamping point is too high, the clamping point can become very hot and even catch fire in extreme cases.

To ensure a safe and reliable contact, **always** perform the following work steps:

- ▶ Use a conductor cross-section at least one number larger due to the lower current-carrying capacity.
- ▶ Keep the installation location as free as possible from moisture or corrosive atmospheres.
- ▶ Connect the aluminum cables quickly.
- ▶ Mechanically clean the stripped end of the aluminum conductor (using for instance a knife blade to scrape off the oxide layer). Then immediately dip the aluminum conductor into acid-free and alkaline-free (=neutral) Vaseline and directly crimp the aluminum wire with bi-metal adapter.
- ▶ Tighten the clamping screw in the clamping body with the maximum permissible tightening torque.

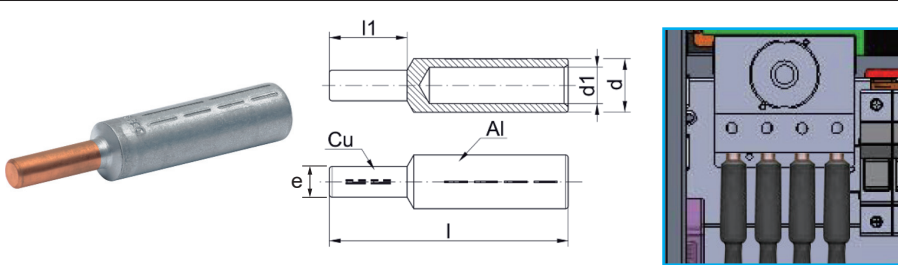

Type: Compression joints
with Cu bolts, Al

For M80/60U, $d \leq 18\text{mm}$, $e \leq 10\text{mm}$
Heat-Shrinkable tube must be applied on Al part

Figure 3-18 : Guideline for bi-metal adapter

3.3.5 AC Wiring for M80/60U_120 models

Figure 3-19 illustrates the location of the AC conduit entry and connections and AC terminal block: for 120 models.

Ensure the AC conductors used are sized to the correct ampacity per NEC or other local code. Refer to **Figure 3-17**.

- Open all AC switch cage-clamps as noted in **Section 3.3.4**.
- Insert stripped phase conductor into appropriate switch terminal.
- Tighten each phase terminal lug to a torque value of 31 lbf-in (3.5 N·m).
- Loosen screw in one of the locations on the ground bar located on the rear wall of the WB chassis.
- There are two options for connecting the PE conduit to the model 120 inverter:
 - Insert the EGC (6~4 AWG) into the ground bar and tighten the lug in the ground bar lug to a torque value of 26 lbf-in (3 N·m). (see **Figure 3-19**)
 - Insert the EGC (1~2/0 AWG) into the grounding screw terminal, torque value of 80 lbf-in (9 N·m). (see **Figure 3-20**)

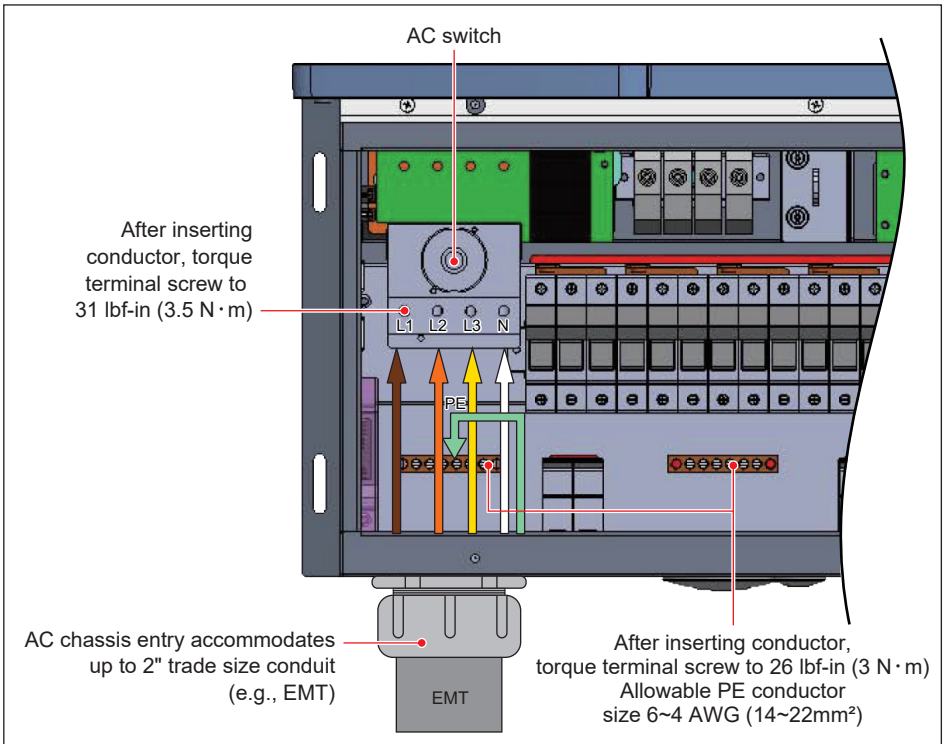

Figure 3-19: Two optional Location of AC terminals and wiring (120 model)

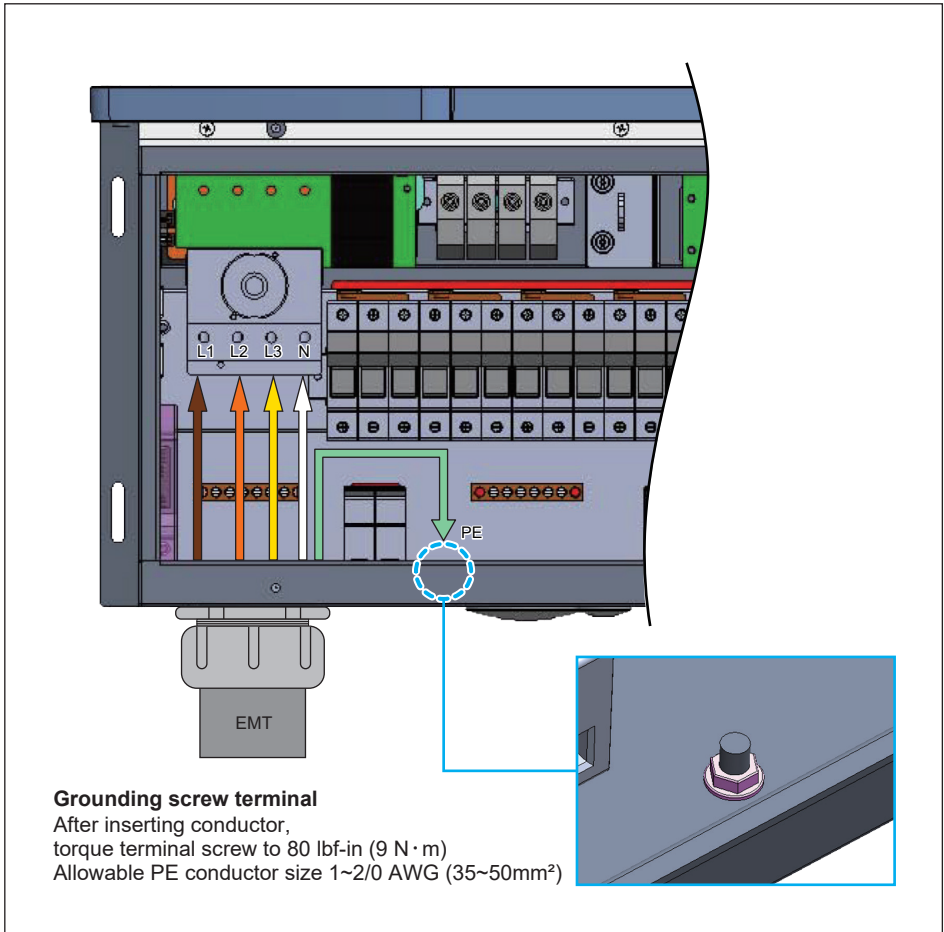

Figure 3-20: Two optional Location of AC terminals and wiring (120 model) (Continued)

3.3.6 AC Wiring for M80/60U₁₂₁ models (With RSD)

Refer to **Figure 3-17** in **Section 3.3** for the procedure to prepare AC conductors for connection to the AC terminals (M80/60U₁₂₁) :

Ensure the AC conductors used are sized to the correct ampacity per NEC or other local code. Refer to **Figure 3-17**.

- Open all AC switch cage-clamps as noted in **Section 3.3.4**
- Ensure the correct conductor is connected to the appropriate terminal.
- After conductor is inserted, tighten L1~N terminal with a torque value of 31 lbf-in (3.5 N·m).
- Insert the EGC (1~2/0 AWG) into the grounding screw terminal, torque value of 80 lbf-in (9 N·m). (see **Figure 3-21**)

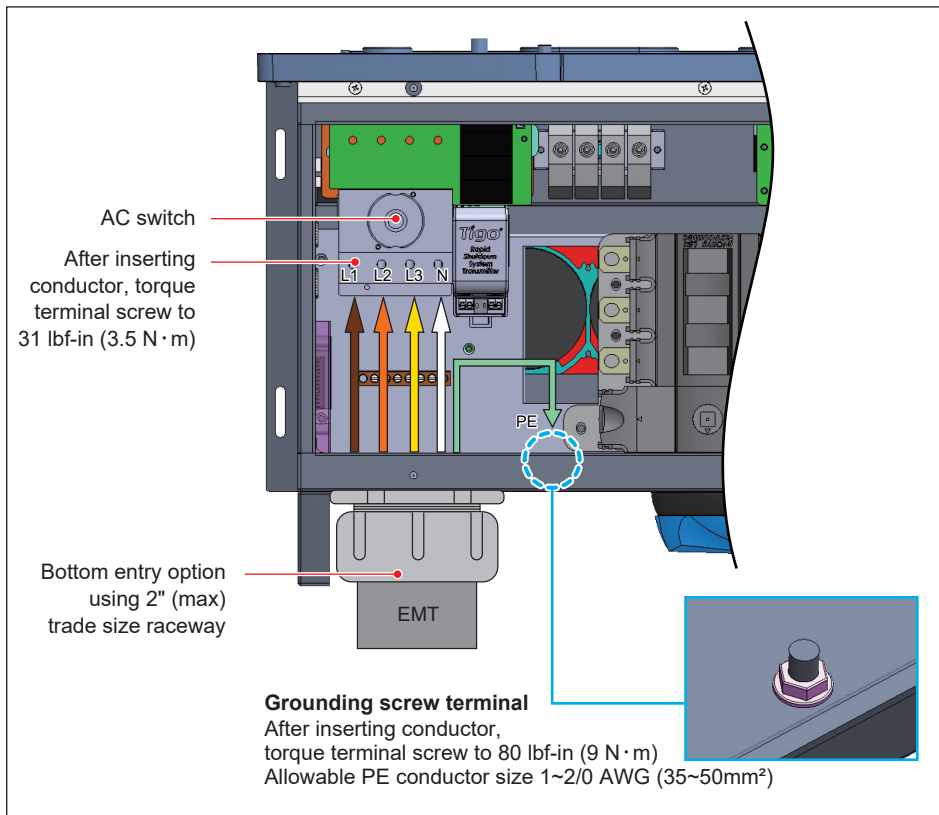

Figure 3-21: Two optional Locations for AC terminal (121 Model With RSD)

3.3.7 AC Wiring for M80/60U₁₂₁ models (Without RSD)

Refer to **Figure 3-17** in **Section 3.3** for the procedure to prepare AC conductors for connection to the AC terminals (M80/60U₁₂₁) :

Ensure the AC conductors used are sized to the correct ampacity per NEC or other local code. Refer to **Figure 3-17**.

- Open all AC switch cage-clamps as noted in **Section 3.3.4**
- Ensure the correct conductor is connected to the appropriate terminal.
- After conductor is inserted, tighten L1~N terminal with a torque value of 31 lbf-in (3.5 N·m), PE terminal with 49.5 lbf-in (5.6 N·m).
- Insert the EGC (1~2/0 AWG) into the grounding screw terminal, torque value of 80 lbf-in (9 N·m). (see **Figure 3-22**)

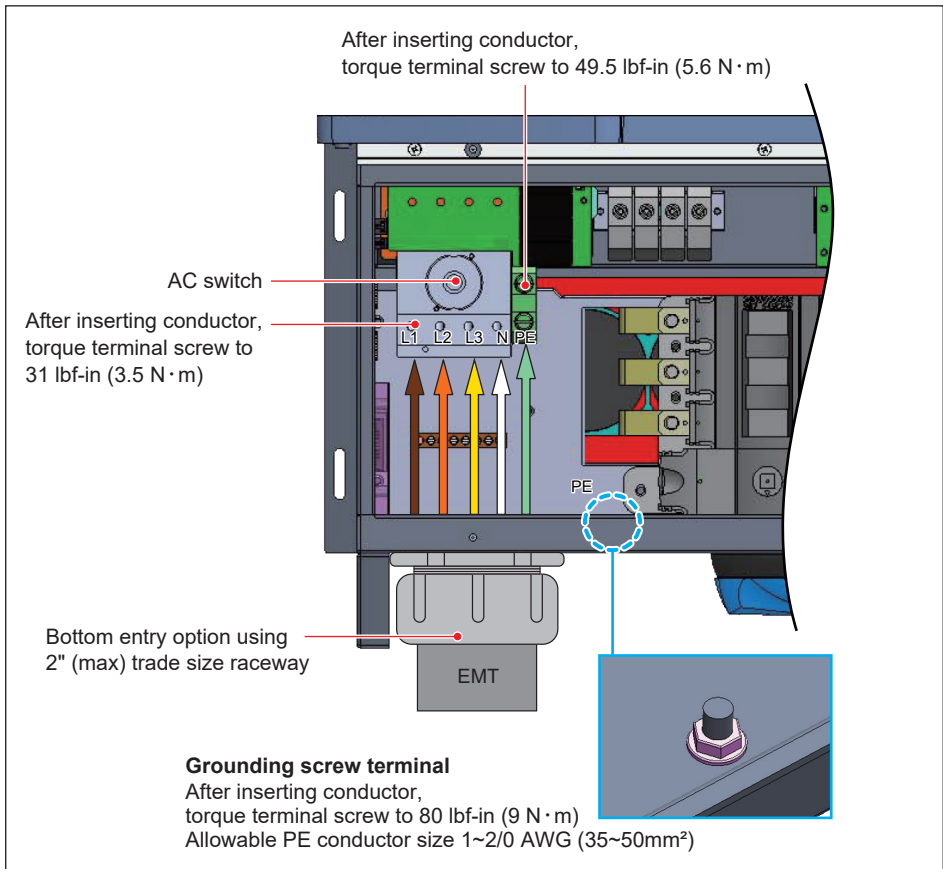

Figure 3-22: Two optional Locations for AC terminal (121 Model Without RSD)

3.3.8 AC Wiring for M80/60U_122 models

Refer to **Figure 3-17** in **Section 3.3** for the procedure to prepare AC conductors for connection to the AC terminals (M80/60U_122) :

Ensure the AC conductors used are sized to the correct ampacity per NEC or other local code. Refer to **Figure 3-17**.

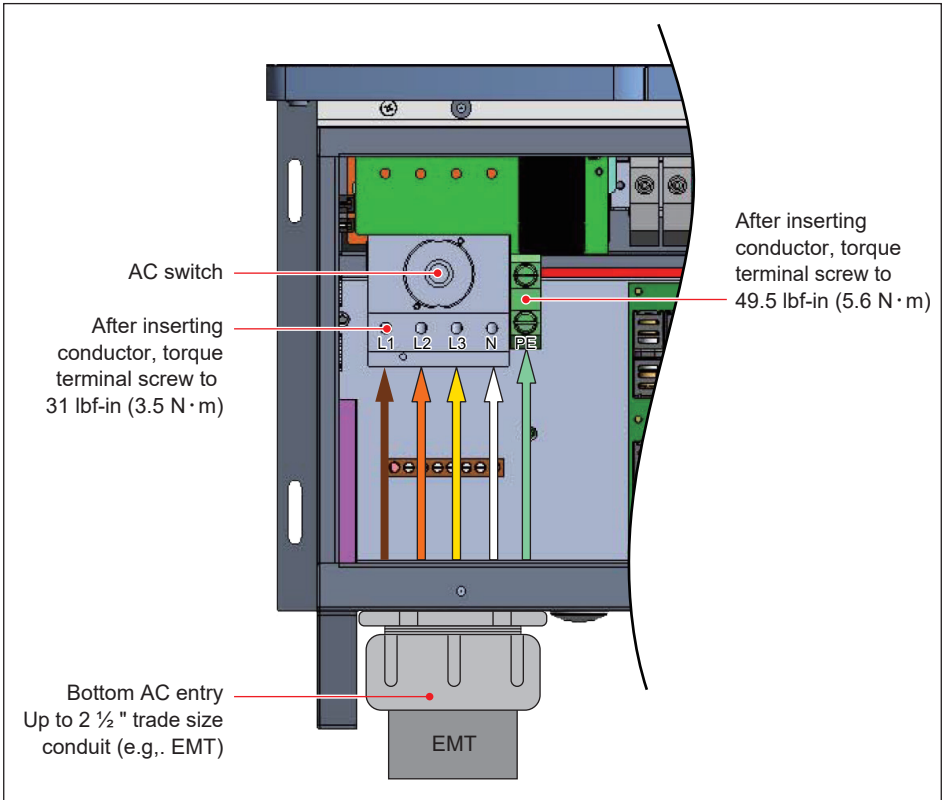

Figure 3-23: Location for AC terminal (122 Model)

Figure 3-23 illustrates the location of the AC conduit entry and connections to the 122 model AC terminal block:

- Open all AC switch cage-clamps as noted in **Section 3.3.4**
- Ensure the correct conductor is connected to the appropriate terminal.
- After conductor is inserted, tighten L1~N terminal with a torque value of 31 lbf-in (3.5 N·m), PE terminal with 49.5 lbf-in (5.6 N·m).

3.4 Electrical Installation for DC Wiring

DANGER : ELECTRICAL HAZARD!!



- PV array converts sunlight into electric power with high DC voltage and high DC current which can cause dangerous electrical shock hazard!
- Use an opaque material to cover the PV array before wiring or cabling.
- Ensure the correct polarities are connected when DC cabling is applied.

WARNING !



- The risk of electric shock and fire exists because of high DC and AC voltages.
- Use only PV modules that are UL Listed to 1000V or higher.
- Ensure the two DC switches are placed in the "OFF" position, and the PV array is disconnected when DC conductors are connected.

CAUTION: DC SWITCH ON/OFF !



- In order not to damage the components in the inverter, don't repeat to change the status of DC Switch quickly, the correct operation is waiting for the LCD display show "No DC" or turn on the switch after 1 minute later.

ATTENTION



- The PV Array current carrying conductors (positive or negative) must not be referenced to ground.

ATTENTION



Please seal the conduit from inside the wiring box by using duct seal to prevent living creature or moisture enter the wiring box.

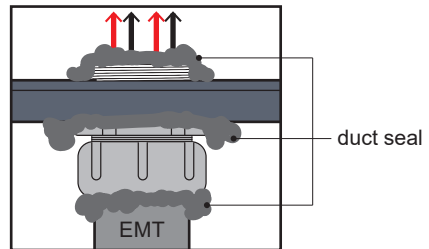

ATTENTION



- For unused DC connectors, please keep the cap on to prevent water or dirt intrusion.

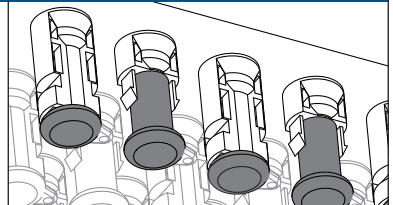

3.4.1 DC Wiring Installation for M80/60U₁₂₀ models

Please read the following instructions for connecting DC terminals (M80/60U₁₂₀) :

- Ensure the DC conductors used are Cu and sized to the correct ampacity per NEC or other local code
- Strip off all wires for 14 mm [0.55in].
- The cross-sectional area for each DC conductor is 14~8 AWG.
- Ensure the fuse holder terminal clamp is open
- Ensure correct conductor is connected to the correct fuse holder.
- Tighten each individual screw terminal screw to a torque value of 24.8 lbf-in (2.8 N·m).
- Two 2" chassis access holes (KOs), one per MPPT can be utilized to connect conduits from PV array DC wiring into the inverter, as shown in **Figure 3-24**.

ATTENTION



- Ensure all fuse holder terminals are tightened to the specified torque value of 24.8 lbf-in (2.8 N·m).

M80/60U₁₂₀

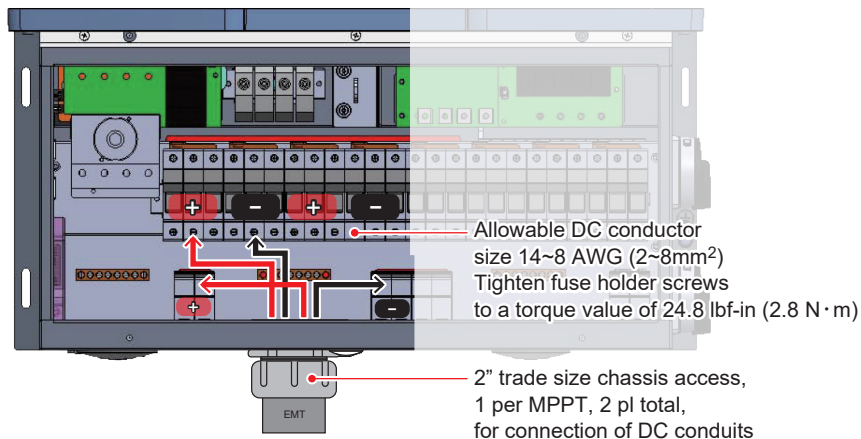

Figure 3-24: Location and string wiring to DC fuse holders for M80/60U₁₂₀ (shown for MPPT 1)

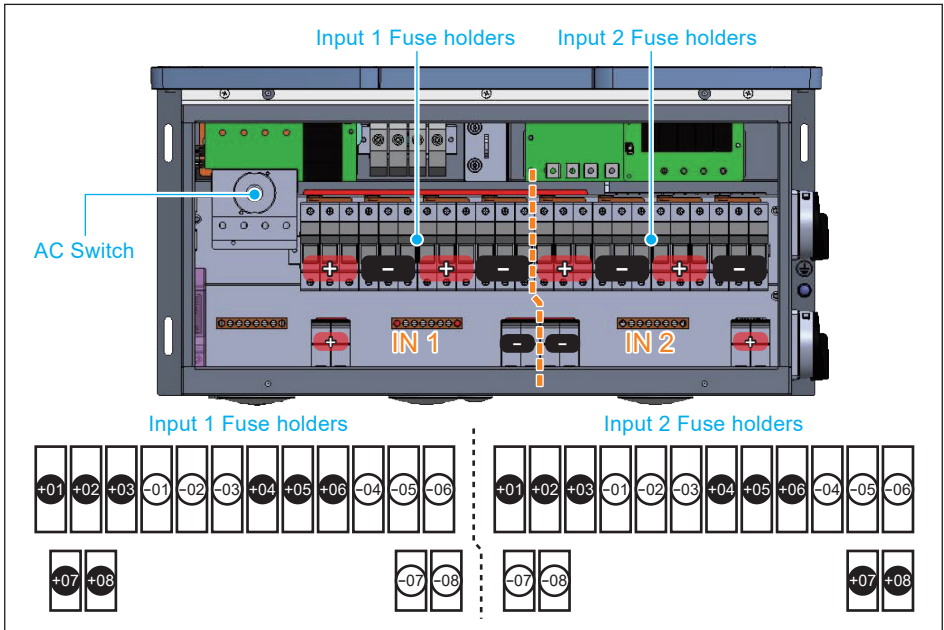

Figure 3-25: Wiring Box layout for M80/60U_120

M80U_120 version is compatible with 1000V/20A UL listed fuse, however, the designer must be beware of the following requirements:

- The max Isc-stc of a connected array (sum of all paralleled strings) cannot exceed the rated Isc limit of the inverter, that is no more than 108A/input or 216A total.
- Because of internal current limitations and higher string currents allowable with 20A fuses, inputs 3 and 6 must not be used.



Figure 3-26: Prohibited fuse location using 20A fuse

CAUTION !



- When 20A string fuses are utilized do not use input 3 or input 6 on either MPPT channel.

3.4.2 DC Wiring Installation for M80/60U₁₂₁ models

Please read the following instructions for DC wiring (M80/60U₁₂₁) :

These models are designed to be utilized with external combiner boxes and are not provisioned with internal DC combining capability.

- Specific size of DC conductors must be determined from NEC or other local codes.
- Ensure the correct conductor is connected to its associated terminal with ring lug (max width ≤ 25mm).
- The range of conductor sizes accommodated by each DC terminal is 1~3/0AWG. Tighten each terminal with screw (M6) with a torque value of 52 lbf-in (5.9 N·m).
- For aluminum cable :
 Min./max. Conductor cross-section 35 / 70 mm²
 Tightening torque 52 lbf-in (5.9 N·m)
- For the 121 model, two mounting options for installing the DC connection are available, bottom (2" chassis access hole (KO)) or side entry (2½" chassis access hole (KO)). If side entry is required, remove the bus bar with torque value 159.3 lbf-in (18 N·m) as shown in **Figure 3-30**. After removing the bus bar, if the bottom entry is again required, install the bus bar back with torque value 159.3 lbf-in (18 N·m).

ATTENTION



- Please follow the following guideline for cabling if you use aluminum cables. Guideline for aluminum conductor :
 - The oxide layer must be removed from the surface of the stripped aluminum conductor.
 - The stripped aluminum conductor is greased with Vaseline or contact grease with comparable properties after oxide layer removed.
 - Tightened with the maximum tightening torque for the modular terminal block.
 - The installation location must be kept free from humidity or aggressive atmospheres.

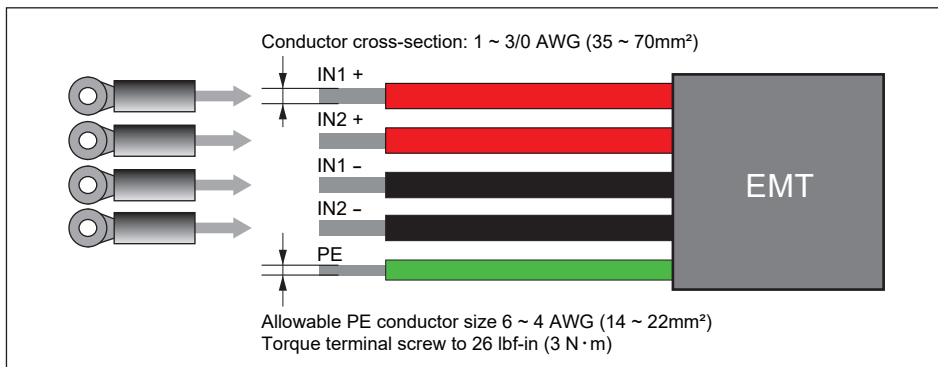
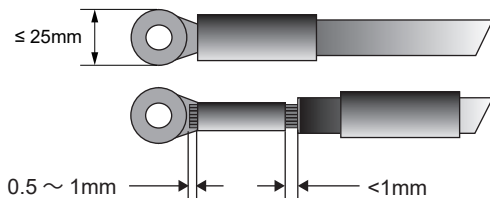

Figure 3-27: Size for DC conductors for M80/60U₁₂₁

- Please follow below instruction for wire crimping.



- To make sure good wire conduction, bare wire should not exceed the edge of crimping part of lug for more than 1mm.

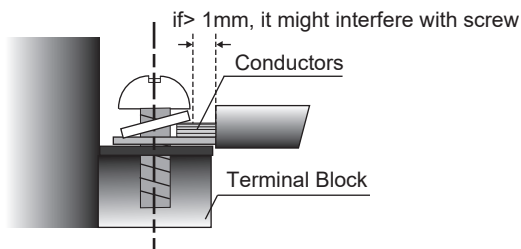

Figure 3-28: DC terminal lug for M80/60U_121

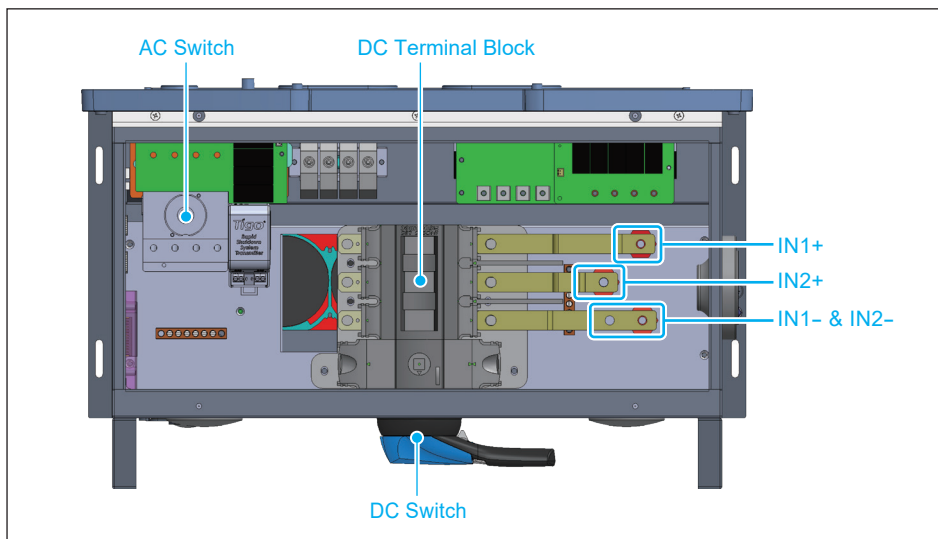

Figure 3-29: Wiring Box layout for M80/60U_121

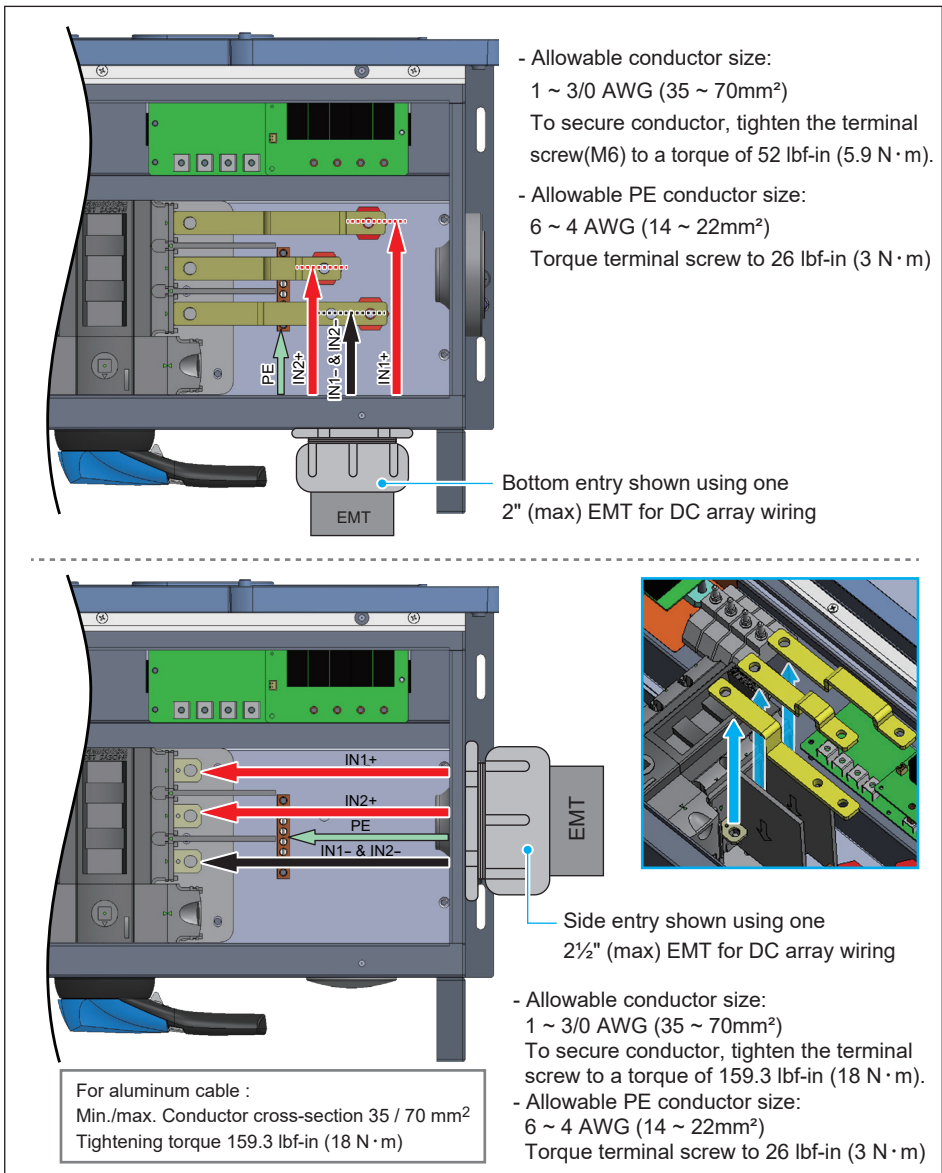

Figure 3-30: Location for DC terminals for M80/60U_121

ATTENTION



- Torque for removing/installing bus bar: 159.3 lbf-in (18 N·m)

The Tigo RSS Transmitter has a range limit. The entire DC loop for each string, from the positive terminal on the inverter, out through the array, to the negative terminal on the inverter, should be less than 1000 feet (300 meters). Please go to Tigoenergy website for more details.

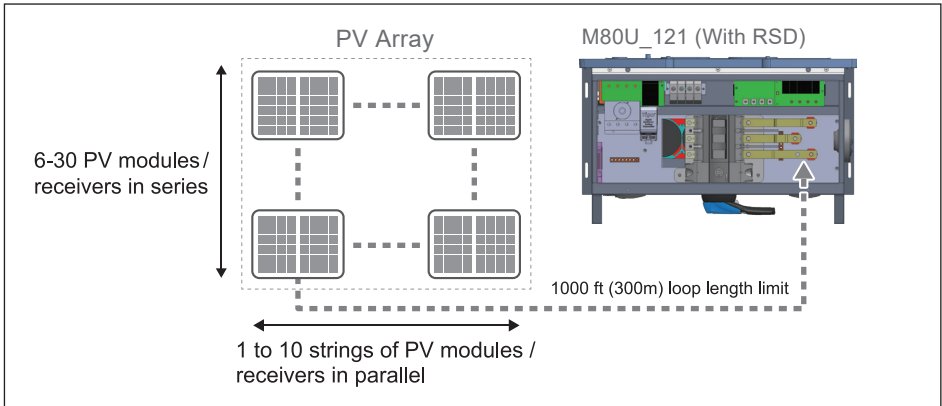

3.4.3 DC Wiring Installation for M80/60U_122 models

122 models use bulkhead mounted MC4 type connectors for interconnecting string wiring to the inverter. Mating connectors (See **Figure 3-31**) are provided within the hardware bag.

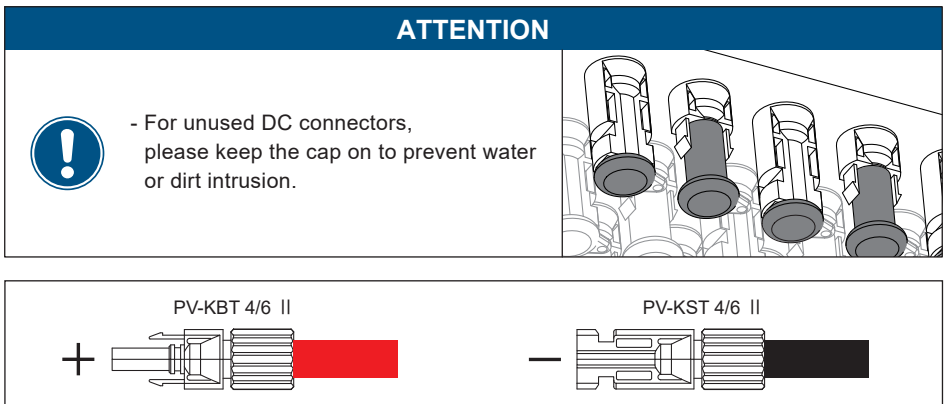

Figure 3-31: DC Wiring illustration

- Choose the DC string wire size based on NEC requirements
 - The cross-sectional area for each internal cable is 12~10 AWG (4~6mm²).
- DC wiring polarities are divided into positive and negative, and the layout between the connectors and associated internal fuses is shown in **Figure 3-32**.

M80/60U_122

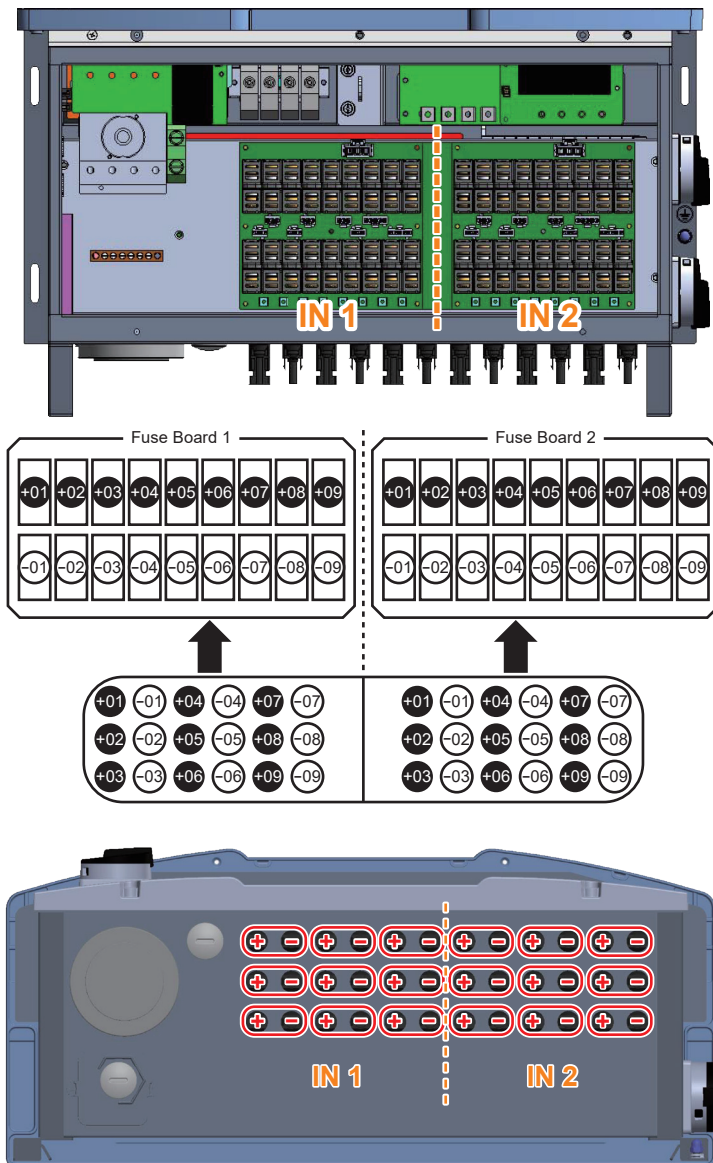

Figure 3-32: Wiring Box layout and Bottom view of inverter chassis showing location of MC4 connectors used to connect array wiring (DC) to M80/60U_122

3.4.4 Ground bar locations

Figure 3-33 shows the DC grounding bar locations.

The wire gauge of the ground cable: 6AWG ~ 4AWG

Torque grounding cables to 26 lbf-in (3 N · m)

-120 Model WB

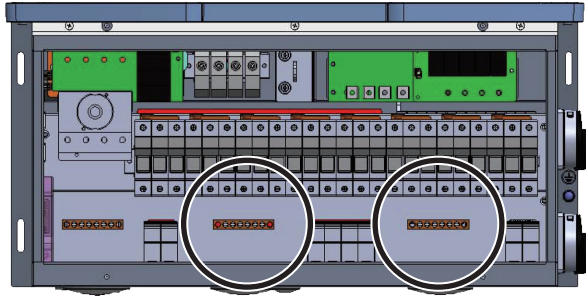

-121 Model WB

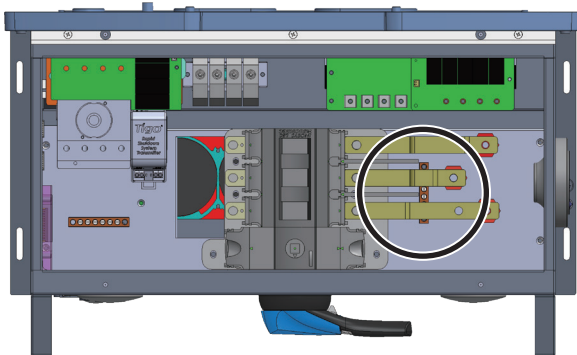

-122 Model WB

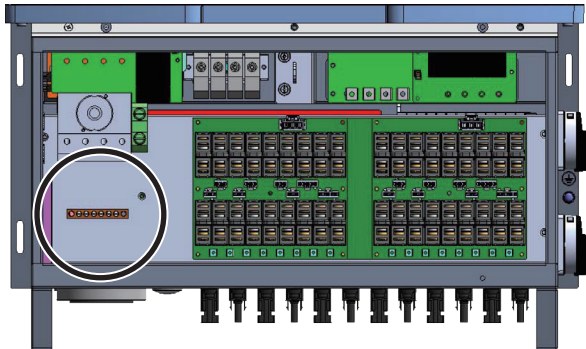

Figure 3-33: Ground bar locations

3.4.5 DC side ground bar for 121/122 models

After installing the unit, locate the ground bar and associated screws in accessory bag. Be sure to orient the ground bar as shown in **Figure 3-34**. Torque the mounting screws to: 22 lbf-in (2.5 N·m)

The busbar accommodates grounding conductors in the range of 6AWG ~ 4AWG
Torque grounding conductors to 26 lbf-in (3 N·m)

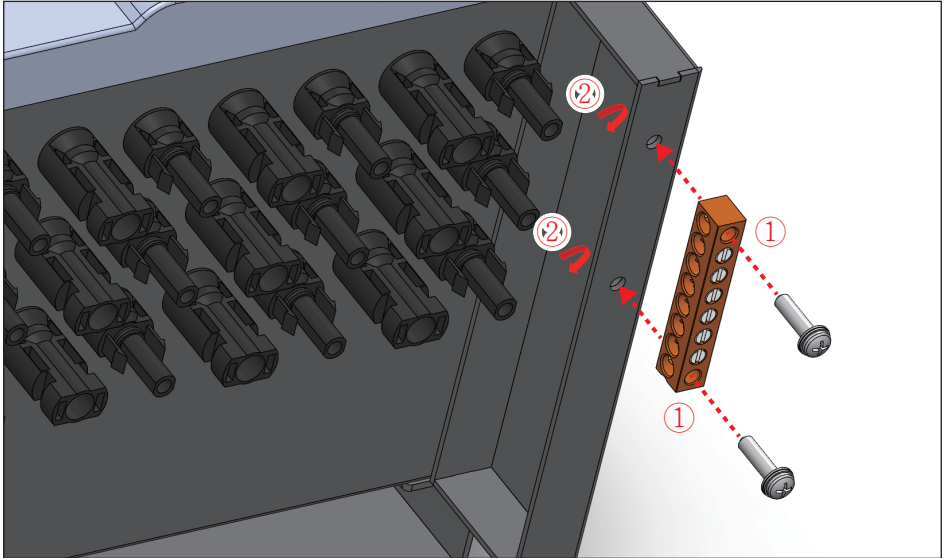

Figure 3-34: Mounting the DC side ground bar to 121/122 WB

3.5 Communication Module Connections

The communication module of M80/60U is shown in **Figure 3-35**. It provides VCC, RS-485, Rapid shutdown system connection, EPO, and Digital Input terminals for use in various applications. Details for each are presented below. There's a 12VDC source between VCC & GND for use with external device.

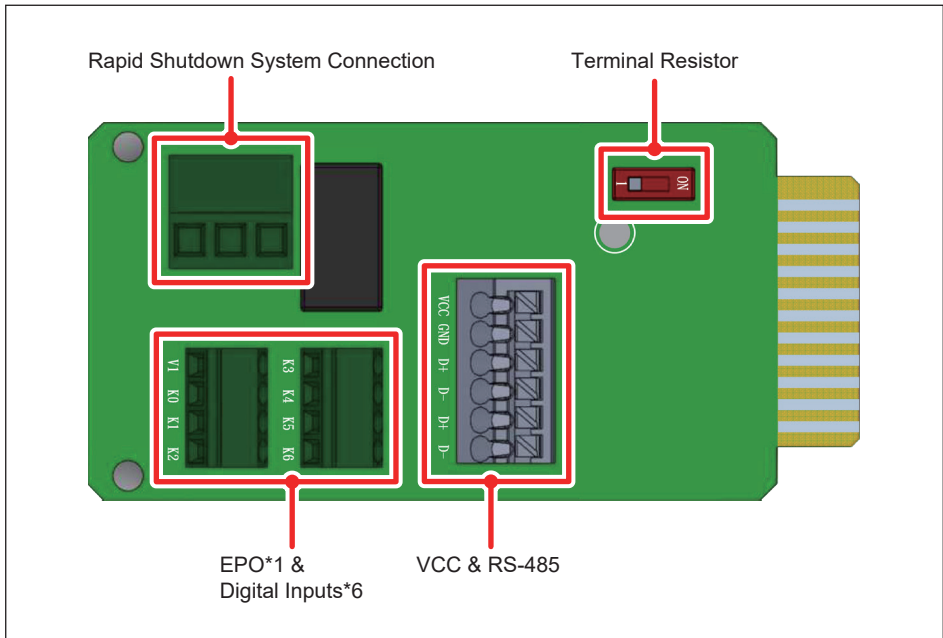

Figure 3-35: Communication Module Layout

3.5.1 Accessing the Communication Module

The communication module consists of an assembly with a PCB and a plastic carrier. It is located in a slot through the bottom of the wiring box chassis.

It is accessed from the bottom exterior of the wiring box. The carrier is secured to the chassis by two self-retaining screws. See **Figure 3-36**.

To access the communication module, loosen the two self-retaining screws to loosen the carrier from the chassis. Once loosened completely, the card/carrier module can be withdrawn from the wiring box chassis by gently pulling the carrier straight out from the chassis.

After pulling the desired signal cable(s) through the wiring gland provided or a connected conduit, and connected electrically as shown in the following sections, the module can be reinstalled by reversing the above directions. Ensure the assembly is oriented into the chassis so as to allow the edge connector to engage properly.

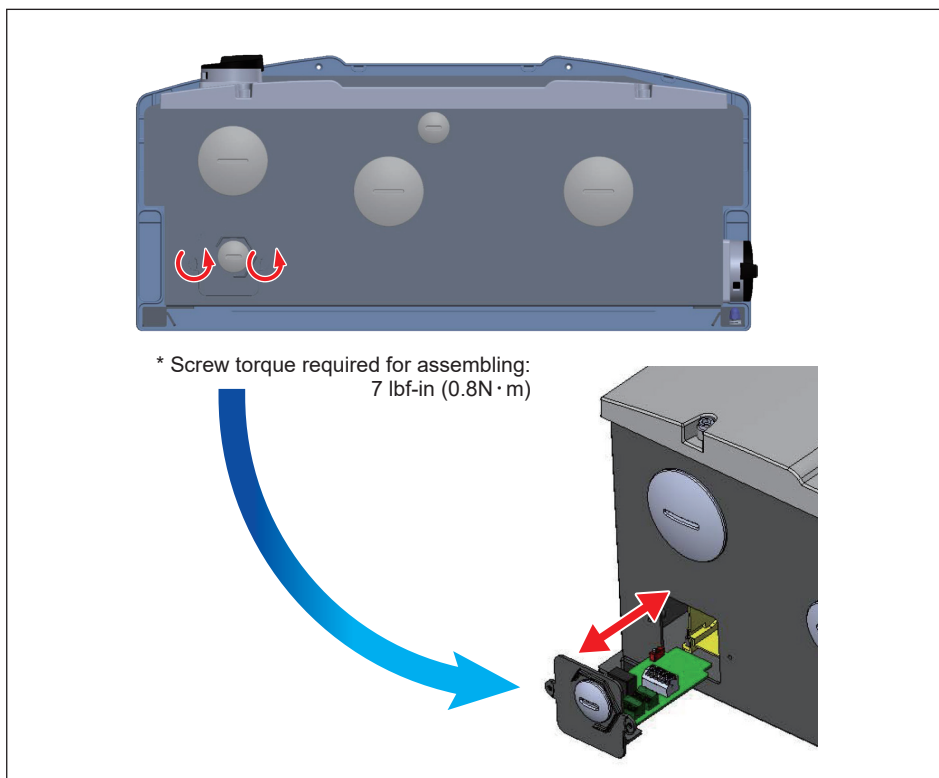

Figure 3-36: Location and access to Communication Module

3.5.2 RS-485 Connection

The pin definition for the RS-485 terminal block is shown in **Table 3-1**.

- Pins 1 and 2 provide a 12V_{DC}/0.5A bus for use with accessories such as R3 Power Monitor.

*** To avoid nuisance trip of rapid shutdown system (RSS), if 12V AUX power is used to power on transmitter of RSS with AC interlock purpose, do not connect additional load on 12V AUX power.**

- Pins 3 and 5 are both connected to the DATA+ input.

- Pins 4 and 6 are both connected to the DATA- input.

These connections allow easy daisy-chaining of multiple inverters.

A 120ohm bus termination resistor and associated control switch are located on the communication board (See **Figure 3-37**) The switch function is as shown in **Table 3-2**.

Different RS-485 connection scenarios require different set up for the 120ohm bus termination resistor.

- When several inverters are cascaded (i.e., "daisy-chained") only the last inverter in the chain must have its bus termination resistor switched ON. Refer to **Figure 3-37**.
- If the length of any RS-485 bus is greater than 2000' (610m), the use of Belden 3105A cable (or eq.) is recommended to insure communication quality. (When using R3 Monitor, a 4-wire cable is required; Belden 3108A (or eq.) is recommended.)

ATTENTION



In order to have good transfer quality, twisted-pair wire is recommended to be used as communication cable.

Pin	Function
1	VCC (+12V)
2	GND
3	DATA+
4	DATA-
5	DATA+
6	DATA-

Table 3-1: RS-485 Terminal block wiring

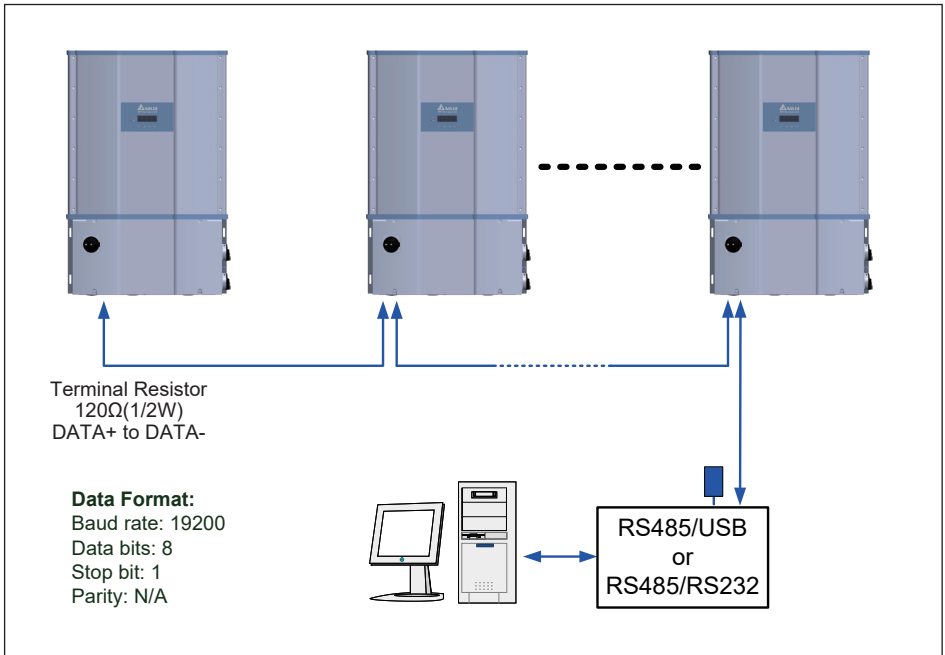

Figure 3-37: Multiinverter connection illustration

	Switch 1
ON	Terminal Resistor ON
OFF	Terminal Resistor OFF

Table 3-2: Vcc and Bus Termination switch settings

3.5.3 EPO Function & Digital Input

The communication Module has an emergency power off function (EPO), and EPO enable can be found in the Install Settings page.

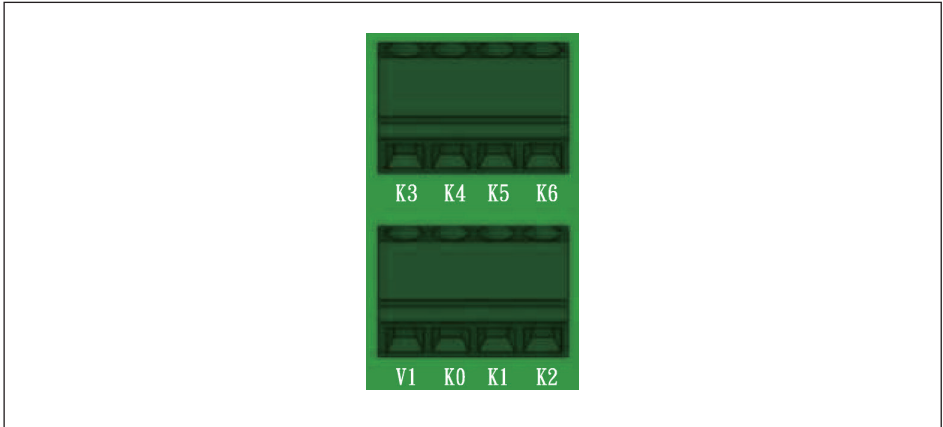

Figure 3-38: EPO function terminal block

Once enabled, the EPO function can be used to turn off the inverter via a NO relay contact connected across terminal [V1 & K0].

Additionally, a digital power reduction control is available that can be set to limit the inverter's available active output power. The control settings for this function are made by placing a hardware short (jumper or relay) between two terminals of the terminal block shown in **Table 3-3**, below.

Short terminals	Inverter's action
V1 & K0	Emergency power off (EPO)
V1 & K1	0% active power
V1 & K2	Maximum 30% rated power
V1 & K3	Maximum 60% rated power
V1 & K4	Maximum 100% rated power
V1 & K5	Reserved
V1 & K6	Reserved

Table 3-3: Definition of digital input & EPO function

3.5.4 Rapid shutdown system connection

The M80/60U series provides a terminal to control the rapid shutdown system(RSS) which supports NEC 2017 requirement for the roof-top PV system. This terminal provides a 12VDC, Max. 1A power in normal condition but the power will turn-off in 2 seconds when the AC grid outage.

The terminal block for this function is shown in **Figure 3-39**.

- AWG 22 to 12 solid or stranded wire is available for the terminal hole and wire length is limited to 10M.
- Stripping length is 6 ~ 7 mm.
- 2.5 N·m rated torque to connect the wires.

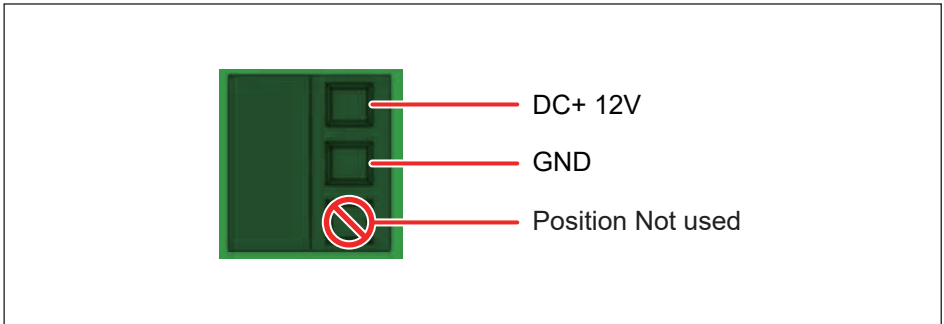

Figure 3-39: Rapid shutdown system connection

3.6 On-site insulation test

For customers who want to do on-site insulation test, please make sure:

1. The DC switches are in “OFF” position.
2. Apply one probe to the positions shown in **Figure 3-40**, the other to the ground. It might cause damages to the inverter if probes are applied to inappropriate positions.

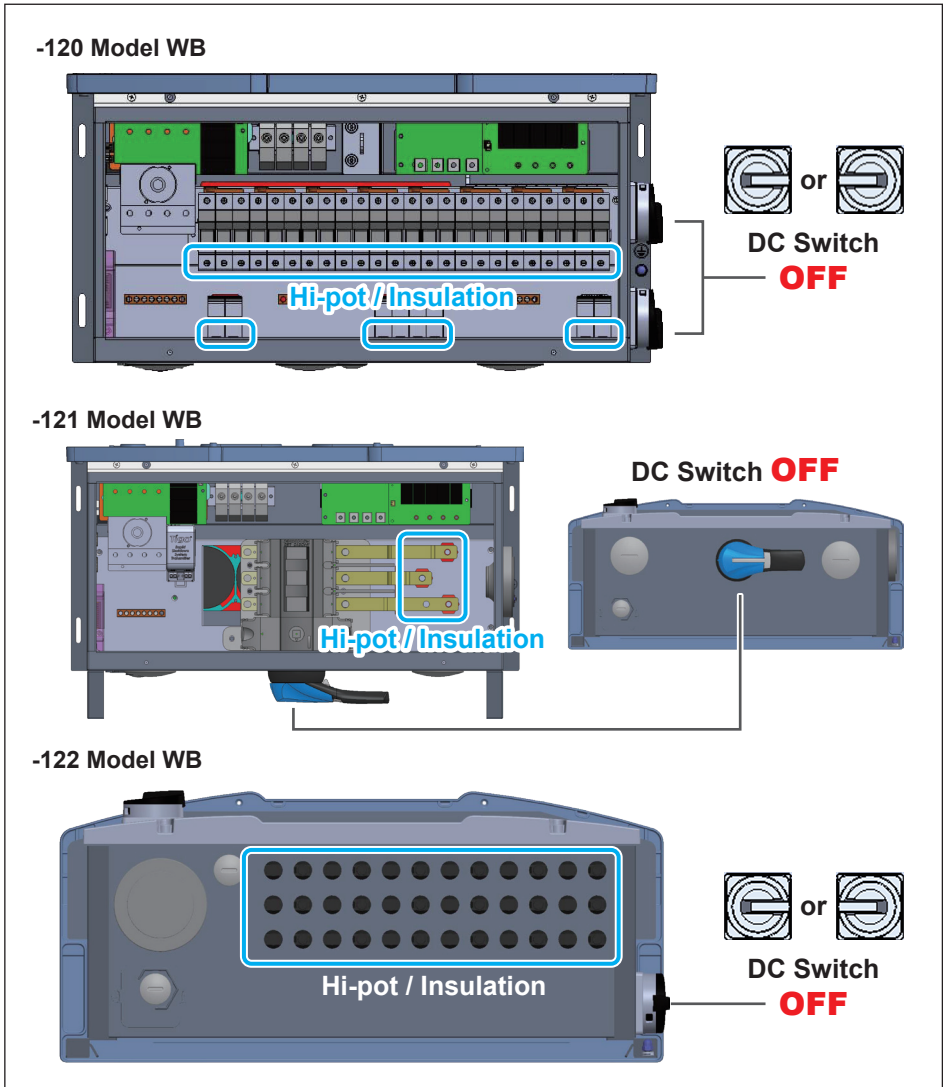

Figure 3-40: Precautions for on-site insulation test

4 Commissioning

CAUTION : HOT SURFACES, DO NOT TOUCH!



- Use care to avoid hot surfaces when operating the product!
- Do not perform any task until the unit cools down or appropriate personal protection gear is worn.

4.1 Display Operation Introduction

M80/60 series include a front panel 4x20 character LCD display which includes four programming keys and 2 LEDs (located on the left-hand side of the LCD) that allow visual display of the inverter’s data and status as shown in **Figure 4-1**. Please refer to **Table 4-1** for information as to the information provided by the LED indicators.

Access to various screens and the adjustment of inverter settings are done using the LCD screen and the four programming buttons directly below the LCD screen, See **Table 4-2** for programming descriptions of operation.

When adjusting settings, LCD panel will change the display cursor from “▶” to “➔”

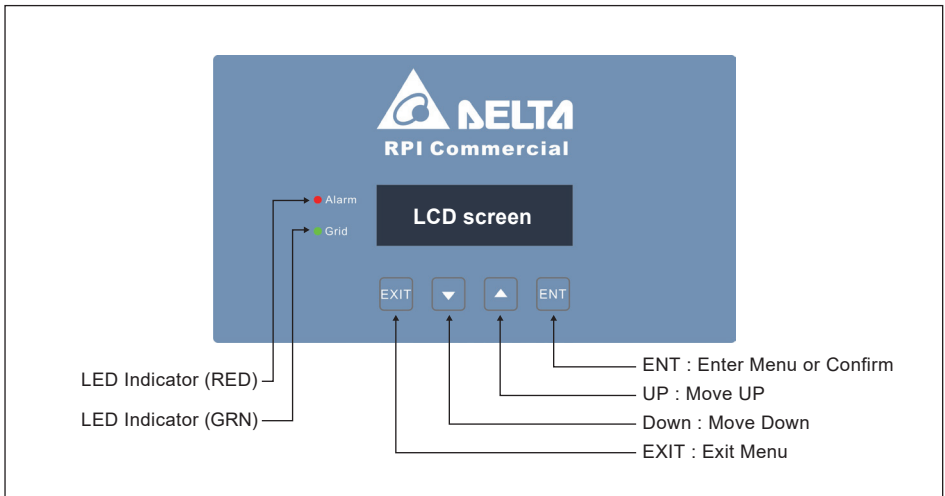

Figure 4-1: Front Panel Display

Condition	Green LED	Red LED
Countdown	FLASH *	OFF
Power ON	ON	OFF
Error or Fault	OFF	ON
Standby or Night time (No DC)	OFF	OFF
Bootloader mode	FLASH *	

* ON 1s / OFF 1s

Table 4-1: LED indicator

Button	Symbol	Action
Enter	ENT	Enter a Menu or Confirm a programmed value
UP	▲	Move cursor UP in menu or increase a programmed value
Down	▼	Move cursor Down in a menu or decrease a programmed value
Exit	EXIT	Exit Menu

Table 4-2: Programming keys and actions

4.2 First startup

At the time of initial startup, a First Start routine is started allowing user to set basic functions without need of a password. An appropriately sized PV array and an AC grid must be available and connected to the inverter. Procedure is as follows:

- Complete the appropriate system pre-commissioning procedure(s).
- Initially, ensure both DC switches are in OFF position, and interconnect the inverter to the AC grid by turning on internal and any external AC switches as required.
- Verify the inverter control system is powered by noting that the LCD display panel has become active.
- During the initial startup, when the LCD display become active, the inverter control will enter the **First Start-up** routine which allows installer to set Language, Grid code, RS-485 protocol and inverter ID (RS-485 address). **Figure 4-2** below, illustrates the display flow charts of the inverter startup.
- Using display and programming keys, set desired language and the country (Grid Code) associated with the installation location and wait for the AFCI Self Test to complete.
- Verify AFCI self test result is a pass.
- Close both DC switches, and await inverter to complete its self test sequence, which takes approximately two minutes.
- Verify via the display there are no errors, faults or warning indications displayed on the home page.
- If there is sufficient power available from PV array, inverter will connect to grid and begin exporting power to the grid.

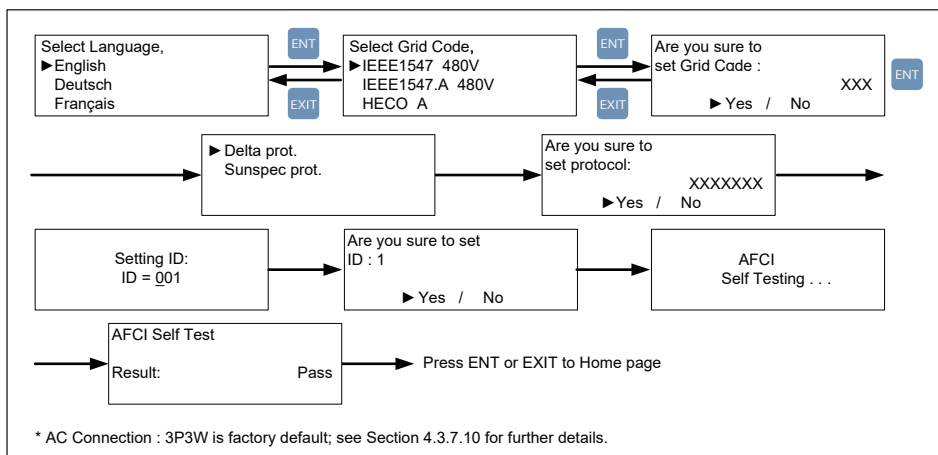

Figure 4-2: Grid code, language and ID settings for first start-up

The following sections indicate inverter status and settings as shown on the LCD display.

4.2.1 Home Page

After completion of First Start and inverter is in normal operation, the LCD will display the homepage screen as shown in **Figure 4-3**. The user can view information to include output power, inverter status, E-today, date and time.

Pressing "any" key in home page mode will open the main menu. To return to Home Page screen, press EXIT at main menu or wait 5 minutes without any key operation, the display will return to homepage.

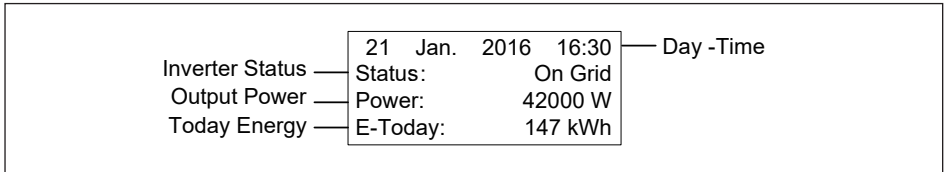

Figure 4-3: Home Page screen

4.3 Main Menu

Table 4-3 contains a listing of all inverter functions that can be adjusted by users (U) and installers (I) via the LCD panel, and the associated manual subsection where a description of the operation of each is found.

Function	Para	Access	Function	Para	Access
Power Meter	4.3.1	U,I	Grid Settings	4.3.7.4	I
String Current Mon	4.3.2	U,I	PID	4.3.7.5	I
Energy Log	4.3.3	U,I	RCMU	4.3.7.6	I
Event Log	4.3.4	U,I	Emergency Power-Off	4.3.7.7	I
Information	4.3.5	U,I	AC Connection	4.3.7.8	I
General Settings	4.3.6	U,I	Anti-Islanding	4.3.7.9	I
Install Settings	4.3.7	I	AFCI	4.3.7.10	I
Inverter ID	4.3.7.1	I	Grid code confirm	4.3.7.11	I
Insulation	4.3.7.2	I	Active / Reactive power	4.3.8	I
Grid Code	4.3.7.3	I			

Table 4-3: Inverter Functions

4.3.1 Power meter

This page displays voltage, current and power measurements from both the AC and DC side.

4.3.2 String monitoring (M80/60U_122)

The string current monitoring function is accessed via the Power Meter menu. Four sub-pages are accessed using display keys as shown in **Figure 4-4**, two pages display string current values for the nine strings of MPPT1 and MPPT2.

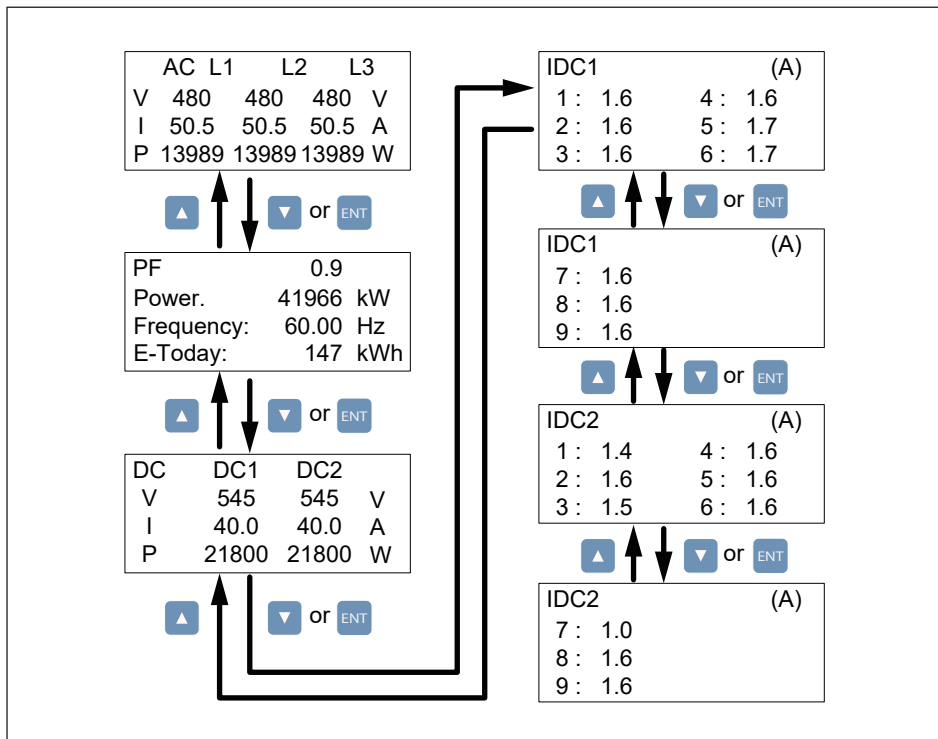

Figure 4-4: Power Monitoring and String Current Monitoring (_122)

4.3.3 Energy Log

User can view the inverter's lifetime energy runtime via Energy Log page.

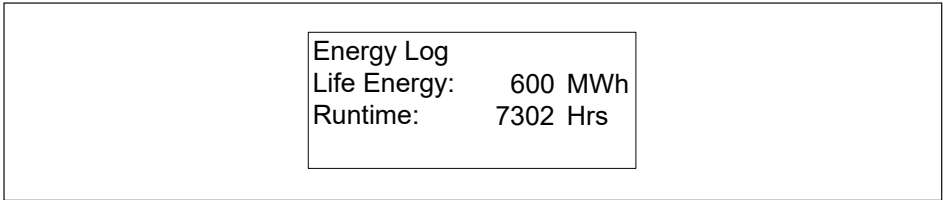

Figure 4-5: Energy Log screen

4.3.4 Event Log

Event Log display has two sub-pages as noted below and shown in **Figure 4-6**:

- **Error Events page** displays all the events (Error and Fault) and can show 30 records at a time.
- **Grid Report page** only displays the error that occurred at grid side, and it can show 5 records at a time.

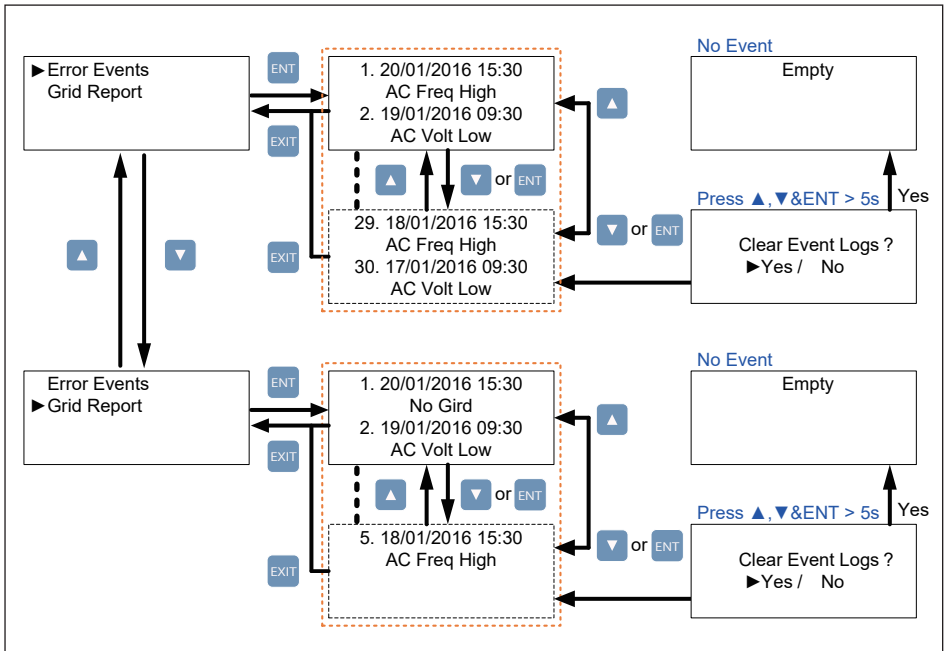

Figure 4-6: Event Log screens

4.3.5 Inverter Information

This page allows the user to view static data associated with the inverter to include serial number, installation date, inverter ID (RS-485 address), and firmware version. Additional parameters are accessed via connected menus using the up/dn keys. Programmed settings (e.g., Inverter ID, baud rate) are adjusted using the settings menu. The complete list of inverter information items can be seen in **Figure 4-7**, below.

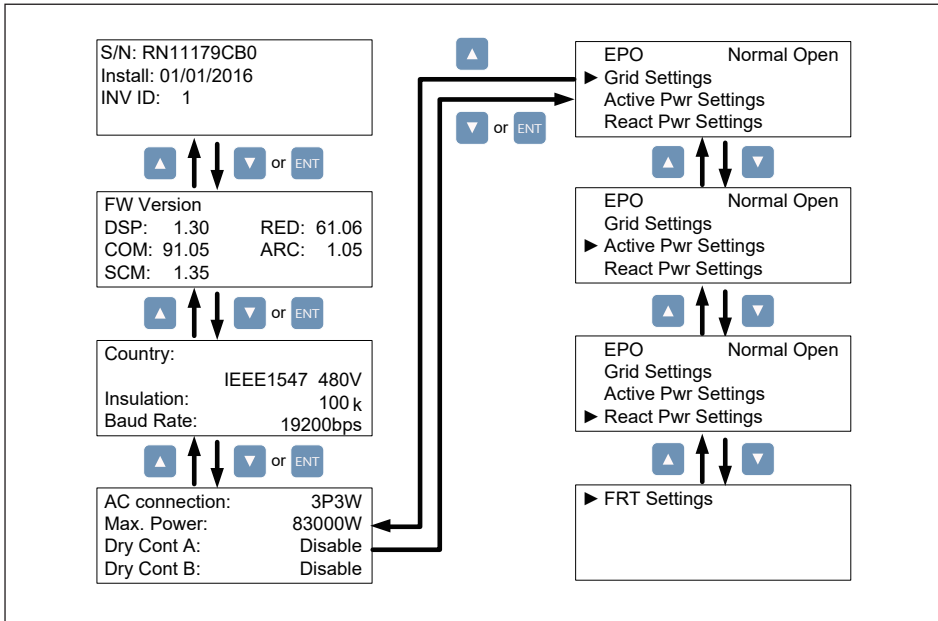

Figure 4-7: Inverter Information screens

4.3.6 General Settings

This page allows the setting of Language, Date and Time, and RS-485 baud rate via sub-menus. Use UP/DN arrow keys to navigate to desired sub-menu, and then press ENT to enter the chosen sub-menu.

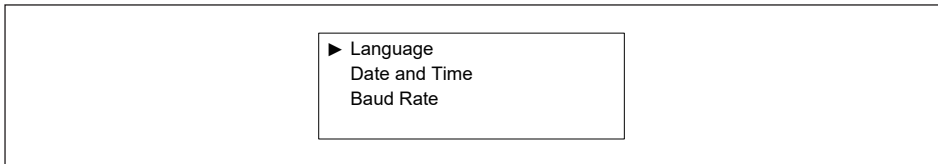

Figure 4-8: General Settings screen

4.3.7 Install Settings

CAUTION !



- Changing the settings in the Install Settings page can result in damage to the inverter and other equipment. These settings must only be adjusted by qualified installers or engineers.

To enter Install Settings page, users must enter a valid password, which must be obtained from Delta Electronics. There are three sets of password with different permissions: User Level, Installer Level, and Manufacturer Level. The following sub-sections will introduce the parameters settings accessible from the User and Installer level menus of the Install Settings page.

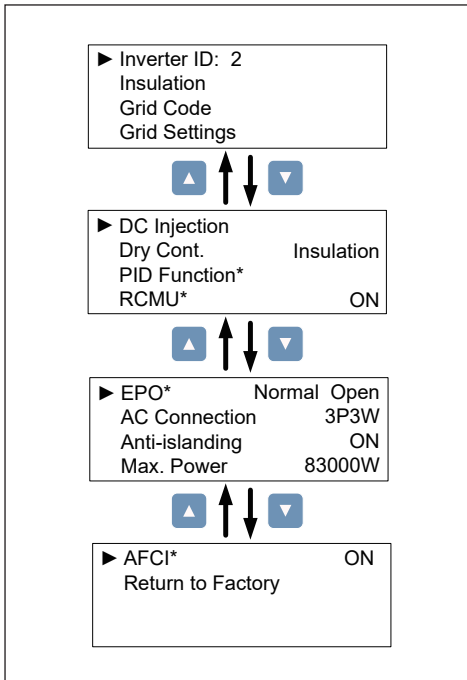

Figure 4-9: Install settings Display screens

User Level:

- Inverter ID
- Insulation
- Grid Code
- PID Function*
- EPO*
- AC Connection
- Max. Power

Installer Level:

- All above User Level plus
- Grid Settings
- Active Power Settings
- Reactive Power Settings
- DC Injection
- RCMU*
- Anti-Islanding

Manufacturer/Factory Level:

- All above Installer Level Settings

*PID	Potential Induced Degradation (see section 4.3.7.6)
*RCMU	Residual Current Monitoring (see section 4.3.7.7)
*EPO	Emergency Power Off function (see section 3.5.3)
*AFCI	DC arc fault current interrupter (see section 4.3.7.11)

Table 4-4: Controls Access Levels

4.3.7.1 Inverter ID

Inverter ID is the RS-485 address which is assigned to the inverter and used when the RS-485 communication system is operating, e.g., connected to a PC or data logger. If several inverters are connected to the RS-485 bus, each must have a distinct Inverter ID. Allowable ID values are 1-254. Consult data logger manufacturer to determine maximum number of inverters on a single RS-485 bus.

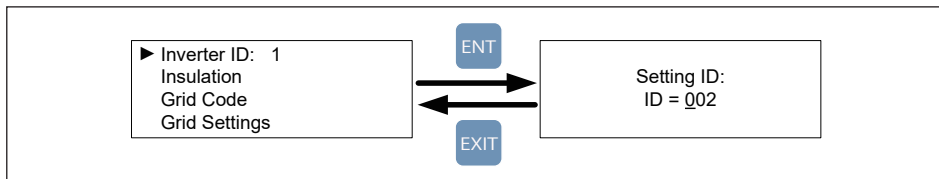

Figure 4-10: Inverter ID screen display

4.3.7.2 Insulation

Prior to connecting to grid, the inverter control will measure the impedance between the floating PV array(s) and ground (PE), also known as isolation resistance, RISO. This measurement is compared to an internal limit and used to determine if any ground fault is present in the array prior to connection of the inverter to the grid.

The inverter will not connect to the grid if the measured resistance is smaller than 100kΩ.

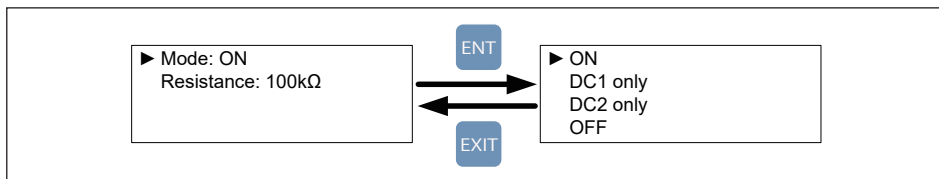

Figure 4-11: Insulation screen display

4.3.7.3 Grid Code

The grid code setting is used to program the inverter control system to be consistent with the grid voltage, frequency and basic grid configuration of the country or locale where installed. In NA, the grid code setting is IEEE 1547 480V.

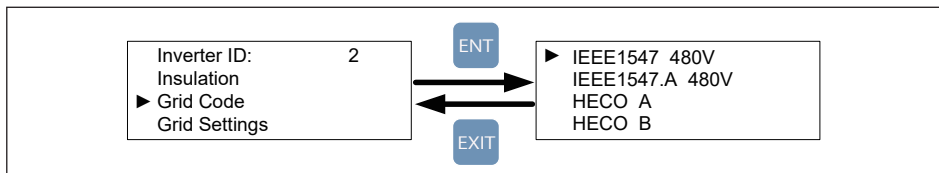

Figure 4-12: Grid Code screens

4.3.7.4 Grid Settings

This menu item allows the installer or an engineer to enable and/or adjust specific "smart inverter" (aka, CA Rule 21 or HECO functionality) grid parameters to include low/high voltage ride-through (L/HVRT), low/high frequency ride-through (L/HFRT), Soft start and ramp rates. Refer to **Figure 4-13**. Further details of this functionality is provided in Appendix A and B.

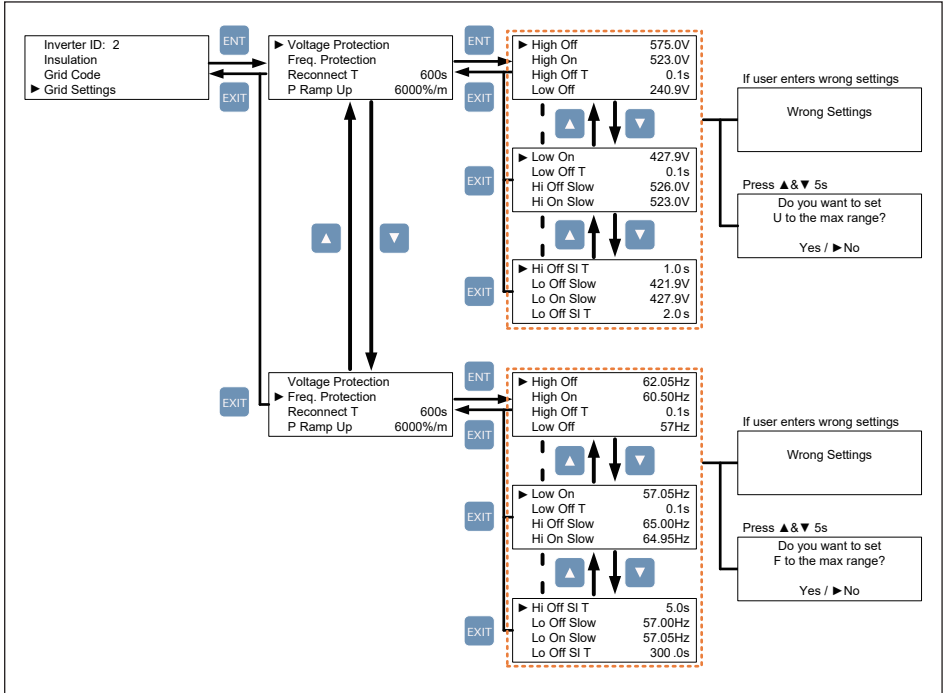

Figure 4-13: Grid Settings screens

4.3.7.5 Potential Induced Degradation

PID (Potential Induced Degradation) is a phenomenon which puts a high level negative voltage on PV module and make PV module performance low. The default action time of PID is set with 0(it means disable PID function), user can set the time from 0-10 Hours or Auto. It will be started the function at 30 minutes after No DC, and will be stop the function when DC voltage is input.

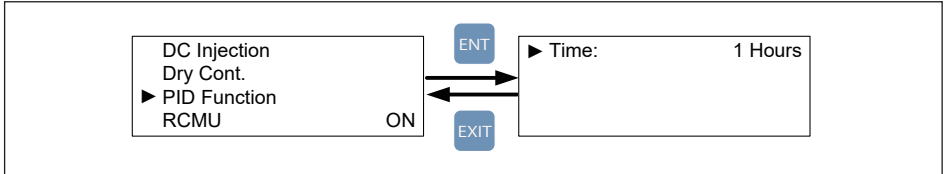

Figure 4-14: PID function Display screens

4.3.7.6 Residual Current Monitoring Unit (RCMU)

RCMU (Residual Current Monitoring Unit) monitors DC and AC residual current and inverter is disconnected from grid when residual current is high enough. The default setting of RCMU is “ON”.

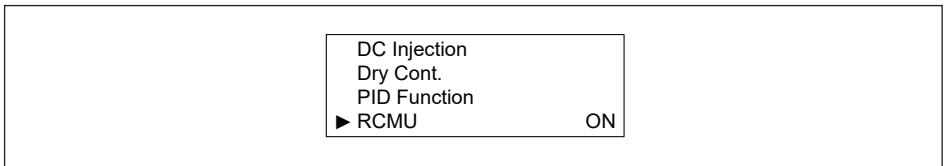

Figure 4-15: RCMU screen

4.3.7.7 Emergency Power-Off Enable

The inverter has an Emergency Power-Off function (EPO), which once enabled, can be used to turn off the inverter via an external control signal.

See **Section 3.5.3** for additional details.

4.3.7.8 AC Connection

The AC Connection sub-menu provides user a choice of AC connections:

- 3P3W - indicates the inverter connection to an AC grid is as a 3-phase/3-wire device (default setting) No Neutral is required.
- 3P4W - indicates the inverter connection to an AC grid is as a 3-phase/4-wire device; Neutral connection required.

EPO	Normal Close
▶ AC Connection	3P3W
Anti-islanding	ON
Max. Power	83000W

Figure 4-16: AC Connection

4.3.7.9 Anti-Islanding

Anti-islanding protection is a way for the inverter to sense when there is a problem with the power grid, such as a power outage, and shut itself off to stop feeding power back to the grid. Delta anti-islanding function is based on the Sandia Frequency Shift algorithm. The default setting depends on grid code (always ON in NA).

EPO	Normal Close
AC Connection	3P3W
▶ Anti-islanding	ON
Max. Power	83000W

Figure 4-17: Anti-Islanding Display screen

4.3.7.10 DC Arc Fault Circuit Interrupter (AFCI)

AFCI (Arc Fault Circuit Interrupter) is an advanced circuit breaker that breaks the circuit when it detects a dangerous electric arc in the circuit it protects to prevent electrical fires. The default setting of AFCI is “ON”.

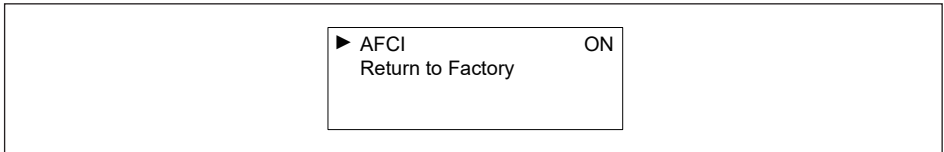

Figure 4-18: DC AFCI Display screen

4.3.7.11 Grid code confirm

User can confirm grid code parameters as following, such as voltage and frequency protection parameters.

More detail of F/VRT will be show in appendix.(For HECO and Rule 21).

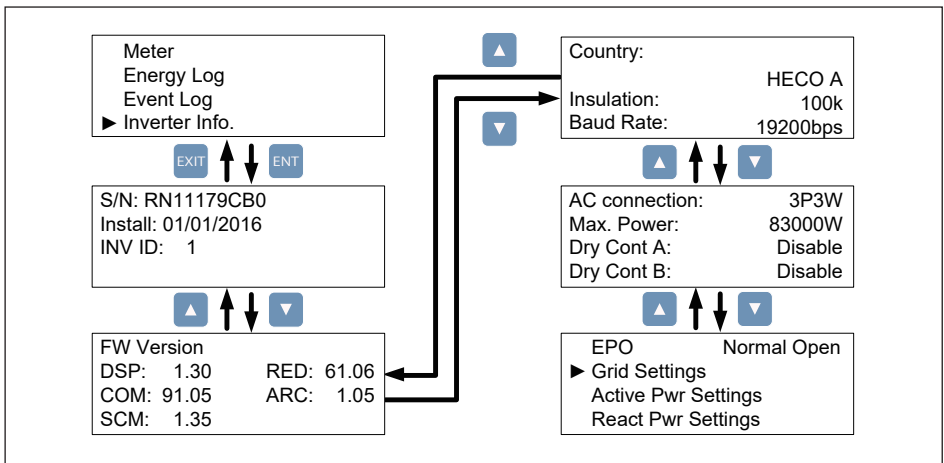

Figure 4-19: Grid Code Confirm screens

4.3.8 Active / Reactive power

A password is required to enter Active / Reactive Power page.

This page includes two kinds of function: active power control and reactive power control. In active power control function, there are 3 control modes:

Power Limit, Power vs. Frequency, and P(V). In reactive power control function, there are 4 control modes: Constant cosphi, cosphi(P), Constant Q, and Q(V). These modes will be introduced in next section.

- All function's voltage settings used by phase voltage. -

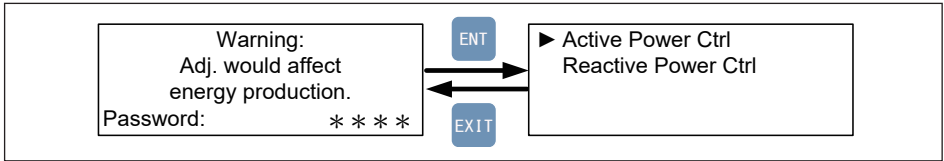

Figure 4-20: Active / Reactive power screens

4.3.8.1 Power Limit

This control mode can reduce the output power to a percentage of inverter's rated power. Users can limit the output power by set the Set Point in Power Limit page.

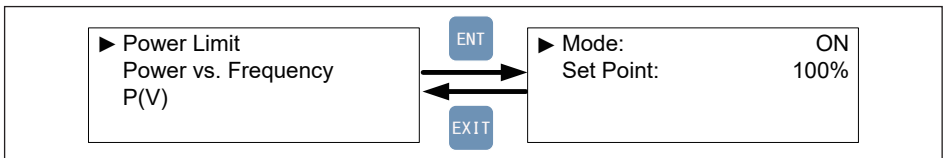

Figure 4-21: Power Limit screens

4.3.8.2 Power vs. Frequency

Inverter will reduce output power when grid frequency rises up if this mode enabled. Users can tune the parameters in Power vs. Frequency page to change the inverter's behavior.

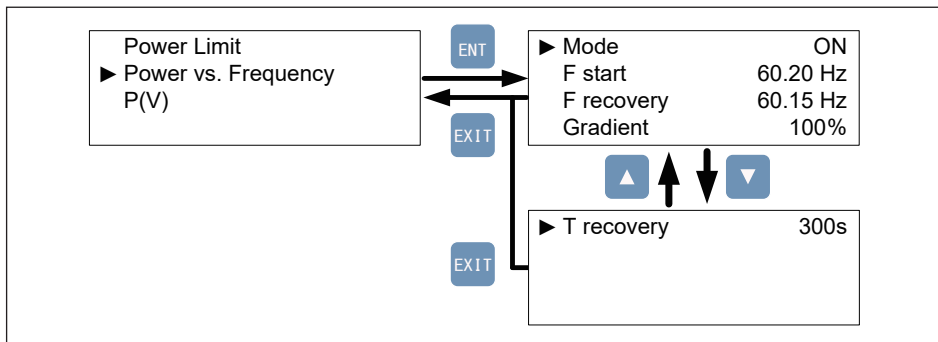

Figure 4-22: Power vs Frequency screens

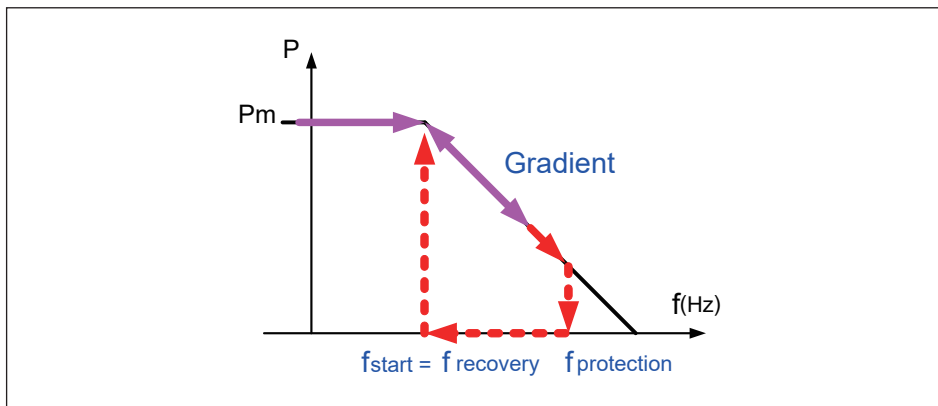

Figure 4-23: Power vs Frequency parameter

4.3.8.3 P(V)

When grid voltage rises up to a lock-in voltage(V lock-in) and inverter's present output power is greater than lock-in power(P lock-in), inverter will reduce the output power and keep it at a certain value(P lock-out) until grid voltage drop back to lock-out voltage(V lock-out) and passing a certain time(T recovery).

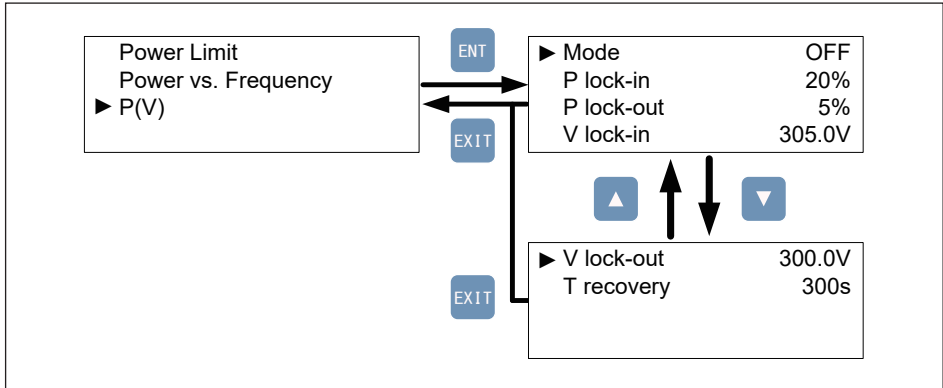

Figure 4-24: P(V) screens

4.3.8.4 Constant cosphi

Inverter can feed in a fixed reactive power to grid. Users can set the power factor(cosphi) in Constant cosphi page.

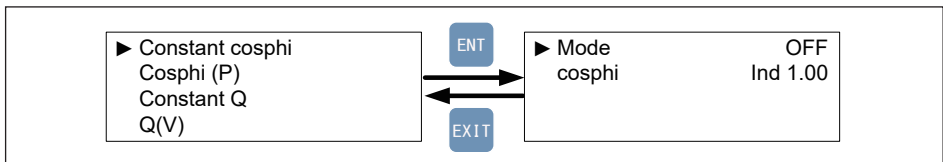

Figure 4-25: Constant cosphi screens

4.3.8.5 Cosphi (P)

Cosphi (P) is a function that inverter will feed in reactive power when its output active power reach the setting values.

When grid voltage reach the lock-in voltage(V lock-in), inverter will enable cosphi (P) function automatically and disabled it when grid voltage reach lock-out voltage(V lock-out).

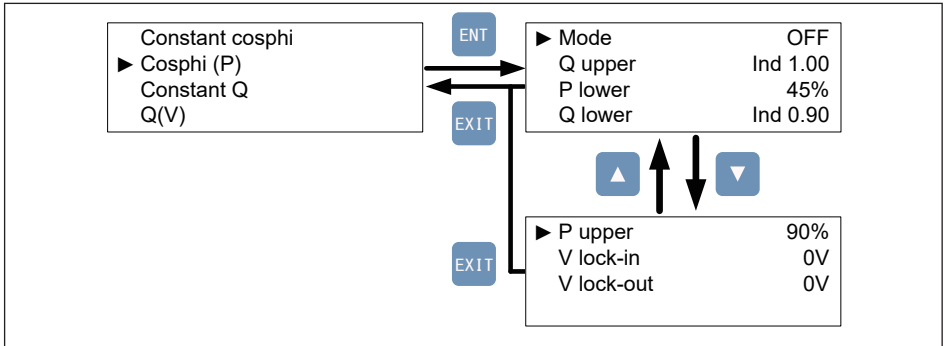

Figure 4-26: Cosphi (P) screens

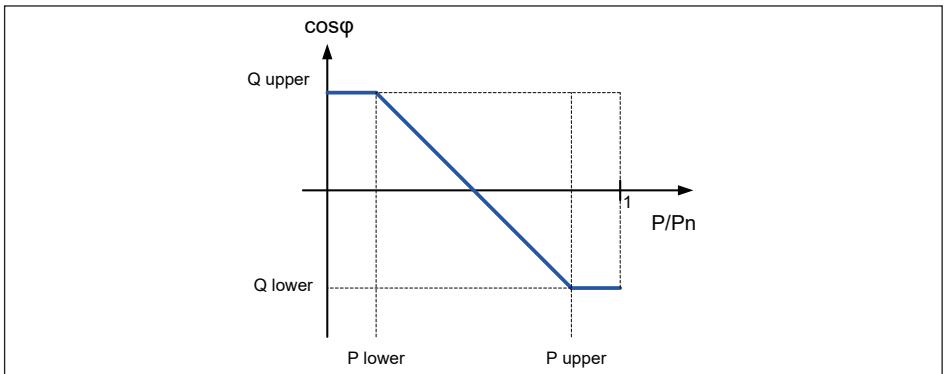

Figure 4-27: Cosphi (P) curve

4.3.8.6 Constant Q

Like Constant cosphi function, users can assign a percentage of reactive power in Constant Q page.

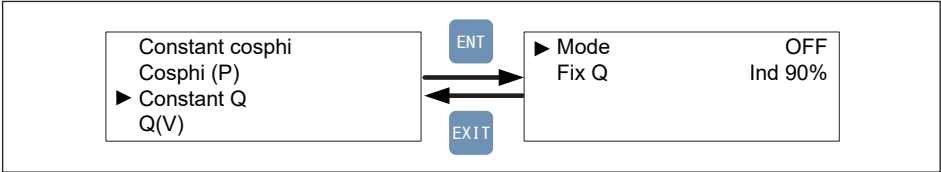

Figure 4-28: Constant Q screens

4.3.8.7 Q(V)

Q(V) is a control mode that inverter will provide reactive power according to grid voltage.

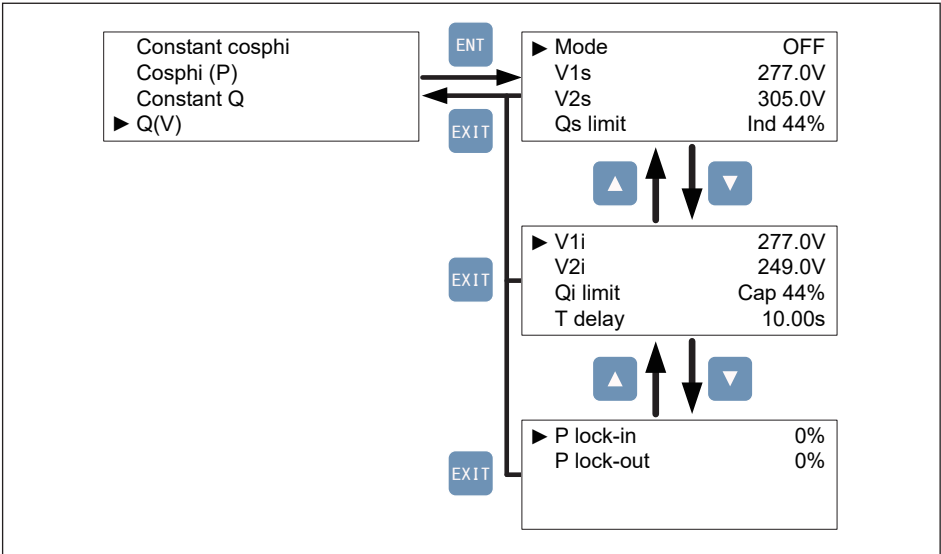

Figure 4-29: Q(V) screens

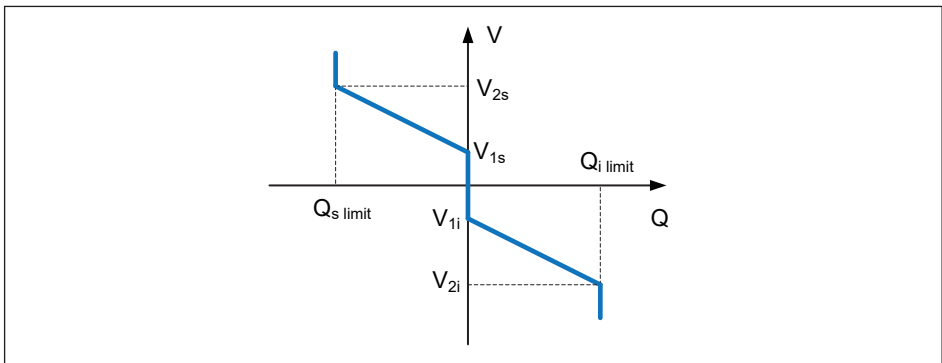

Figure 4-30: Q(V) parameter

4.3.9 FRT (Fault ride through)

Some area requests that inverter should keep connected to grid when grid voltage drops suddenly in few seconds. In these areas, users can enable FRT function and adjust the parameters to meet the requirement.

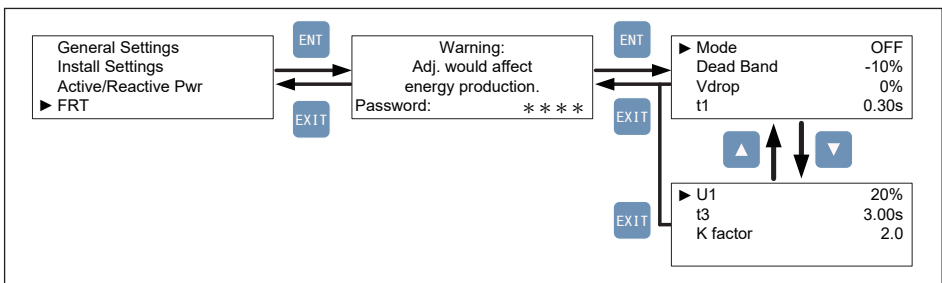

Figure 4-31: FRT screens

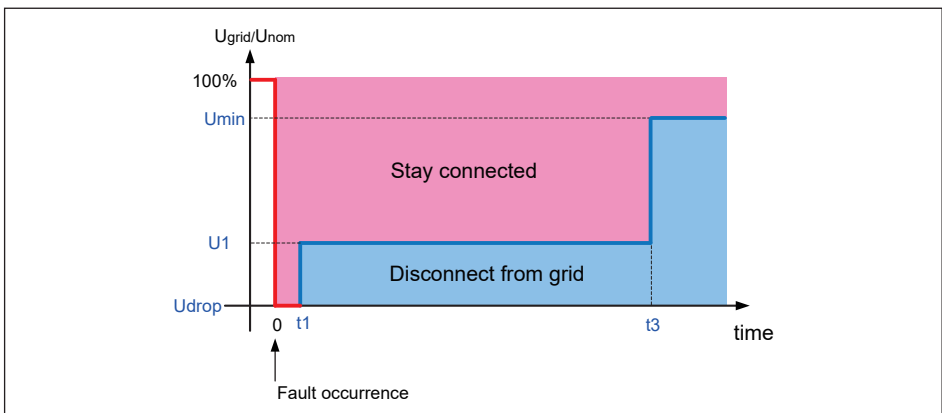

Figure 4-32: FRT Parameter

5 Maintenance

Please check the unit regularly. If there are any impaired or loose parts, please contact your solar installer. Ensure that there are no fallen objects in the path of the heat outlet.

WARNING !



- Prior to beginning any maintenance procedures switch AC and DC power off to avoid risk of electrical shock!

5.1 Removing and re-installing the Wiring Box (WB) cover

In order to guarantee proper long-term operation of the inverter, the following procedures must be followed used to remove and re-install the WB cover, Refer to *Figure 5-1*.

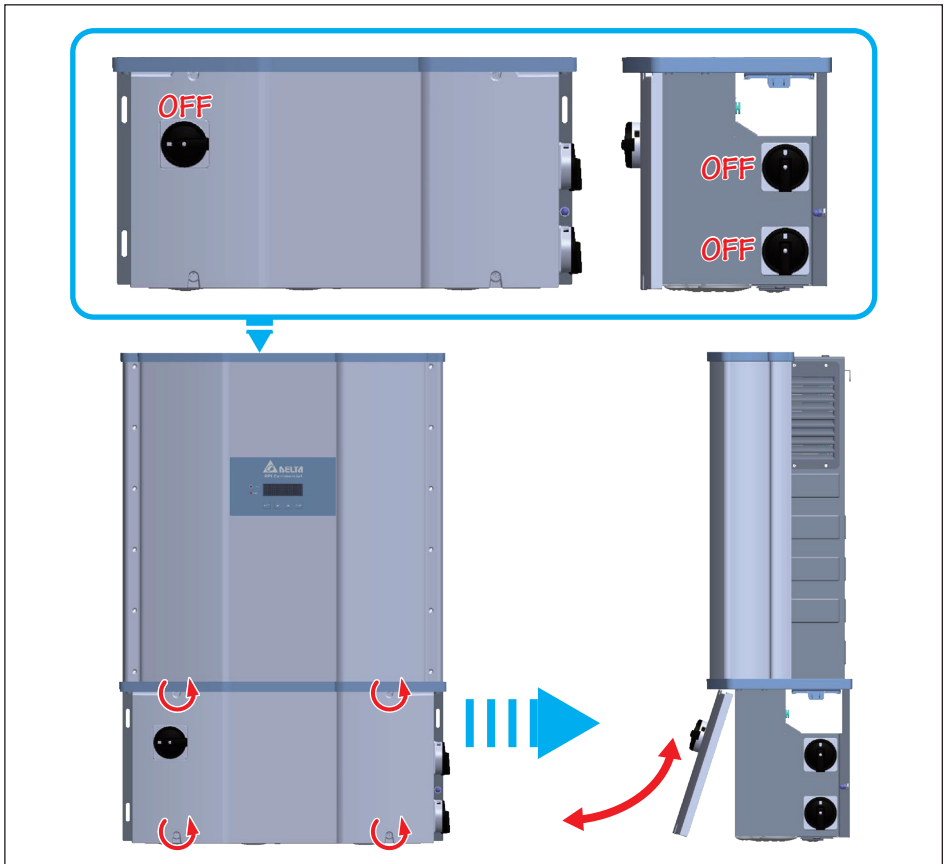

Figure 5-1: Removing and reinstalling the WB cover

ATTENTION



- Use Hexagon screw driver or other proper tool to untighten WB cover screws.
- WB cover screws are captive screw type. Do not disassemble cover screws.

5.1.1 Removing the WB cover

- Never attempt to remove the WB cover in rainy damp weather without weather protection around the inverter.
 - Switch AC and DC power off and wait until LCD display turns off.
 - Ensure WB cover is clean before removing.
 - Loosen the 4 screws on the WB front cover and remove cover.
 - Use care not to contaminate the WB cover gasket and mating surfaces
- After removing the WB cover, do not leave the WB uncovered for long periods of time.**

5.1.2 Re-installing the WB cover

Before re-installing the wiring box (WB) cover:

1. Ensure mating surfaces and gasket are clean
2. The gasket is properly located and aligned in its mounting slot.

When re-installing the wiring box cover:

1. The screws of WB cover are aligned when holding WB cover by hand.
2. Hand tighten screws cross wise and equally.
3. Fully tighten the WB cover screws to 21 in-lb of torque (2.37 N·m)

After re-installing the wiring box (WB) cover:

1. Use care to ensure the WB cover screws are started properly and not cross-threaded.
2. After tightening, check that screw heads are flush with cover

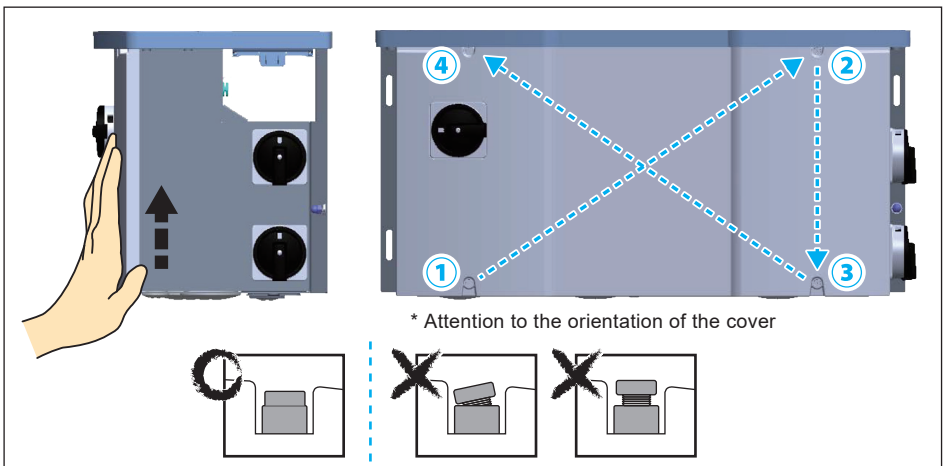
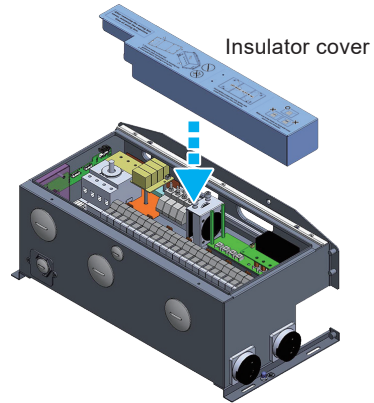
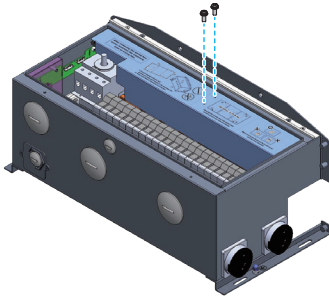

Figure 5-2: Re-installing process for Wiring Box cover

WARNING !

If it's necessary to remove the insulator cover of wiring box during Cabling or maintenance, the insulator cover must be put back in to the wiring box before re-install the cover, refer the figure.

* Screw torque required for assembling:
7 lbf-in (0.8 N·m)



5.2 Replacement of Surge Protection Devices (SPD)

M80/60 series models have the surge protection device (SPD) at both AC and DC side as shown in **Figure 5-3**. **Table 5-1** summarizes the specifications of AC and DC SPD.

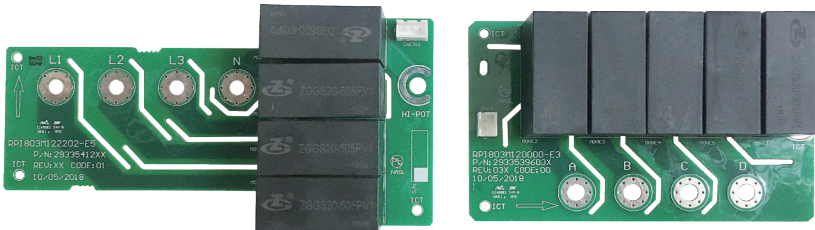

Figure 5-3: AC and DC SPD modules

Description		Value
Working voltage:	AC Module	895VRMS
	DC Module	1175VDC
Working Current (8/20us)		10kA
Rated Current (IMAX – 8/20us)		20kA
Operating Ambient Temperature Range		-40°C to 85°C
Manufacturer:	Sichuan Zhongguang Lightning Protection Technologies Co., Ltd	

Table 5-1: SPD Specifications

Surge protection devices (SPD) are designed to protect sensitive circuit elements of the inverter from damage caused by lightning and other electrical transients/surges, as such they are sacrificial components and periodically, may need replacement.

The SPDs are located in the inverter wiring box (WB) on both AC and DC input terminals. If a warning message “AC Surge” or “DC Surge” appears on display panel, follow the procedure below to replace the SPD.

- Determine which SPD unit is damaged. See **Figure 5-4**.

AC SPD: “AC Surge” with show on the corner of the LCD panel.

DC SPD: “DC Surge” with show on the corner of the LCD panel.



Figure 5-4: Display Indicating AC and DC SPD failure

- Accessing the Wiring Box
 1. Switch AC and DC power off and wait until LCD display turns off.
 2. **To access the wiring box, use procedure found in Section 5.1.1**
Do not leave the WB uncovered for long periods of time.

- Changing the SPD modules - use the following procedure:

The AC and DC SPD units are located as shown in **Figure 5-5**.

- To remove the defective SPD, refer to **Figure 5-6**
 1. Disengage the white wiring connector from the SPD PCB (3-pin on AC SPD or the 2-pin on DC SPD).
 2. Remove four Phillips head screws at the front (terminal block) side of the SPD PCB.
 3. Remove the single Phillips head screw located on the left (DC) or right (AC) side of the SPD PCB.
 4. Lift and remove the entire SPD PCB and replace with new unit.
 5. Install the new SPD using the above procedure in reverse order. Tighten the five screws to a torque value of 15 lbf-in (1.7 N·m).

- Re-installing the Wiring Box cover

To re-install the WB cover, use the procedure found in Section 5.1.2

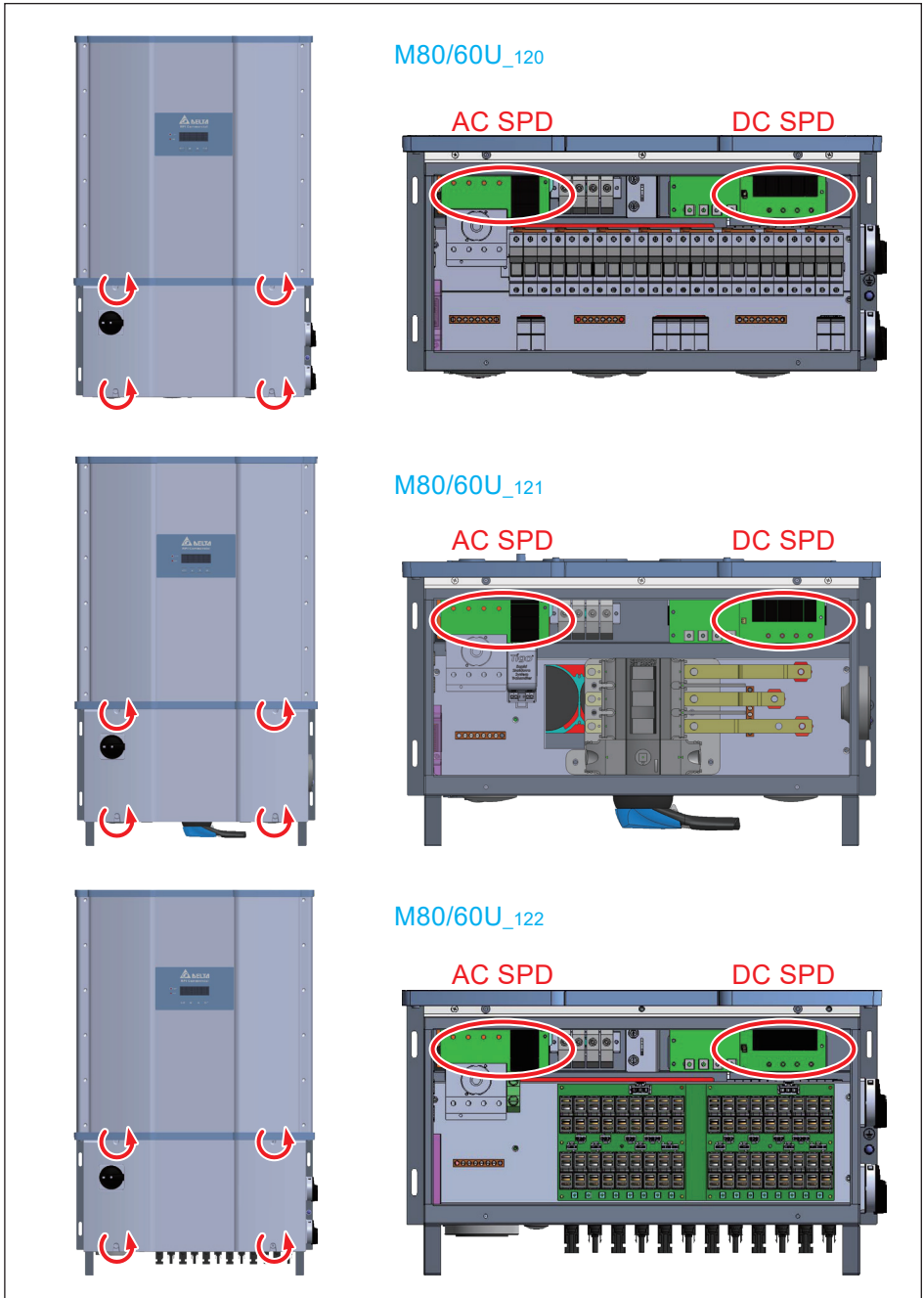

Figure 5-5: Location of SPD modules inside various WB versions

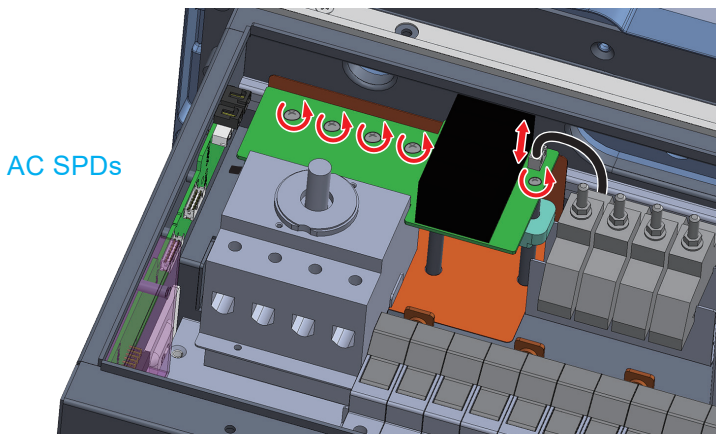
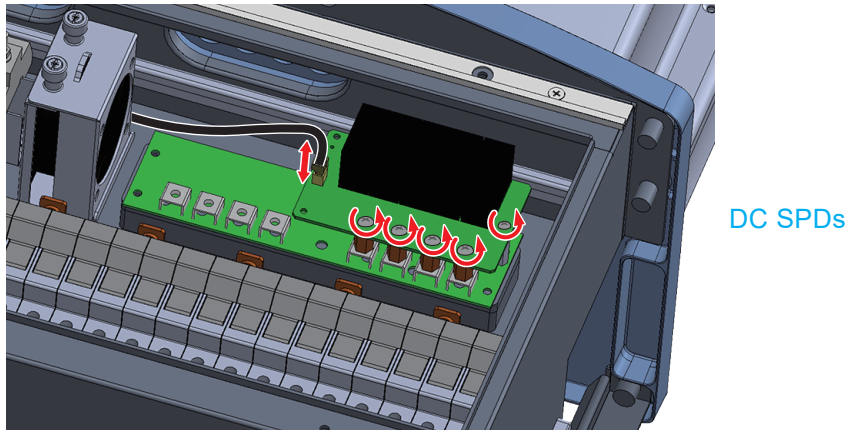

Figure 5-6: Remove screws as indicated unplug connectors

5.3 Replace Internal String Fuse

M80/60U_120 and M80/60U_122 models both have a wiring box provisioned with two independent internal string combiners, each associated with one of the two MPPT inputs.

The combiners utilize standard 10 mm x 38 mm PV combiner fuses and associated fuse holders. Because of the TL design, all strings are floating with respect to ground, and two fuses are required per string input connected in series with the positive and negative string leads.

Any 10mm x 38mm Listed PV fuse can be utilized for replacement purposes. The specifications of the required fuse and the fuse brand utilized at the factory are listed below.

Rated current	15 A	UL Listed	UL248-19/UL2579
Rated voltage	1000 V	UL Listing Category	JFGA
Operating Class	Solar PV	Typical Mfr	Littelfuse
Fuse Type	10x38 ferrule	Mfr P/N	OSPF015

Table 5-2: Combiner Fuse Specification

CAUTION – Shock/Fire hazard



Fuse holders do not have load break capability!
 Before opening any combiner fuse holder in -120 or -122 models be sure both DC switches are in the OFF position

The **M80/60U_120** wiring box is equipped with 32 DINrail mounted combiner fuses, which support connection of up to 16 strings (eight/MPPT). The fuses are carried within Dead Front Fuse Holders (see **Figure 5-7**), which are designed to be "Finger Safe", i.e., opening a fuse holder disconnects the fuse at both ends, allowing safe removal by hand.

The fuse holders also feature a "blown fuse" LED indicator that provides the user a visual indication of any open fuses. This design provides optimum safety to personnel who replace the string fuses. **Figure 5-8** shows the detail for removing/re-installing string fuses for this model. Refer to **Figure 2-5** for additional information.



Blown fuse LED Indicator

Figure 5-7: Fuse Board (PWB) and fuse holder locations for M80/60U_120

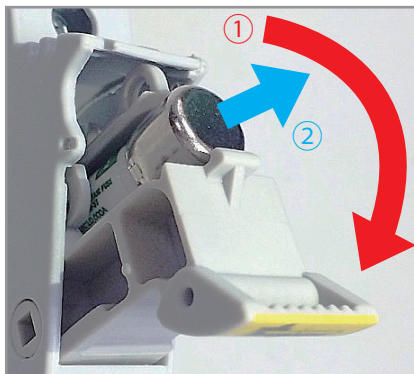

Finger-safe fuse holder

Figure 5-8: Finger-safe fuse holder with blown fuse indicator shown

Fuse replacement Procedure

Check the combiner fuses if the power generation of inverter is abnormal.

1. Switch AC and DC power off and wait until LCD display turns off
2. To access the wiring box, use procedure found in **Section 5.1.1**

Use caution: Though the DC switches are off, the fuse holders are energized by the PV array.

3. Pull out the fuse holder door and check the fuse. (**Figure 5-9**)
4. Check fuse continuity and replace the fuse if necessary.
5. Re-install the WB cover, use the procedure found in **Section 5.1.2**

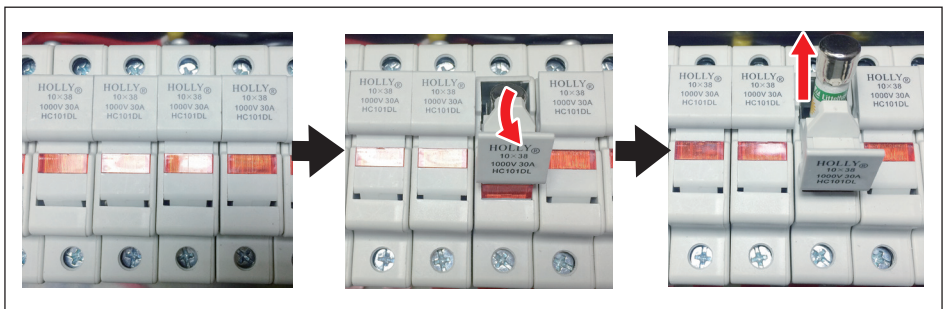

Figure 5-9: Finger-safe fuse holders and fuse access for -120 models

ATTENTION



- Use caution when removing/inserting fuses as high voltage DC from the array is present at the fuseholder even when the DC switch is disconnected.

The **M80/60U₋₁₂₂** wiring box is equipped with 36 combiner fuse holders, which support connection of up to 18 strings (9/MPPT). The fuse holders are mounted on two separate PWBs (one/MPPT). The pull-out fuse holders allow safe removal of fuses which are inserted into a carrier.

Figure 5-10 shows the location of the combiner fuse holders, and **Figure 5-11** provides details to remove a fuse from the -122 WB; refer to **Figure 2-5** for additional information.

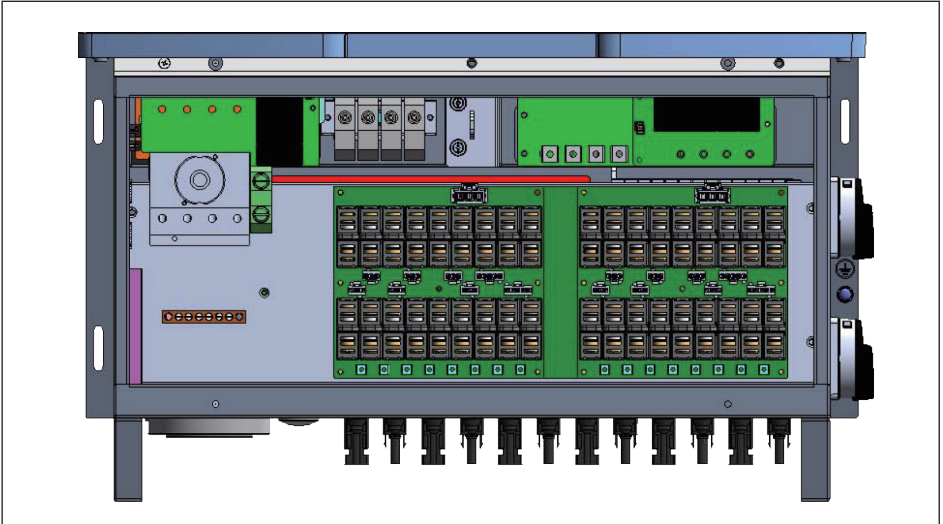

Figure 5-10: Fuse holder locations for M80/60U₋₁₂₂

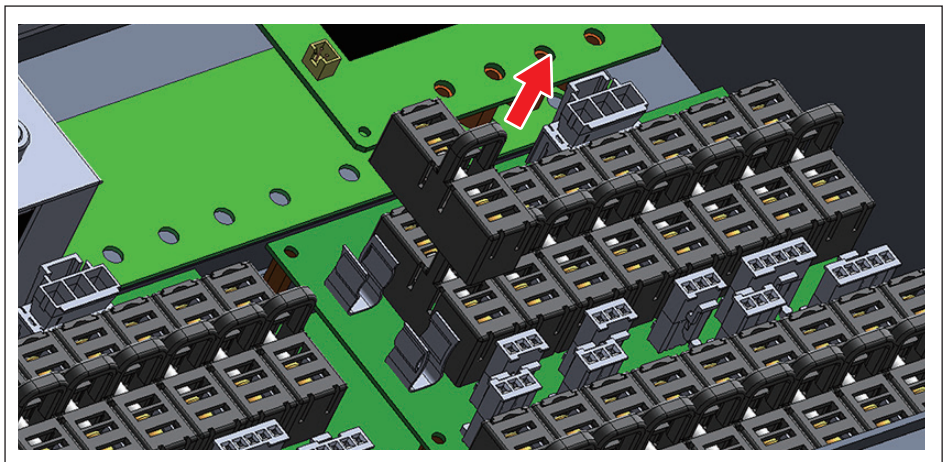

Figure 5-11: Accessing the individual fuses for M80/60U₋₁₂₂

Check the combiner fuses if the power generation of inverter is abnormal using the following procedure:

1. Check “Power meter/string monitoring” page on the LCD display, to determine if any string current measurement is zero, which will most probably indicate a blown fuse. (**Figure 5-12**)
2. Switch AC and DC power off and wait until LCD display turns off.
3. **To access the wiring box, use procedure found in Section 5.1.1**
4. Based on step 1, check the corresponding fuse locations by pulling out the fuse holder (**Figure 5-11**) and checking continuity of the fuse.
5. Replace the fuse if necessary.
6. **Re-install the WB cover, using the procedure found in Section 5.1.2**

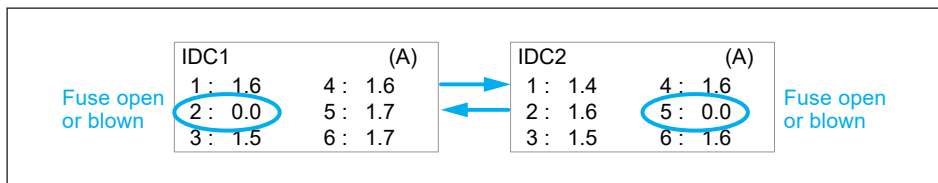

Figure 5-12: String monitor

5.4 Smart Fans Replacement and Filter Cleaning

M80/60 models are provisioned with processor-controlled "smart fans" for cooling of the electronics. This section provides procedures for cleaning filters associated with these fans, and instructions for field replacement of the fans. The fans utilized have high reliability ratings and coupled with use of processor controls provide a "smart" cooling system design with a long life. The system features tachometer detection of a failed fan, and generates a "FAN-FAIL" signal that is interfaced to the inverter control to trigger a FAN-FAIL alarm and places the inverter in a power de-rate mode as required for safe operation.

Depending upon the model, fans are installed at two locations within inverter:

- Wiring Box (WB) compartment (-120, -122)
- Power Module (PM) compartment (-120, -121, -122)

Figures 5-13, 5-14, 5-15 illustrates the fan locations.

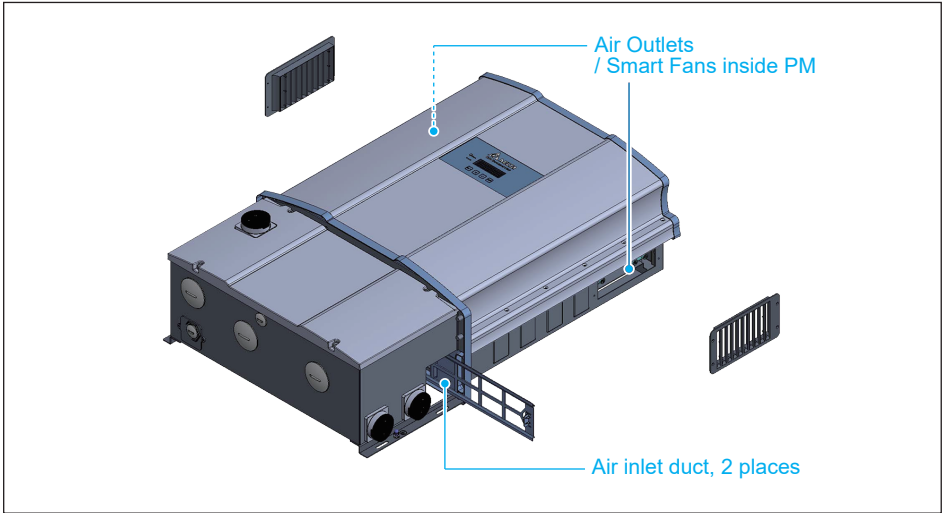

Figure 5-13: Smart Fans location on Power Module chassis

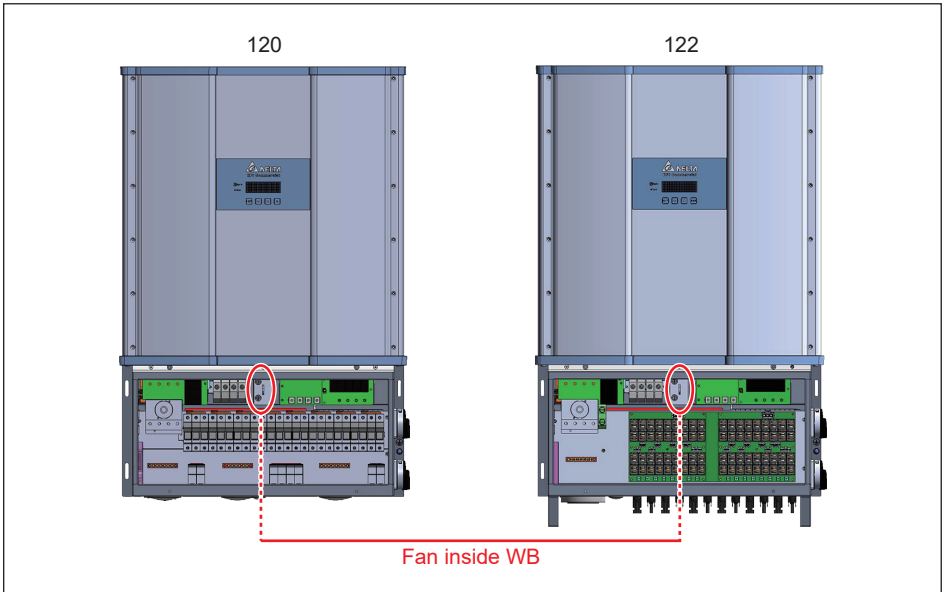

Figure 5-14: Smart Fan locations inside WB chassis

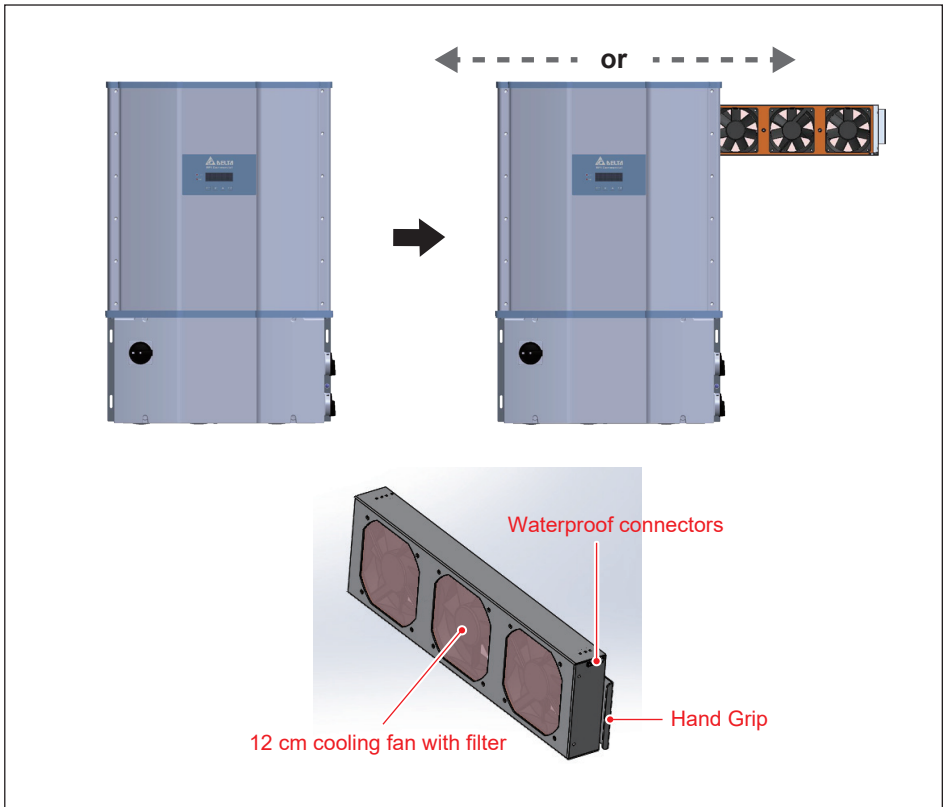

Figure 5-15: Power Module Fan tray

ATTENTION



- Periodic fan and filter cleaning is required to insure long life and reliability.
- The time period between cleanings depends on the quality of the environment.
 - Under normal duty use, Delta recommends smart fans and filters be cleaned every 6 months
 - For very dusty locations, it may be necessary to clean the fans and filters quarterly or monthly.

The cooling fans feature modular designs that make their removal for cleaning or replacement a simple task. As a result, the replacement of fans is also smart.

5.4.1 Wiring Box (WB) compartment fan

When used, the WB compartment is provisioned with a single fan module.
(See **Figure 5-14, 5-16**).

Procedure to remove WB Compartment Fan

- (1) To access Remove the two thumb screws shown in **Figure 5-16** and store outside the fan cabinet.
- (2) Disconnect the fan power connector (yellow body shown in **Figure 5-16**) located at the right front of the fan cover.
- (3) Lift the entire fan assembly from the WB.
- (4) Clean assembly or replace with a new fan.
- (5) Reassemble using a tightening torque of 8.85 lbf-in (1 N·m)

* Screw torque required for assembling: 8.85 lbf-in (1 N·m)

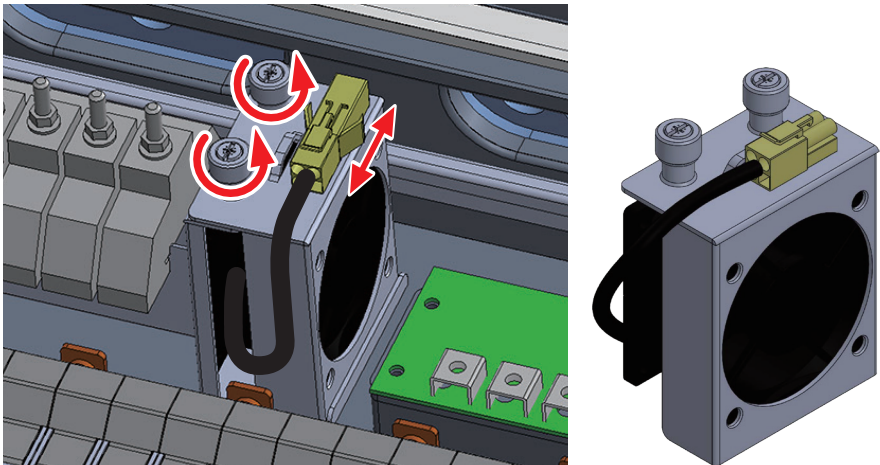

Figure 5-16: Procedure for Removing WB fan assembly

5.4.2 Power Module (PM) Fan Tray

The inverter electronics are convection cooled. The primary equipment used for this function consists of a fan tray located in a plenum within the inverter power module. The PM electronics are isolated, and heat is transferred to the plenum airflow via a large heatsink.

The PM fan tray is modular and holds three smart fans that that operate together and also provide redundancy; the inverter will operate to full power with two fans operating and will enter a power derating mode under failure of a second fan. These fans are protected by air filters at the plenum air inlet and outlet.

5.4.2.1 PM Fan Tray removal procedure

Refer to **Figure 5-17** and follow the steps outlined below:

1. Remove the outlet filter assemblies on the left and right side of the PM by removing four screws on each. If filter maintenance is the goal, the two filter elements can be cleaned at this time and reassembled.
2. On the right side, unplug the fan power wiring from their terminals.
3. On the right side, loosen the four knurled screws and remove the two screw assemblies.
4. Grasp the handle at the top of the fan tray and pull straight out from PM chassis.

To reassemble reverse the order of the above procedure and tighten screws to torque values indicated in **Figure 5-17**.

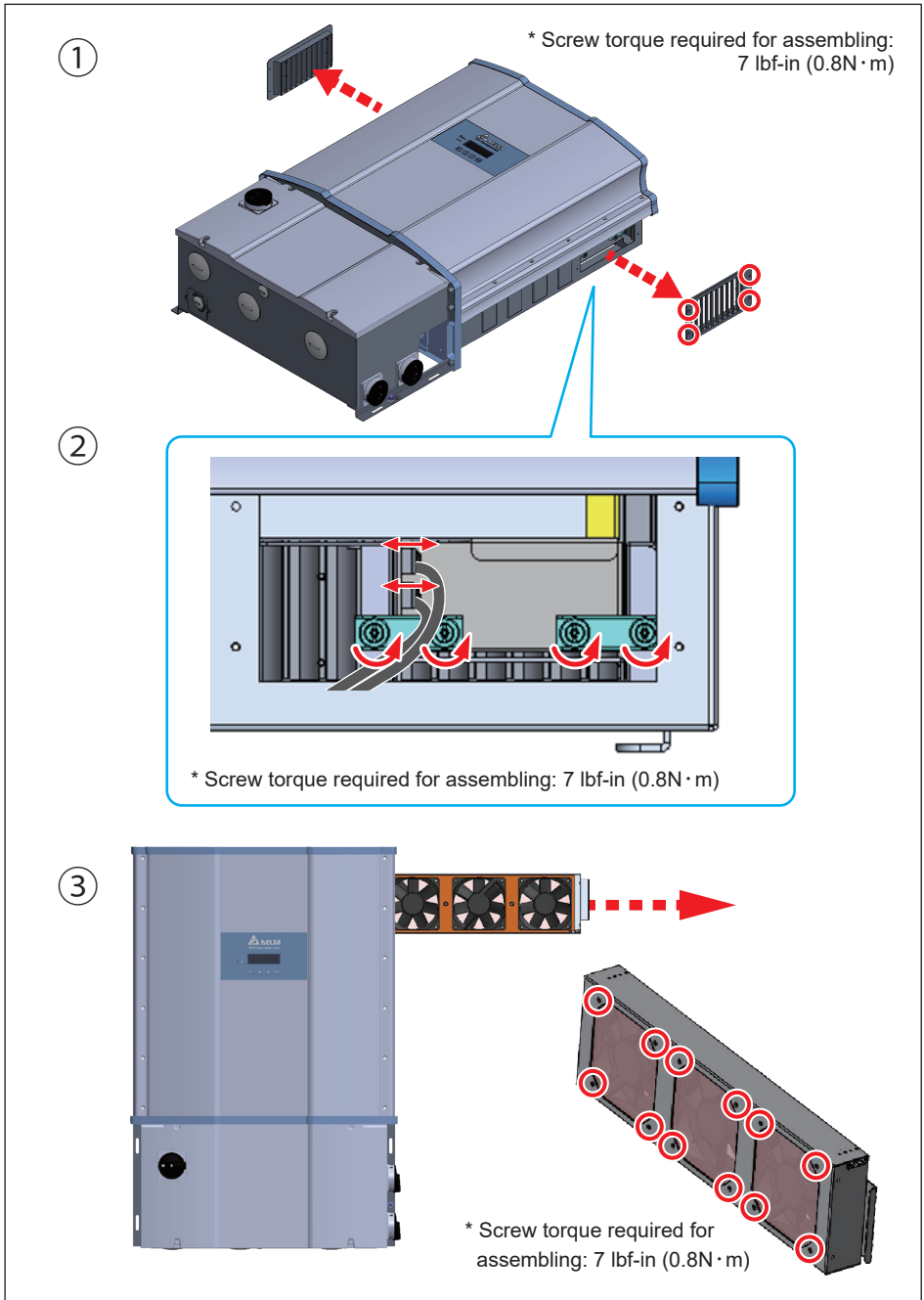

Figure 5-17: Disassembling fan tray from PM chassis (showing one side only)

5.4.2.2 Procedures to remove PM air inlet filter

Refer to **Figure 5-18**. Filter can be removed from either side of PM:

1. Unlatch the retaining hook and grasp the filter handle.
2. Carefully pull the filter frame straight out keeping it perpendicular to the side of the PM chassis.
3. Clean the filter with warm water and allow to dry.

Reverse the above procedure to re-install the filter. When filter assembly is in proper position, the retaining hook should be latched to the rail.

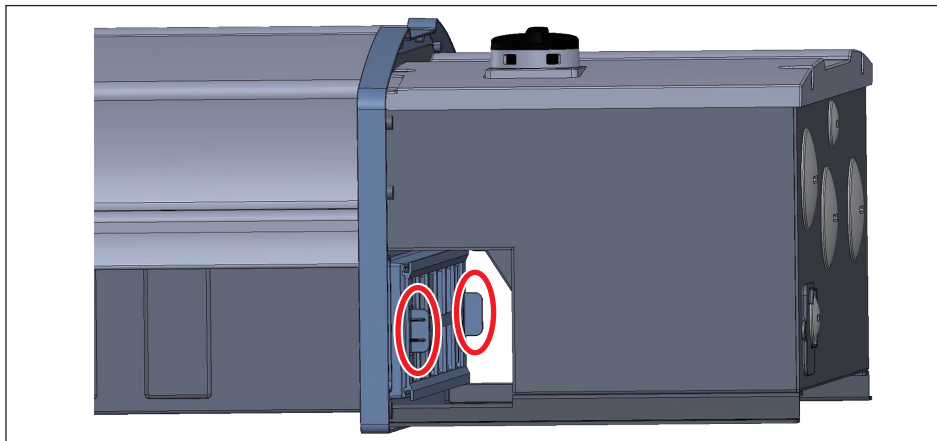

Figure 5-18: Removing the PM air inlet filter

5.5 Release AFCI Fault Protection

When AFCI (Arc Fault Circuit interrupter) detects an arcing energy on PV wiring, the inverter will stop operating and be locked for fire hazards and safety concerns.

AFCI Fault protection releasing procedure

1. Check DC wiring to find and replace damaged wires which cause arcing energy.
2. Press "▼" and "▲" button on the display together for 5 seconds to release AFCI Fault protection.

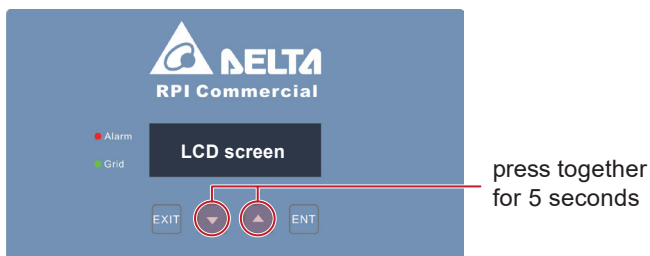

5.6 De-Commissioning

When necessary to remove the inverter from active operation for maintenance or replacement, follow the instructions below.

DANGER : ELECTRICAL HARZARD!!



To avoid serious injury, use follow the procedure

- Switch off internal AC switch and then both DC switches to cease inverter operation
- Switch off external AC circuit breaker or switch to disconnect the electrical grid from the inverter chassis
- Remove array DC from chassis requires opening string level MC4 connectors in order to break string continuity at the inverter MC4 connectors are not intended for use as a load break switch, therefore:

Ensure inverter DC switches are open and there is no DC current flow

- For -122 model –
 - Use MC4 tool to open and disconnect each string from the chassis mounted MC4 terminals at the inverter
- For -120 model –
 1. Within the connected array, open an MC4 connector within each string connected to the inverter; repeat for strings connected to each MPPT input
 2. Open WB by removing WB cover
 3. For each MPPT channel,
 - Use a voltmeter to check for zero voltage at the combiner output
 - If any hazardous voltage level is detected, use voltmeter at the combiner input (fuse holders) to measure voltage across each string.
 - For any strings showing hazardous voltage, open external MC4 connectors in those strings.
 - Repeat measurements to insure there is no continuity in any connected string
 - Loosen fuse holder screws to free string wiring and remove from wiring box
- For -121 model –
 1. For each MPPT channel
 - Locate and open DC disconnect switch located at or within the associated array combiner;
 - if no switch is provisioned, open continuity of each string as described for -120 model, above
 - Open inverter WB, and measure voltage across each MPPT input terminal pair
 - Confirm there is no hazardous DC voltage at either input
 2. Loosen fuse holder screws to free string wiring and remove from wiring box
- RS-485 Communication module – all models
 1. Remove communications module from inverter
 2. Disconnect all communications wiring from the module terminals
 3. Remove wiring from communications board assembly
 4. Re-install communications board assembly in inverter

CAUTION : HOT SURFACES, DO NOT TOUCH !



- Use care not to touch hot surfaces if the inverter is just shutting down.
- Do not perform any task until the product cool down sufficiently.

CAUTION : POSSIBLE INJURY !



The inverter weighs more than 84 kg (185 lb).

There is risk of injury if the inverter is carried incorrectly or dropped during transport or when attaching or removing it from the wall mounting bracket.

Personnel should wear suitable gloves to protect against injury and maintain firm control of the inverter chassis

ATTENTION



Use care when handling mounting hardware

Do not leave loose screws and nuts inside the wiring box compartment.

6 Error message and Trouble Shooting

While Delta Electronics endeavors to build electronic products to very high standards of reliability, there will arise instances where the inverter may not operate properly. When such a condition is encountered, please follow the instructions in the Troubleshooting Guide (**Tables 6-1, 6-2, and 6-3**) to attempt to clear the fault.

If fault continues to appear or if it is listed more than once in the inverter Error log, it may be necessary to call Delta Technical Service Hot Line. A service call checklist with necessary information for a call to the hotline is provided at the end of the Troubleshooting guide.

Delta Technical Hotline can be reached at 1-877-440-5851 or 1-626-369-8021

6.1 Error Codes

Table 6-1A: Error Codes and Messages

Message	Possible cause	Action
AC Freq High (E01)	<ol style="list-style-type: none"> Actual utility frequency is over the OFR setting Incorrect Grid code setting Detection circuit malfunction 	<ol style="list-style-type: none"> Check the utility frequency Check Grid code setting Contact customer service for technical support
AC Freq Low (E02)	<ol style="list-style-type: none"> Actual utility frequency is under the UFR setting Incorrect Grid code or Grid setting Detection circuit malfunction 	<ol style="list-style-type: none"> Check the utility frequency Check Grid code & Grid setting Contact customer service for technical support
Grid Quality (E07)	Non-linear load in Grid and near to inverter	Grid connection of inverter need to be far away from non-linear load if necessary
AC Con. Fail (E08)	<ol style="list-style-type: none"> Wrong connection in AC terminal Detection circuit malfunction 	<ol style="list-style-type: none"> Check the AC connection in accordance with the user manual Contact customer service for technical support
No Grid (E09)	<ol style="list-style-type: none"> AC breaker is OFF Disconnect in AC terminal 	<ol style="list-style-type: none"> Switch on AC breaker Check the connection in AC terminal and make sure it connects to inverter
AC Volt Low (E10, E15, E20)	<ol style="list-style-type: none"> Actual utility voltage is under the UVR setting Incorrect Grid code or Grid setting Wrong connections in AC terminal Detection circuit malfunction 	<ol style="list-style-type: none"> Check the utility voltage within the suitable range Check Grid code & Grid setting Check the connection in AC terminal Contact customer service for technical support
AC Volt High (E11, E13, E16, E18, E21, E23)	<ol style="list-style-type: none"> Actual utility voltage is over the OVR setting Utility voltage is over the Slow OVR setting during operation Incorrect Grid code or Grid setting Detection circuit malfunction Wrong connection in AC terminal 	<ol style="list-style-type: none"> Check the utility voltage within the suitable range Check Grid code & Grid setting Check the connection in AC terminal Contact customer service for technical support
Solar1 High (E30)	<ol style="list-style-type: none"> MPPT 1 input voltage is over 1000Vdc Detection circuit malfunction 	<ol style="list-style-type: none"> Modify the solar array setting, and make the Voc less than 1000Vdc Contact customer service for technical support

Table 6-1B: Error Codes and Messages

Message	Possible cause	Action
Solar2 High (E31)	<ol style="list-style-type: none"> 1. MPPT 2 input voltage is over 1000Vdc 2. Detection circuit malfunction 	<ol style="list-style-type: none"> 1. Modify the solar array setting, and make the Voc less than 1000Vdc 2. Contact customer service for technical support
Insulation (E34)	<ol style="list-style-type: none"> 1. PV array insulation fault 2. Large PV array capacitance between Plus to Ground or Minus to Ground or both. 3. Detection circuit malfunction 	<ol style="list-style-type: none"> 1. Check the insulation of Solar inputs 2. Check the capacitance, dry PV panel if necessary 3. Contact customer service for technical support

6.2 Warning Codes

Table 6-2A: Warning Codes and Messages

Message	Possible cause	Action
Solar1 Low (W01)	<ol style="list-style-type: none"> 1. MPPT 1 input voltage is under the limit 2. Some devices were damaged inside the inverter if the actual MPPT 1 voltage is close to "0" 3. Detection circuit malfunction 	<ol style="list-style-type: none"> 1. Check the MPPT 1 voltage connection to the inverter terminal 2. Check all switching devices in boost1 3. Contact customer service for technical support
Solar2 Low (W02)	<ol style="list-style-type: none"> 1. MPPT2 input voltage is under the limit 2. Some devices were damaged inside the inverter if the actual MPPT 2 voltage is close to "0" 3. Detection circuit malfunction 	<ol style="list-style-type: none"> 1. Check the MPPT 2 input voltage to the inverter terminal 2. Check all switching devices in boost2 3. Contact customer service for technical support
WB Fan Fail Int Fan Fail Ext Fan Fail (W11)	<ol style="list-style-type: none"> 1. One or more fans are locked 2. One or more fans are defective 3. One ore more fans are disconnected 4. Detection circuit malfunction 	<p>Ext Fan Fail</p> <ol style="list-style-type: none"> 1. Remove the object that stuck in the fan(s) 2. Replace the defective fan(s) 3. Check the connections of all fans 4. Contact customer service for technical support <hr style="border-top: 1px dashed black;"/> <p>Int Fan Fail & WB Fan Fail Contact customer service for technical support</p>
AC Surge DC Surge	<ol style="list-style-type: none"> 1. Inverter was struck by lightning. 2. One or more SPD are defective 3. One or more SPD are disconnected 4. Detection circuit malfunction 5. Wrong connection in AC terminal 	<ol style="list-style-type: none"> 1. Check inverter's status 2. Replace the defective SPD 3. Check the connections of SPDs 4. Check the connection in AC terminal 5. Contact customer service for technical support

6.3 Fault Codes

Table 6-3A: Fault Codes & Messages

Message	Possible cause	Action
DC Injection (F01, F02, F03)	<ol style="list-style-type: none"> Utility waveform is abnormal Detection circuit malfunction 	<ol style="list-style-type: none"> Check the utility waveform. Grid connection of inverter need to be far away from non-linear load if necessary Contact customer service for technical support
Temperature (F05)	<ol style="list-style-type: none"> The ambient air is over 60°C (The installation is abnormal) Detection circuit malfunction 	<ol style="list-style-type: none"> Check the installation ambient and environment Contact customer service for technical support
Temperature (F07)	<ol style="list-style-type: none"> Ambient air is less than -30°C Detection circuit malfunction 	<ol style="list-style-type: none"> Check the installation ambient and environment Contact customer service for technical support
HW NTC1 Fail (F06)	<ol style="list-style-type: none"> Ambient temperature >90 °C or <-30 °C Detection circuit malfunction 	<ol style="list-style-type: none"> Check the installation ambient and environment Contact customer service for technical support
HW NTC2 Fail (F08)	<ol style="list-style-type: none"> Ambient temperature >90 °C or <-30 °C Detection circuit malfunction 	<ol style="list-style-type: none"> Check the installation ambient and environment Contact customer service for technical support
HW NTC3 Fail (F09)	<ol style="list-style-type: none"> Ambient temperature >90 °C or <-30 °C Detection circuit malfunction 	<ol style="list-style-type: none"> Check the installation ambient and environment Contact customer service for technical support
HW NTC4 Fail (F10)	<ol style="list-style-type: none"> Ambient temperature >90 °C or <-30 °C Detection circuit malfunction 	<ol style="list-style-type: none"> Check the installation ambient and environment Contact customer service for technical support
HW RLY (F13)	<ol style="list-style-type: none"> Driver circuit for relay is defective Relay(s) is defective Detection circuit malfunction (Inverter voltage) 	<ol style="list-style-type: none"> Check the input voltage, must >150Vdc Replace the defective relay Contact customer service for technical support
HW DSP ADC1 (F15)	<ol style="list-style-type: none"> Insufficient input power Auxiliary power circuitry malfunction Detection circuit malfunction 	<ol style="list-style-type: none"> Check the input voltage, must >150Vdc Check the auxiliary circuitry inside the inverter Contact customer service for technical support

Table 6-3B: Fault Codes & Messages

Message	Possible cause	Action
HW DSP ADC2 (F16)	<ol style="list-style-type: none"> 1. Insufficient input power 2. Auxiliary power circuitry malfunction 3. Detection circuit malfunction 	<ol style="list-style-type: none"> 1. Check the input voltage, must >150Vdc 2. Check the auxiliary circuitry inside the inverter 3. Contact customer service for technical support
HW DSP ADC3 (F17)	<ol style="list-style-type: none"> 1. Insufficient input power 2. Auxiliary power circuitry malfunction 3. Detection circuit malfunction 	<ol style="list-style-type: none"> 1. Check the input voltage, must >150Vdc 2. Check the auxiliary circuitry inside the inverter 3. Contact customer service for technical support
HW Red ADC1 (F18)	<ol style="list-style-type: none"> 1. Insufficient input power 2. Auxiliary power circuitry malfunction 3. Detection circuit malfunction 	<ol style="list-style-type: none"> 1. Check the input voltage, must >150Vdc 2. Check the auxiliary circuitry inside the inverter 3. Contact customer service for technical support
HW Red ADC2 (F19)	<ol style="list-style-type: none"> 1. Insufficient input power 2. Auxiliary power circuitry malfunction 3. Detection circuit malfunction 	<ol style="list-style-type: none"> 1. Check the input voltage, must >150Vdc 2. Check the auxiliary circuitry inside the inverter 3. Contact customer service for technical support
HW Eff. (F20)	<ol style="list-style-type: none"> 1. The calibration is incorrect 2. Current feedback circuit is defective 	<ol style="list-style-type: none"> 1. Check the accuracy of current and power 2. Check the current feedback circuit inside the inverter
HW COMM1 (F23)	<ol style="list-style-type: none"> 1. DSP is idling 2. The communication connection is disconnected 3. The communication circuit is malfunction 	<ol style="list-style-type: none"> 1. Contact customer service for technical support 2. Check the connection interface RS-485 3. Check the communication card
HW COMM2 (F22)	<ol style="list-style-type: none"> 1. Red. CPU is idling 2. The internal communication connection is disconnected 	<p>Contact customer service for technical support</p>
Ground Cur. (F24)	<ol style="list-style-type: none"> 1. PV array insulation fault 2. Large PV array capacitance between Plus to Ground or Minus to Ground 3. Either side of boost driver or boost choke malfunction 4. Detection circuit malfunction 	<ol style="list-style-type: none"> 1. Check the insulation of Solar inputs 2. Check the capacitance (+ <-> GND & - <-> GND), must < 2.5uF. Install external transformer if necessary 3. Contact customer service for technical support

Table 6-3C: Fault Codes & Messages

Message	Possible cause	Action
HW Con. Fail (F26)	<ol style="list-style-type: none"> 1. Power line is disconnected inside the inverter 2. Current feedback circuit is defective 	<ol style="list-style-type: none"> 1. Check the power lines inside the inverter 2. Contact customer service for technical support
RCMU Fail (F27)	<ol style="list-style-type: none"> 1. RCMU is disconnected 2. Detection circuit malfunction 	<ol style="list-style-type: none"> 1. Check the RCMU connection inside the inverter 2. Contact customer service for technical support
RLY Short (F28)	<ol style="list-style-type: none"> 1. One or more relays are sticking 2. The driver circuit for the relay malfunction 3. Wrong connection in AC terminal 	<ol style="list-style-type: none"> 1. Check the connection in AC terminal 2. Contact customer service for technical support
RLY Open (F29)	<ol style="list-style-type: none"> 1. One or more relays are abnormal 2. The driver circuit for the relay malfunction 3. The detection accuracy is not correct for Vgrid and Vout 	Contact customer service for technical support
Bus Unbal. (F30)	<ol style="list-style-type: none"> 1. Not totally independent or parallel between inputs 2. PV Array short to Ground 3. Driver for boost is defective or disconnected 4. Detection circuit malfunction 	<ol style="list-style-type: none"> 1. Check the inputs connections 2. Check the PV Array insulation 3. Contact customer service for technical support
HW Bus OVR (F31, F33, F35)	<ol style="list-style-type: none"> 1. Driver for boost is defective 2. Voc of PV array is over 1000Vdc 3. Surge occurs during operation 4. Detection circuit malfunction 	Contact customer service for technical support
AC Cur. High (F36, F37, F38, F39, F40, F41)	<ol style="list-style-type: none"> 1. Surge occurs during operation 2. Driver for inverter stage is defective 3. Switching device is defective 4. Detection circuit malfunction 	Contact customer service for technical support
HW CT A Fail (F42)	<ol style="list-style-type: none"> 1. Test current loop is broken 2. CTP3 is defective 3. Detection circuit malfunction 	Contact customer service for technical support

Table 6-3D: Fault Codes & Messages		
Message	Possible cause	Action
HW CT B Fail (F43)	<ol style="list-style-type: none"> 1. Test current loop is broken 2. CTP4 is defective 3. Detection circuit malfunction 	Contact customer service for technical support
HW CT C Fail (F44)	<ol style="list-style-type: none"> 1. Test current loop is broken 2. CTP5 is defective 3. Detection circuit malfunction 	Contact customer service for technical support
HW AC OCR (F45)	<ol style="list-style-type: none"> 1. Large Grid harmonics 2. Switching device is defective 3. Detection circuit malfunction 	<ol style="list-style-type: none"> 1. Check the utility waveform. Grid connection of inverter needs to be far away from non-linear load if necessary 2. Check all switching devices in inverter stage 3. Contact our customer service for technical support
AFCI Circuit Fail (F58)	<ol style="list-style-type: none"> 1. AFCI is not installed. 2. AFCI self-test is fail. 	<p>Check the AFCI detection circuit board to insure proper connections</p> <p>Contact customer service for technical support</p>
AFCI Fault (F59)	The inverter detects Arcing occurs.	Check PV array cables for replacement
DC Cur. High (F60, F61, F70, F71)	<ol style="list-style-type: none"> 1. Switching device in boost is defective 2. Driver for boost is defective 3. Input current detection circuit malfunction 	<ol style="list-style-type: none"> 1. Check all switching device in boost 2. Check the driver circuit for boost inside the inverter 3. Check input current detection circuit
HW DC RLY (F76)	One or more DC relays are abnormal	Contact customer service for technical support

6.4 Calling for Help

In order for Delta Hotline personnel to efficiently handle your service request, certain information must be made available to the service technician.

Prior to calling the Delta Service Hotline, the information listed below must be assembled:

6.4.1 Service Call Checklist

1. Installation Information
 - a. Location of the install
 - b. How many inverters
 - c. Date of Commissioning (if known)
2. Check the Product Label or use LCD display to view and record:
 - a. Model number
 - b. Serial number
 - c. Production date
3. State of the LCD:
 - a. Is the display active (powered)?
 - b. What is the state of the inverter?
 - c. What is the error message or code?
 - d. Can the Error Log be accessed?
 - i. If, so, please list code number, date and time for any log entry in 24 hr period prior to appearance of error code on LCD screen
4. Status of LED warning lights.
 - a. What LED color(s) are lighted, if any?
 - b. Are the LEDs flashing on and off, or lighted continuously?
5. System configuration:
 - a. What is brand and model of photovoltaic modules?
 - b. What is number of PV modules per string
 - c. Number of strings in each array
 - d. What is maximum array voltage and current values
6. System condition:
 - a. Can the fault or error be reproduced? If so, how?
 - b. Is the fault cyclical in nature? If so, how often?
 - c. Was the fault apparent at the time of installation? If so, has it worsened?
 - d. Describe the atmospheric conditions at the time the fault/error appears or appeared.

Delta Technical Hotline can be reached at **1-877-440-5851** or **1-626-369-8021**.

7 Technical Information

7.1 Technical of M80U series

Table 7-1A: Specifications for M80U

Model	M80U_120	M80U_121	M80U_122
DC Input			
Maximum input voltage	1000V Max.		
Operating voltage range	200 - 1000 V		
Start voltage	> 250 V		
VMPP range for POUT-RATED	600 - 800 V		
Rated voltage	710 V		
Number of MPP trackers	2		
Current limit, IMP-MAX /MPPT	70A/MPPT		
Allowable array ISC-MAX /MPPT	108A/MPPT	160A/MPPT	108A/MPPT
Connection type	16 pr. Fuse holders	2pr. Terminal blocks	18 pr. MC4 connectors
Allowable conductors	#8~#14AWG, Cu only	#1~#3/0 AWG, Cu/Al	#10~#12AWG, Cu only
Surge protection, DC side	SPD Type II 10kA (8 x20us)		
Combiner fuses	32 x 15A	Not Provisioned	36 x 15A
DC disconnect switch	Yes		
String current monitor	Not Provisioned	Not Provisioned	Yes
Rapid Shutdown Transmitter	Not Provisioned	Yes	Not Provisioned
AC Output			
Rated output power	80 kW		
Max. output power	83 kW		
Max. output current	100 A		
Allowable grid configuration	3Ø-4W-Yg or 3Ø-3W		
Rated line voltage	4W: 480/277±10% ; 3W: 480V±10%		
Line frequency range	50/60 Hz		
Power factor	Unity at PRATED; adjustable: [0.8 ind ~0.8 cap]		
Surge protection, AC side	SPD Type II 10kA (8 x20us)		
T.H.D	<3%		
Connection type	AC Switch & Terminal block #1~#2/0		
Night time consumption	< 3W		

Table 7-1B: Specifications for M80U

Model	M80U_120	M80U_121	M80U_122	
Efficiency				
Peak Efficiency	98.8 %			
CEC Efficiency	98.5 %			
Euro Efficiency	98.5 %			
Communications				
Comm port Protocol	RS-485 Delta or Sunspec			
Display	20 x4 line LCD			
Certifications				
Safety	UL1741 SA UL1741, UL1998, UL1699B, CSA C22.2, FCC Pt.15 (Class B), PV Rapid Shutdown System Equipment			
Interconnection	IEEE1547, IEEE 1547.1			
Smart Inverter Functionality				
Smart Inverter Designations	Utility Support Grid Interactive Inverter (UL1741 SA) CEC Approved CA Rule 21 compatible			
Adjustable Controls	V, F Ride-through, PF adjust, Ramp rate control			
Autonomous Functions	Volt/VAR, Volt/Watt, Active power curtailment			
General Data				
Operating T _{AMB} range	-13°~140°F (-25°~60°C)			
Cooling method	Forced air cooling with Smart Fan controls			
Operating elevation	<9800 ft (3000m)			
Environment protection	NEMA 4X			
Noise	69.5 dBA @1m, Amb25°C			
Dimension (W x H x D) (in)	24.2 x 36.3 x 10.8	24.2 x 38.8 x 10.8		
Weight (lb)	W/ Wiring box	182.8	176.2	187.4
	W/O Wiring box	149.9		
	Shipping weight	249.1	246.9	253.5

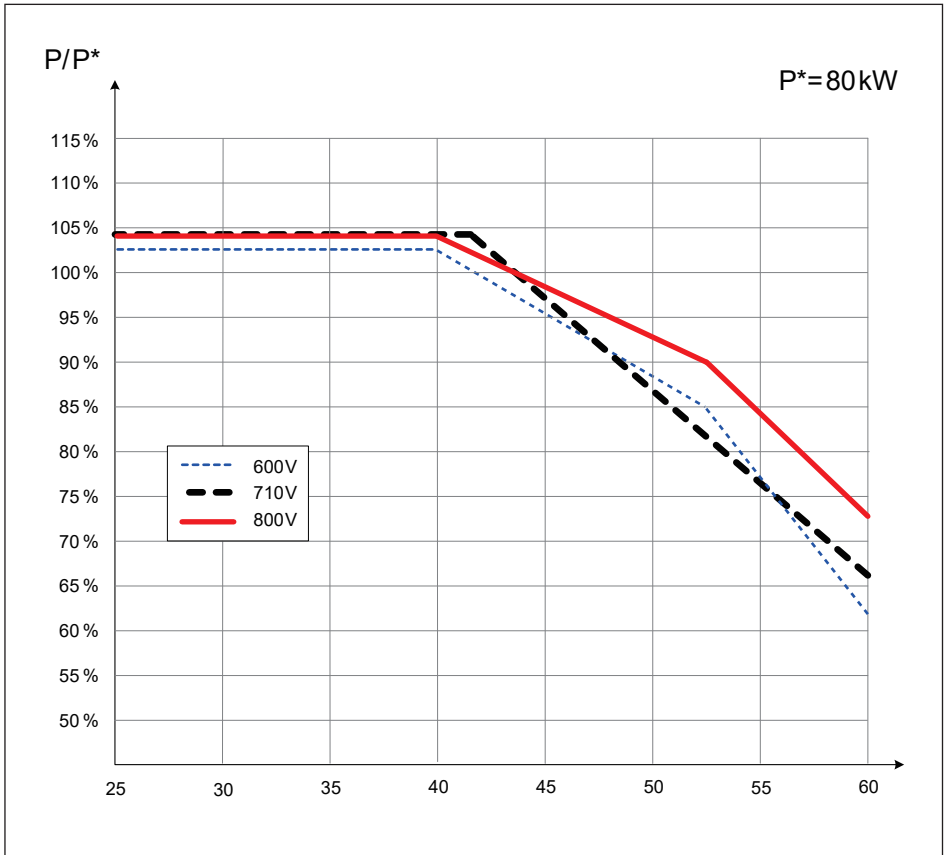

Figure 7-1: Thermal Derating curve of M80U

7.2 Technical of M60U series

Table 7-2A: Specifications for M60U

Model	M60U_120	M60U_121	M60U_122
DC Input			
Maximum input voltage	1000V Max.		
Operating Voltage Range	200 - 1000 V		
Start voltage	> 250 V		
VMPP range for POUT-RATED	520~800V		
Rated voltage	710 V		
Number of MPP trackers	2		
Current limit, IMP-MAX /MPPT	60A/MPPT		
Allowable array ISC-MAX /MPPT	108A/MPPT	160A/MPPT	108A/MPPT
Connection type	16 pr. Fuse holders	2pr. Terminal blocks	18 pr. MC4 connectors
Allowable conductors	#8~#14AWG, Cu only	#1~#3/0 AWG, Cu/Al	#10~#12AWG, Cu only
Surge protection, DC side	SPD Type II 10kA (8 x20us)		
Combiner fuses	32 x 15A	Not Provisioned	36 x 15A
DC disconnect switch	Yes		
String current monitor	Not Provisioned	Not Provisioned	Yes
Rapid Shutdown Transmitter	Not Provisioned	Yes	Not Provisioned
AC Output			
Rated output power	60 kW		
Max. output power	66 kW		
Max. output current	80 A		
Allowable grid configuration	3Ø-4W-Yg or 3Ø-3W		
Rated line voltage	4W: 480/277±10% ; 3W: 480V±10%		
Line frequency range	50/60 Hz		
Power factor	Unity at PRATED; adjustable: [0.8 ind ~ 0.8 cap]		
Surge protection, AC side	SPD Type II 10kA (8 x20us)		
T.H.D	<3%		
Connection type	AC Switch & Terminal block #1~#2/0		
Night time consumption	< 3W		

Table 7-2B: Specifications for M60U				
Model	M60U_120	M60U_121	M60U_122	
Efficiency				
Peak Efficiency	98.8 %			
CEC Efficiency	98.5 %			
Euro Efficiency	98.5 %			
Communications				
Comm port Protocol	RS-485 Delta or Sunspec			
Display	20 x4 line LCD			
Certifications				
Safety	UL1741 SA UL1741, UL1998, UL1699B, CSA C22.2, FCC Pt.15 (Class B), PV Rapid Shutdown System Equipment			
Interconnection	IEEE1547, IEEE 1547.1			
Smart Inverter Functionality				
Smart Inverter Designations	Utility Support Grid Interactive Inverter (UL1741 SA) CA Rule 21 compatible - CEC Approved			
Adjustable Controls	V, F Ride-through, PF adjust, Ramp rate control			
Autonomous Functions	Volt/VAR, Volt/Watt, Active power curtailment			
General Data				
Operating T _{AMB} range	-13°~140°F (-25°~60°C)			
Cooling method	Forced air cooling with Smart Fan controls			
Operating elevation	<9800ft (<3000m)			
Environment protection	NEMA 4X			
Noise	69.5 dBA @1m, Amb25°C			
Dimension (W x H x D) (in)	24.2 x 36.3 x 10.8	24.2 x 38.8 x 10.8		
Weight (lb)	W/ Wiring box	182.8	176.2	187.4
	W/O Wiring box	149.9		
	Shipping weight	249.1	246.9	253.5

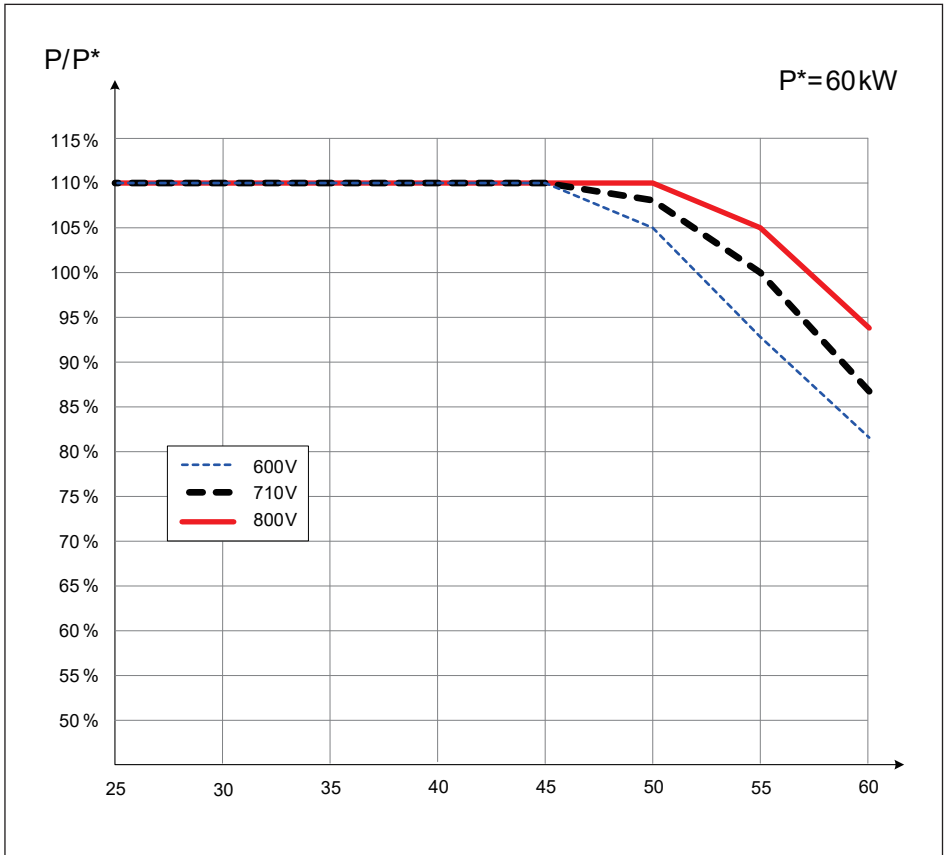

Figure 7-2: Thermal Derating curve of M60U

APPENDIX: Grid Support Utility Interactive Inverters

The inverter has pre-programmed control presets intended for use in specific geographic areas. They include:

- Rule 21 – Preset all required controls to meet the F/VRT specifications that satisfy CA Power Tariff Rule 21
- HECO A – Presets all required controls to meet the for the Hawaiian Islands of O’ahu, Hawai’i Island, and Maui
- HECO B – Presets all required controls to meet the F/VRT specifications for the Hawaiian Islands of Moloka’i and Lana’i

The following sections provide details of the settings and its adjustable range.

Appendix A: CA Rule 21

Appendix A-1: Low and High Voltage Ride-Through Set-points and Timing per Table SA9.1 Default operating parameters that correspond to Rule 21 L/HVRT ^a				
Region	Voltage (% Nominal Voltage)	Ride-Through Until	Operating Mode	Maximum Trip Time (s)
High Voltage 2 (HV2)	$V \geq 120$	Not Applicable	Not Applicable	0.16s
High Voltage 1 (HV1)	$110 < V < 120$	12s	Momentary Cessation	13s
Near Nominal (NN)	$88 \leq V \leq 110$	Indefinite	Continuous Operation	Not Applicable
Low Voltage 1 (LV1)	$70 \leq V < 88$	20s	Mandatory Operation	21s
Low Voltage 2 (LV2)	$50 \leq V < 70$	10s	Mandatory Operation	11s
Low Voltage 3 (LV3)	$V < 50$	1s	Momentary Cessation	1.5s

^a While these operating parameters correspond to the Rule 21 parameters, they may be substituted with operating parameters for other area EPS requirements.
 Note 1: Manufacturer may evaluate product over wider ranges of adjustment than those within the table.
 Note 2: The table voltage could be either at the PCC or equipment terminals.
 Note 3: For LV3 or HV1 the EUT shall cease to energize in not more than 0.16s (and not trip).
 This may differ in other SRD(s).

Appendix A-2: Low and High Frequency Ride-Through Set-points and Timing per Table SA10.1 Default operating parameters that correspond to Rule 21 L/HFRT ^a					
Region	System Frequency Default Settings	Minimum Range of Adjustability (Hz)	Ride-Through Until (s)	Ride-Through Operational Mode	Trip Time (s)
High Frequency 2 (HF2)	$f > 62$	62.0 - 64.0	Not Applicable	Not Applicable	0.16
High Frequency 1 (HF1)	$60.5 < f \leq 62$	60.1 - 62.0	Momentary Cessation	Mandatory Operation	300
Near Nominal (NN)	$58.5 < f \leq 60.5$	Not Applicable	Continuous Operation	Continuous Operation	Not Applicable
Low Frequency 1 (LF1)	$57.0 < f \leq 58.5$	57.0 - 59.9	Mandatory Operation	Mandatory Operation	300
Low Frequency 2 (LF2)	$f \leq 57.0$	53.0 - 57.0	Mandatory Operation	Not Applicable	0.16

^a While these operating parameters correspond to the Rule 21, 2015 parameters, they may be substituted with operating parameters for other area EPS requirements.
 Note 1: Manufacturer may evaluate product over wider ranges of adjustment than those within the table.
 Note 2: Frequency / Watt functionality is an option under the Rule 21, 2015 filing.

Appendix A-3: CA R21 Settings – Normal Ramp Rate (RR) & Soft-Start Ramp Rate (SS)	Alias	M80U	M60U
a) Output Current Rating (A)	Irated	100A	80A
b) Minimum normal ramp-up rate (%Irated /sec)	RRnorm_up_min	1.11%/sec	
c) Maximum normal ramp-up rate (%Irated /sec)	RRnorm_up_max	0.4%/sec	
d) Minimum output current	Ilow	0.1A	
e) Ramp Rate Accuracy MSARR(%Irated /sec)	-	2%	

Appendix A-4: CA R21 Settings – Soft-start ramp rate test	Alias	M80U	M60U
a) Output Current Rating (A)	Irated	100A	80A
b) Minimum soft start ramp-up rate (%Irated /sec)	RRss_min	0.167%/sec	
c) Maximum soft start ramp-up rate (%Irated /sec)	RRss_max	3.33%/sec	
d) Ramp Rate Accuracy MSARR(%Irated /sec)	-	2%	

Appendix A-5: CA R21 Settings – Specified Power Factor	Alias	M80U	M60U
a) Apparent Power Rating (VA)	Srated	83000VA	66000VA
b) Output Power Rating (W)	Prated	83000W	66000W
c) DC Input voltage range with function enabled (V)	Vdc_range	[200V, 1000V]	
d) Nominal AC voltage (V)	Vnom	277V	
e) AC voltage range with function enabled (V)	Vac_range	[249.3V, 304.7V]	
f) AC voltage measurement accuracy (V)	MSAVac	± 2.77V	
g) DC voltage measurement accuracy (V)	MSAVdc	± 10V	
h) Active power range of function, e.g., 20-100% of nameplate	[Plow, Prated]	[16.6kW, 83kW]	[13.2kW, 66kW]
i) Power Factor Accuracy	MSAPF	± 0.01	
j) Power Factor Settling Time	(s)	10s	
k) Minimum Inductive (Underexcited) Power Factor	PFmin,ind	0.8	
l) Minimum Capacitive (Overexcited) Power Factor	PFmin,cap	0.8	
m) PF, the inductive or capacitive signed power factor commanded for test	PFdesird	[0.8cap, 0.8ind]	
n) PFmid,cap = (1 + PFmin,cap)/2, middle of the EUT capacitive range.	PFmid,cap	0.9	
o) PFmid,ind = (1 + PFmin,ind)/2, middle of the EUT inductive range.	PFmid,ind	0.9	
p) POutlimit, the maximum output power either limited by the input supply or by a command to the inverter.	POutlimit	83000W	66000W
q) PFtarget, the target power factor. This will differ from the commanded power factor in 'Active Power Priority' modes for input power greater than PX	PFtarget	[0.8cap, 0.8ind]	

Appendix A-6: CA R21 Settings – Volt/VAr Mode (Q(V))	Alias	M80U	M60U
a) Apparent Power Rating (VA)	Srated	83000VA	66000VA
b) Output Power Rating (W)	Prated	83000W	66000W
c) EUT Input voltage range with function enabled (V)	-	[200V, 1000V]	
d) Nominal AC EPS voltage (V)	Vnom	277V	
e) AC EPS voltage range with function enabled (V)	[Vmin, Vmax]	[249.3V, 304.7V]	
f) Reactive Power Accuracy (% or VAr)	-	± 2.5%	
g) Maximum Ramp Rate (VAr/s)	PRmax	6.1kVAr/sec	4.8kVAr/sec
h) Maximum Rated Reactive Power Production (Capacitive, Overexcited)	Qmax,over cap (VAr)	36500VAr	29000VAr
i) Maximum Rated Reactive Power Absorption (Inductive, Underexcited)	Qmax,under ind (VAr)	36500VAr	29000VAr
j) Maximum Slope (VAr/V)	KVArmax	1.3kVAr/V	1kVAr/V
k) Deadband Range (V)	[Deadbandmin, Deadbandmax]	[0, 28]	
l) Settling Time	(s)	6s	
m) Q1 = the maximum reactive power production setting	% Q1, VArS	36520VAr	29000VAr
n) Q2 = the reactive power setting at the lower voltage deadband limit	% Q2, VArS	0W	
o) Q3 = the reactive power setting at the upper voltage deadband limit	% Q3, VArS	0W	
p) Q4 = the maximum reactive power absorption setting	% Q4, VArS	36520VAr	29000VAr
q) V1 = the voltage at Q1	V1, UV	249.3V	
r) V2 = the voltage at Q2	V2, UV	277V	
s) V3 = the voltage at Q3	V3, OV	277V	
t) V4 = the voltage at Q4	V4, OV	304.7V	

Appendix A-7: CA R21 Settings – Frequency-Watt (FW)	Alias	M80U	M60U
a) Output Power Rating (W)	Prated	83000W	66000W
b) AC frequency range with function enabled (Hz)	[fmin, fmax]	[57Hz, 62Hz]	
c) Manufacturer's stated AC frequency measurement accuracy (Hz or %Hz)	MSAHz	± 0.05Hz	
d) Manufacturer's stated P(f) accuracy (W or %W)	MSAP(f)	± 3%W	
e) Settling Time (s)	ts	10s	
f) Adjustment range of the start of frequency droop (Hz)	[fstart_min, fstart_max]	[60Hz, 65Hz]	
g) Maximum slope of frequency droop (%Prated/Hz)	KPower-Freq_Max	100%	
h) Minimum slope of frequency droop (%Prated/Hz)	KPower-Freq_Min	0%	
i) Slope of the active power response to changes in frequency	KPower_Freq	40%	

Appendix A-8: CA R21 Settings – Volt-Watt (VW)	Alias	M80U	M60U
a) Output Power Rating (W)	Prated	83000W	66000W
b) AC voltage range with function enabled (V)	[Vmin, Vmax]	[249.3V, 304.7V]	
c) Nominal AC voltage (V)	Vnom	277V	
d) AC voltage accuracy (V)	MSAVac	± 2.77V	
e) Output Power accuracy (W)	MSAwatts	± 2.5kW	± 2kW
f) Accuracy of time	MSAt	10ms	
g) Settling Time (s)	ts	10s	
h) Adjustment range of the start of active power reduction (V)	[Vstart_min, Vstart_max]	[277V, 318.5V]	
i) Adjustment range of the stop of the curtailment function (V)	[Vstop_min, Vstop_max]	[249.3V, 277V]	
j) Maximum slope of active power reduction (%Prated/V)	KPower-Volt_Max	N/A	
k) Minimum slope of active power reduction (%Prated/V)	KPower-Volt_Min	N/A	
l) Range of adjustment of a delay before return to normal operation (s)	[treturn_min, treturn_max]	[10s, 900s]	
m) Adjustment range of the rate of return to normal operation (%Prated/Sec)	[KPower_Rate_Min, KPower_Rate_Max]	0.33%/sec	
n) Use of hysteresis in the Volt-Watt function	-	N/A	
o) Slope of the active power response to changes in voltage	KPower_Volt	N/A	
p) Active power rate of return to normal operation	KPower_Rate	0.33%/sec	

Appendix B: HECO

Appendix B-1: Full Frequency Ride-Through Settings for O’ahu, Hawai’i Island, and Maui (HECO A)					
Operating Region	System Frequency Default Settings (Hz)	Minimum Range of Adjustability	Ride-Through Until	Operating Mode	Maximum Trip Time
Over-Frequency 2 (OFR2)	$f > 64.0$	60.1 - 65	No Ride Through	Permissive Operation (Freq-Watt)	0.16 seconds
Over-Frequency 1 (OFR1)	$64.0 \geq f > 63.0$	60.1 - 65	20 seconds	Mandatory Operation (Freq-Watt)	21 seconds
Normal Operation High (NORH)	$63.0 \geq f > 60.0$	Not Applicable	Indefinite	Continuous Operation (Freq-Watt)	Not Applicable
Normal Operation Low (NORL)	$60.0 \geq f \geq 57.0$	Not Applicable	Indefinite	Continuous Operation	Not Applicable
Under-Frequency 1 (UFR1)	$57.0 > f \geq 56.0$	57 - 59.9	20 seconds	Mandatory Operation	21 seconds
Under-Frequency 2 (UFR2)	$56.0 > f$	53 - 57	No Ride Through	Permissive Operation	0.16 seconds

Appendix B-2: Full Frequency Ride-Through Settings for Moloka’i and Lanā’i (HECO B)					
Operating Region	System Frequency Default Settings (Hz)	Minimum Range of Adjustability	Ride-Through Until	Operating Mode	Maximum Trip Time
Over-Frequency 2 (OFR2)	$f > 65.0$	60.1 - 65	No Ride Through	Permissive Operation (Freq-Watt)	0.16 seconds
Over-Frequency 1 (OFR1)	$65.0 \geq f > 63.0$	60.1 - 65	20 seconds	Mandatory Operation (Freq-Watt)	21 seconds
Normal Operation High (NORH)	$63.0 \geq f > 60.0$	Not Applicable	Indefinite	Continuous Operation (Freq-Watt)	Not Applicable
Normal Operation Low (NORL)	$60.0 \geq f \geq 57.0$	Not Applicable	Indefinite	Continuous Operation	Not Applicable
Under-Frequency 1 (UFR1)	$57.0 > f \geq 50.0$	57 - 59.9	20 seconds	Mandatory Operation	21 seconds
Under-Frequency 2 (UFR2)	$50.0 > f$	50 - 57	No Ride Through	Permissive Operation	0.16 seconds

Appendix B-3: Full Voltage Ride-through Settings for O’ahu, Hawai’i Island, Maui, Moloka’i, and Lanā’i						
Operating Region	Voltage at Point of Interconnection (% Nominal Voltage)	Ride-Through Until	Operating Mode	Maximum Trip Time	Return To Service - Trip	
					% Nominal Voltage	Time Delay (s)
Over-Voltage 2 (OVR2)	$V > 120$	No Ride Through	Cease to Energize	0.16** seconds	$110 \geq V \geq 88$	300 - 600*
Over-Voltage 1 (OVR1)	$120 \geq V > 110$	0.92 seconds	Mandatory Operation	1 seconds	$110 \geq V \geq 88$	300 - 600*
Normal Operation High (NORH)	$110 \geq V > 100$	Indefinite	Continuous Operation (Volt-Watt)	Indefinite	Not Applicable	Not Applicable
Normal Operation Low (NORL)	$100 > V \geq 88$	Indefinite	Continuous Operation	Indefinite	Not Applicable	Not Applicable
Under-Voltage 1 (UVR1)	$88 > V \geq 70$	20 seconds	Mandatory Operation	21 seconds	$110 \geq V \geq 88$	300 - 600*
Under-Voltage 2 (UVR2)	$70 > V \geq 50$	10 - 20* seconds	Mandatory Operation	11 - 21* seconds	$110 \geq V \geq 88$	300 - 600*
Under-Voltage 3 (UVR3)	$50 > V$	No Ride Through	Permissive Operation	0.5 seconds	$110 \geq V \geq 88$	300 - 600*

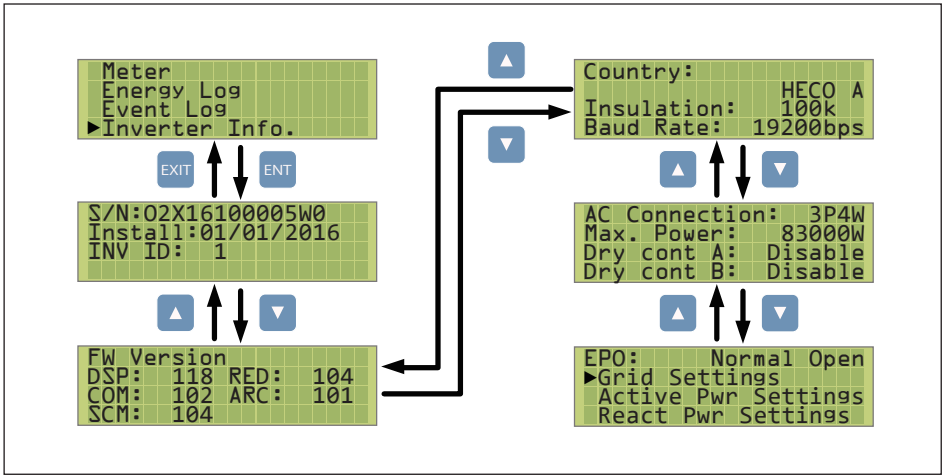

Figure B-1: Procedure to confirm Grid Code via LCD – HECO A shown

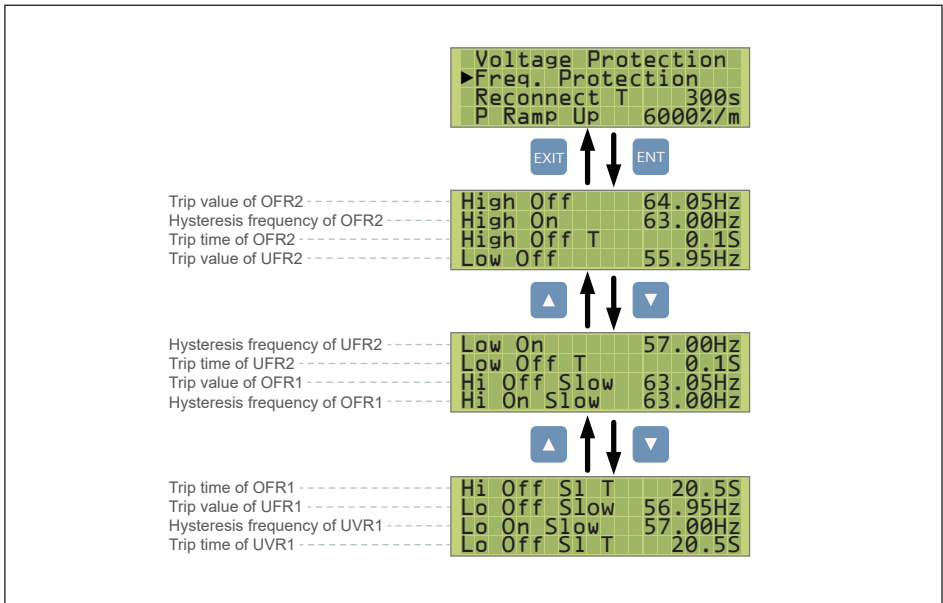

Figure B-2: Details of HECO A: L/H FRT via LCD Settings menu

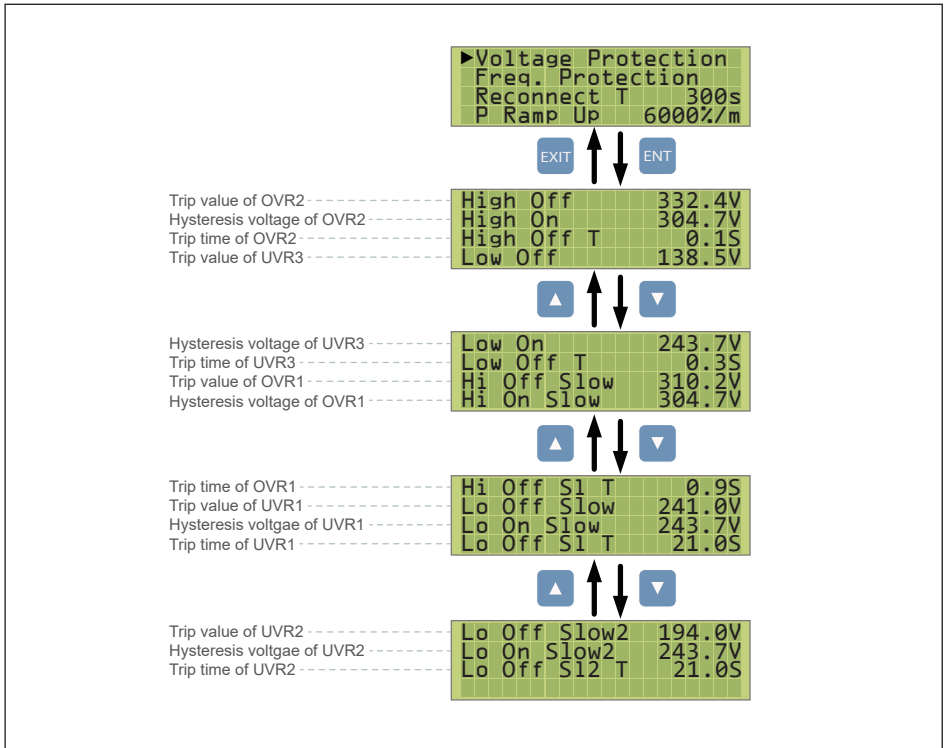
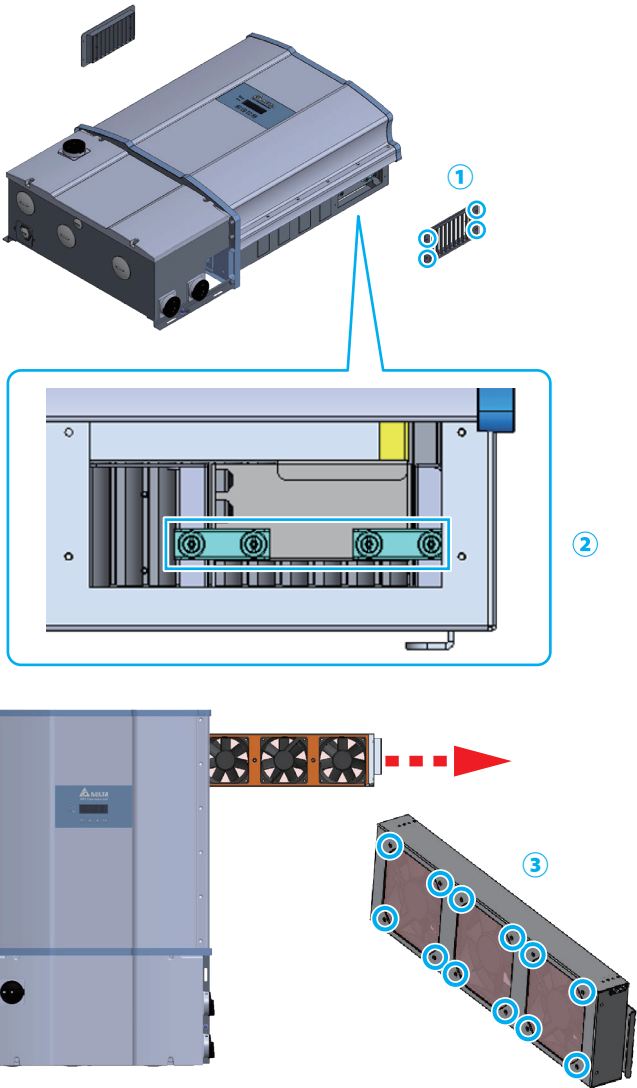

Figure B-3: Details of HECO A & B: L/H VRT via LCD Settings menu

Appendix C: Assembly Note

-All Model



NO	Location	Screw torque
1	Filter	7 lbf-in (0.8N·m)
2	Screw assemblies	7 lbf-in (0.8N·m)
3	Fan	7 lbf-in (0.8N·m)

Appendix C-1: Assembly Note for All model

**120 Model
WB**

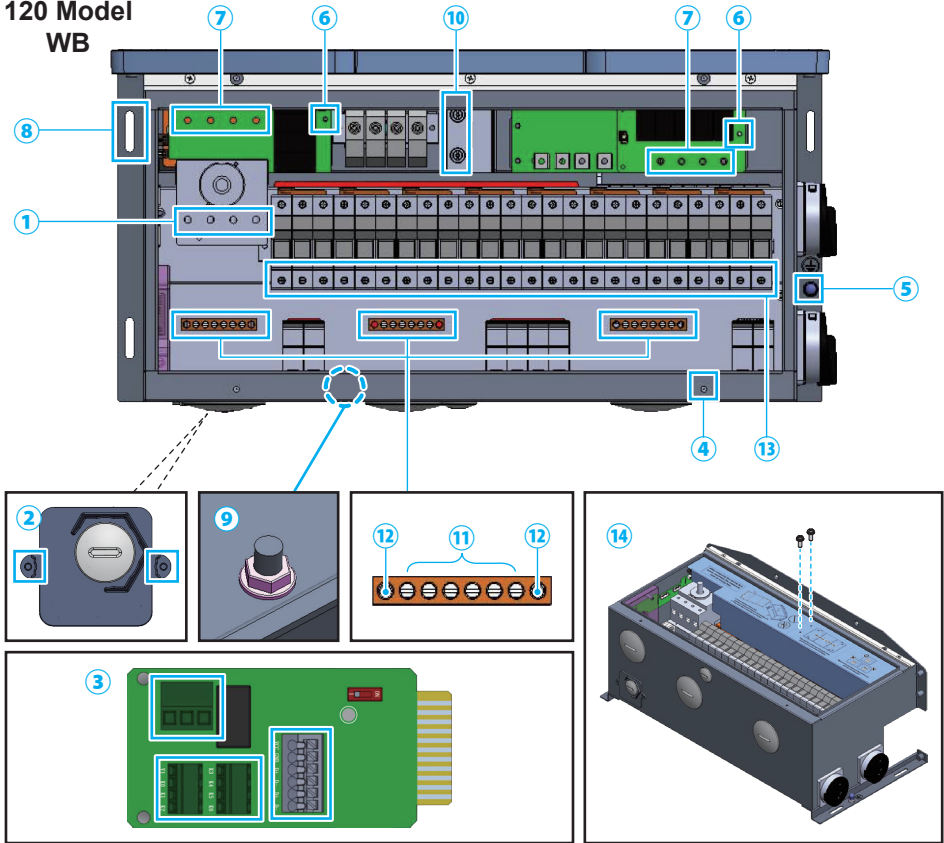

NO	Location	Screw torque	Conductor cross-section
1	AC switch	31.0 lbf-in (3.5N·m)	1~2/0 AWG (35~50mm ²)
2	Communication cover	7.00 lbf-in (0.8N·m)	-
3	Communication port	-	20 AWG (0.5mm ²)
4	Wiring box cover	21.0 lbf-in (2.37N·m)	-
5	Grounding point	69.4 lbf-in (7.8N·m)	-
6	Ground of SPD board	6.90 lbf-in (0.8N·m)	-
7	SPD board	14.6 lbf-in (1.6N·m)	-
8	Mounting bracket	40.0 lbf-in (4.5N·m)	-
9	Grounding screw terminal	80.0 lbf-in (9.0N·m)	1~2/0 AWG (35~50mm ²)
10	Wiring box fan	7.00 lbf-in (0.8N·m)	-
11	Grounding bar	26.0 lbf-in (3.0N·m)	6~4 AWG (14~22mm ²)
12	Mounting screw of grounding bar	22.0 lbf-in (2.5N·m)	-
13	Fuse holder	24.8 lbf-in (2.8N·m)	14~8 AWG (2~8mm ²)
14	Insulator cover	7.00 lbf-in (0.8N·m)	-

Appendix C-2: Assembly Note for 120 model

121 Model WB (With RSD)

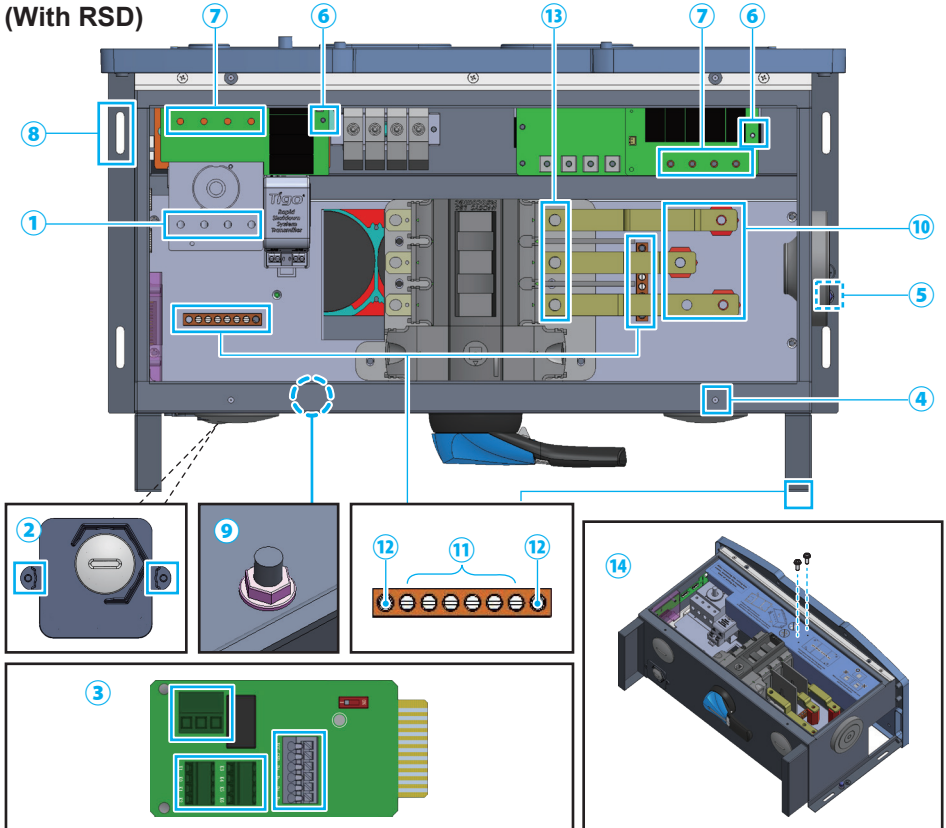

NO	Location	Screw torque	Conductor cross-section
1	AC switch	31.0 lbf-in (3.5N·m)	1~2/0 AWG (35~50mm ²)
2	Communication cover	7.00 lbf-in (0.8N·m)	-
3	Communication port	-	20 AWG (0.5mm ²)
4	Wiring box cover	21.0 lbf-in (2.37N·m)	-
5	Grounding point	69.4 lbf-in (7.8N·m)	-
6	Ground of SPD board	6.90 lbf-in (0.8N·m)	-
7	SPD board	14.6 lbf-in (1.6N·m)	-
8	Mounting bracket	40.0 lbf-in (4.5N·m)	-
9	Grounding screw terminal	80.0 lbf-in (9.0N·m)	1~2/0 AWG (35~50mm ²)
10	DC bus bar	52.0 lbf-in (5.9N·m)	1~3/0 AWG (35~70mm ²)
11	Grounding bar	26.0 lbf-in (3.0N·m)	6~4 AWG (14~22mm ²)
12	Mounting screw of grounding bar	22.0 lbf-in (2.5N·m)	-
13	DC wiring terminal	159.3 lbf-in (18N·m)	1/0~3/0 AWG (50~70mm ²)
14	Insulator cover	7.00 lbf-in (0.8N·m)	-

Appendix C-3: Assembly Note for 121 model (With RSD)

**121 Model WB
(Without RSD)**

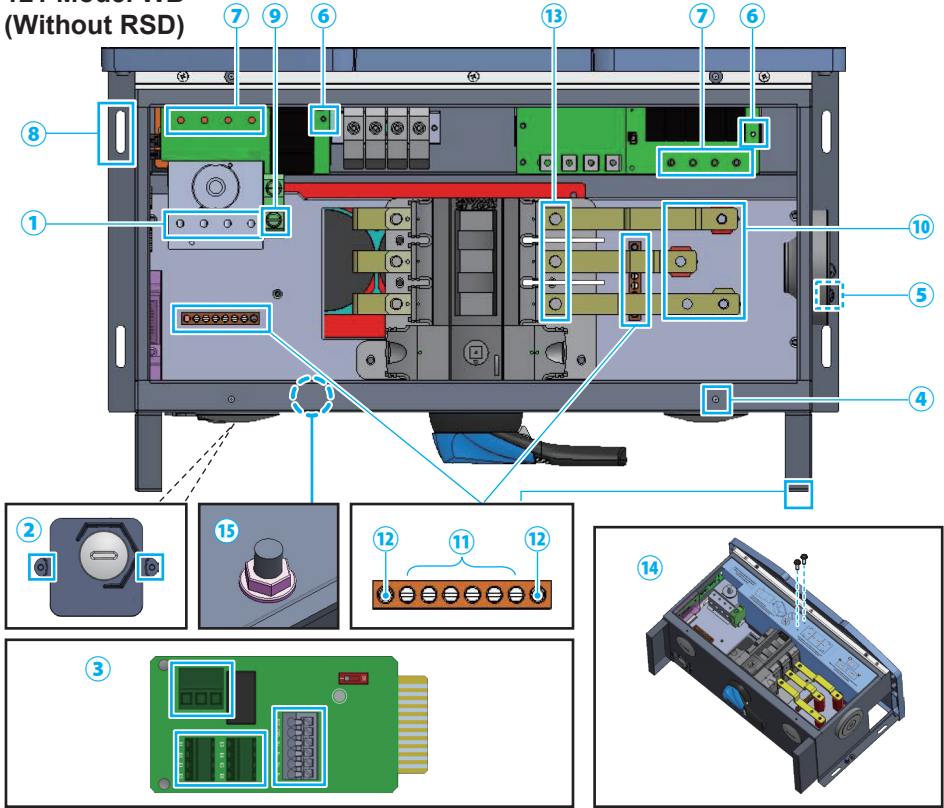

NO	Location	Screw torque	Conductor cross-section
1	AC switch	31.0 lbf-in (3.5N·m)	1~2/0 AWG (35~50mm ²)
2	Communication cover	7.00 lbf-in (0.8N·m)	-
3	Communication port	-	20 AWG (0.5mm ²)
4	Wiring box cover	21.0 lbf-in (2.37N·m)	-
5	Grounding point	69.4 lbf-in (7.8N·m)	-
6	Ground of SPD board	6.90 lbf-in (0.8N·m)	-
7	SPD board	14.6 lbf-in (1.6N·m)	-
8	Mounting bracket	40.0 lbf-in (4.5N·m)	-
9	AC grounding terminal	49.5 lbf-in (5.6N·m)	1~2/0 AWG (35~50mm ²)
10	DC bus bar	52.0 lbf-in (5.9N·m)	1~3/0 AWG (35~70mm ²)
11	Grounding bar	26.0 lbf-in (3.0N·m)	6~4 AWG (14~22mm ²)
12	Mounting screw of grounding bar	22.0 lbf-in (2.5N·m)	-
13	DC wiring terminal	159.3 lbf-in (18N·m)	1/0~3/0 AWG (50~70mm ²)
14	Insulator cover	7.00 lbf-in (0.8N·m)	-
15	Grounding screw terminal	80.0 lbf-in (9.0N·m)	1~2/0 AWG (35~50mm ²)

Appendix C-4: Assembly Note for 121 model (Without RSD)

122 Model WB

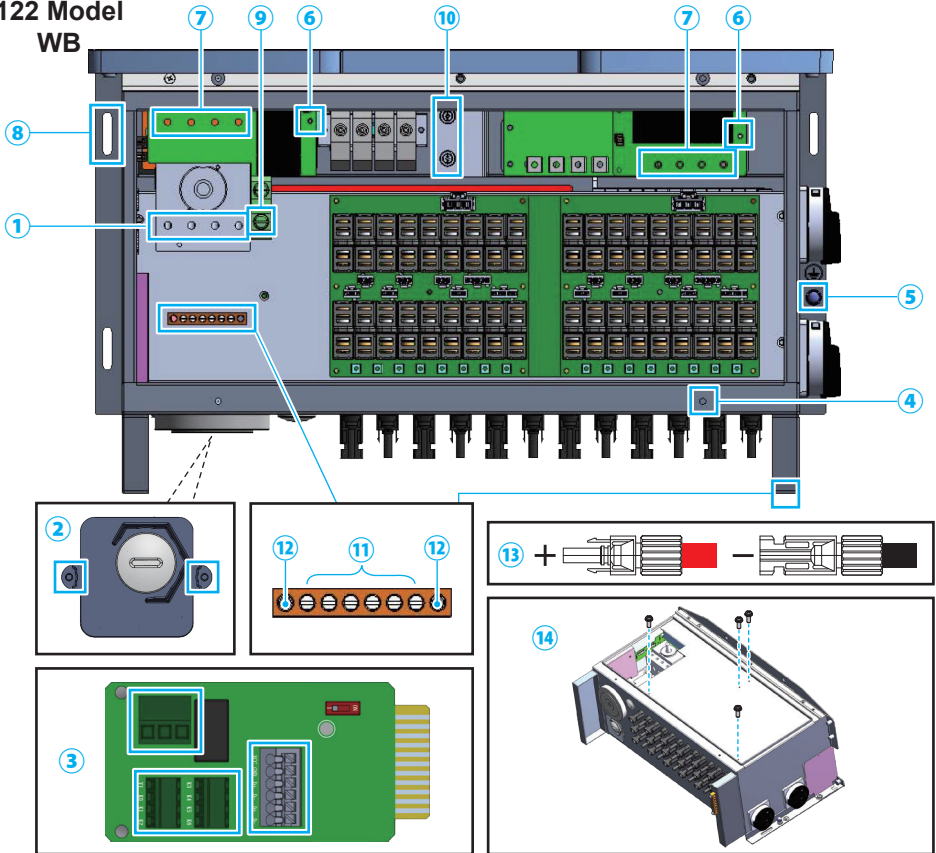

NO	Location	Screw torque	Conductor cross-section
1	AC switch	31.0 lbf-in (3.5N·m)	1~2/0 AWG (35~50mm ²)
2	Communication cover	7.00 lbf-in (0.8N·m)	-
3	Communication port	-	20 AWG (0.5mm ²)
4	Wiring box cover	21.0 lbf-in (2.37N·m)	-
5	Grounding point	69.4 lbf-in (7.8N·m)	-
6	Ground of SPD board	6.90 lbf-in (0.8N·m)	-
7	SPD board	14.6 lbf-in (1.6N·m)	-
8	Mounting bracket	40.0 lbf-in (4.5N·m)	-
9	AC grounding terminal	49.5 lbf-in (5.6N·m)	1~2/0 AWG (35~50mm ²)
10	Wiring box fan	7.00 lbf-in (0.8N·m)	-
11	Grounding bar	26.0 lbf-in (3.0N·m)	6~4 AWG (14~22mm ²)
12	Mounting screw of grounding bar	22.0 lbf-in (2.5N·m)	-
13	MC4 wire	-	12~10AWG (4~6mm ²)
14	Insulator cover	7.00 lbf-in (0.8N·m)	-

Appendix C-5: Assembly Note for 122 model



<http://www.delta-americas.com/solarinverters>

Delta Products Corporation

15700 Don Julian Road

City of Industry, CA 91745

Sales Email: sales.usa@solar-inverter.com

Support Email: support.usa@solar-inverter.com

Sales Hotline: 1-877-440-5851 or 1-626-369-8021

Fax: 1-626-709-5896

Support Hotline: 1-877-442-4832

Support (Intl.) : 1.626.369.8019

Mondays to Fridays from 8:30 am to 5 pm (apart from Holidays)

Version 06211215