



The power behind competitiveness

Delta Data Collector

PPM DC1_100
Installation Manual

Contents

■ Introduction ■

Precautions for Your Safety	03
Essential Points for Safety	05
Precautions for Use	05
1. Preparation before construction	06
1.1.Scope of Delivery	06
1.2.Dimension	07
1.3.Descriptions and Functions of Parts and Components	08
1.4.Reset Method	09
2. Installation	10
2.1.Installation on wall	10
2.2.Installation in box (outdoor)	11
2.3.Setting Connectors and Cables	12
2.4.Connection to the inverter	13
2.5.Download the APP	15
3. Supported inverter models	16
3.1.Normal mode	16
3.2.Retrofit mode	19
3.3. 3rd party monitoring - Modbus tcp/ip	20
3.4. 3rd party monitoring - Modbus RTU (Forward mode)	21
4. Specifications	23
5. When Something Seems Wrong (Troubleshooting)	24
5.1.Error Displays	24
5.2.Troubleshooting	25
Appendix - PPM N1_SB1	26
Appendix - PPM N2_SB1	28
Appendix - PPM N2_WIFI	30
Appendix - PPM P1_120	32
Appendix - PPM P3_120	33



Precautions for Your Safety

■ Notations for safe use of the product and their meanings





This Instruction Manual provides precautions with the following notations and symbols for safe use of the PPM DC1_100. The expression “Product”, “Data Collector” or “DC1” refers to the PPM DC1_100. Precautions described herein contain important aspects of safety.

Please observe and follow these descriptions.

Notations and symbols are described below:

 <b style="font-size: 1.2em;">Warning	<p>Failing to handle the Product properly may result in the described danger leading to slight or intermediate level injuries and in some cases may also result in serious injury or death.</p>
 <b style="font-size: 1.2em;">Caution	<p>Failing to handle the Product properly may result in the described danger leading to slight or intermediate level injuries or property damages in some instances.</p>

■ Explanation of graphic symbols

	<ul style="list-style-type: none"> ● Electric Shock Precaution <p>Notifications pertaining to precautions for potential electric shock, under specific conditions</p>
	<ul style="list-style-type: none"> ● General <p>Unspecified general notifications pertaining to prohibited actions.</p>
	<ul style="list-style-type: none"> ● Disassembly prohibited <p>Notifications pertaining to prohibition of equipment disassembly, when doing so can potentially lead to injuries such as electric shock.</p>
	<ul style="list-style-type: none"> ● General <p>Unspecified general notifications pertaining to instructions for users</p>

Warning

Do not allow any fire producing objects to be near the Product, or apply any spray, including combustible gases, to the Product. The Product may ignite or explode in the unlikely event such an occurrence takes place.



Do not touch the Product with wet hands.
The Product may cause injury due to electric shock or equipment malfunction may occur in the unlikely event such an occurrence takes place.



Do not disassemble or modify the Product.
The Product may cause injury or fire due to electric shock in the unlikely event such an occurrence takes place.



When wiring the power meter, make sure to turn OFF the breakers connected to the power meter. Although small, there is a risk of electric shock.



When installing the DC1, make sure to turn OFF all solar generator breakers and direct current switches for the inverter.
Although small, there is a risk of electric shock.



Caution

Do not install the Product in a place that is subject to significant effects of vibration and impact. There is danger of injury from the Product falling in some rare cases.



Do not use organic solvents (paint thinners, benzene and the like), strong alkaline substances or strong acidic substances to clean the case of the product. There is danger of discoloring the case or the equipment malfunctioning in some rare cases.



When installing the DC1 on a wall made of materials that are not wood, be sure to acquire plastic anchors available on the market to secure the Wall Surface Mounting Plate on the wall surface. There is danger of injury from the Product falling in some rare cases.



Securely tighten the screws using a torque of 0.98 N.m.
Although small, there is a risk of burns due to defective connections.
Do not tighten the wiring using electric tools (drills), whose main purpose is to open holes, such as impact drivers, etc.



Do not install the Product in the following types of locations:
There is danger of burnout in some rare cases.

- Locations that are exposed to rain water, such as outdoors or under eaves and the like.
- Locations that are exposed to steam or where the moisture level is 30 to 85% RH, such as lavatories, changing rooms, work sites, kitchens and the like.



Essential Points for Safety

Items described below must be followed as they are necessary to secure safety.

- Request a specialist to dispose of the product.
- Pull 16-pin terminal and Power supply terminal off when any abnormality is detected like smoke, heat.
- Install the product with the “DELTA” logo facing front when installing the Data Collector on a wall.
- Take care to ensure no water or other liquid gets on the Data Collector.
- The product may malfunction or may be damaged by static electricity. Be sure to remove any static electricity on the body, through such means as touching a metal object nearby, prior to coming into contact with the product.
- Do not connect a telephone line to the LAN terminal on the Data Collector, make sure Ethernet cable is used.
- Store the product in a location with the temperature ranging between -30 and +70°C, with the humidity ranging from 30 to 85% RH.
- Max. 32 inverters can be monitored through RS-485 at one time.
Max. 9 inverters can be monitored through Wi-Fi at one time.

Do not install the product in the following places:

- Do not expose to extreme fluctuation temperature.
- Do not expose to salt air.
- Do not expose to corrosive substances, explosive / flammable GAS, chemicals.
- Do not install in direct sunlight.
- Do not install in a place exceeding the operating temperature range (-25 to +55°C).
- Do not install above 2000m MSL or higher.
- Do not expose to water vapor, oil vapor, smoke, cotton dust, metal powder, sawdust.

※If installed outdoor, please put it in box which is suitable for outdoor use.







Precautions for Use

- The Product may malfunction or may be damaged by static electricity. Be sure to remove any static electricity on the body, through such means as touching a metal object nearby, prior to coming into contact with the Product.
- Store the Product in a location with the temperature ranging between -20 and +55°C, with the humidity ranging from 30 to 85% RH.
- The Product communicates wirelessly.
Install the Product as far away as possible from devices that emit strong radio waves, such as a civil band radio equipment.
- The communication performance varies depending on the peripheral environment. Verify in advance that the Product is communicating normally when installing the Data Collector on a wall.
- Avoid installing the Data Collector near iron plate or steel reinforcements and try to install the Product with as much clear space as possible.

1 .Preparation before construction

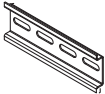
1.1.Scope of Delivery

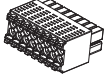
Verify that following items are available for use prior to using this feature.

NO.	Product name	Qty	Remarks	Shape
1	Data Collector	1 unit	Main unit	
2	Wi-Fi Antenna	1 piece	Install antenna to Enhance Wireless Signals.	
3	DIN Rail	1 piece	This is a rail used to install the product on a wall.	
4	DIN Rail Screw (PH2)	3 pieces	These are wood screws for the Wall Surface.	
5	16-pin Connector	1 piece	Connect to the main unit.	
6	DIN Rail Stopper	2 pieces	Stoppers to secure the installation of Data Collector on a DIN Rail.	
7	Quick Installation Guide	1 copy	Installation Guide	

1.2.Dimension

DC1

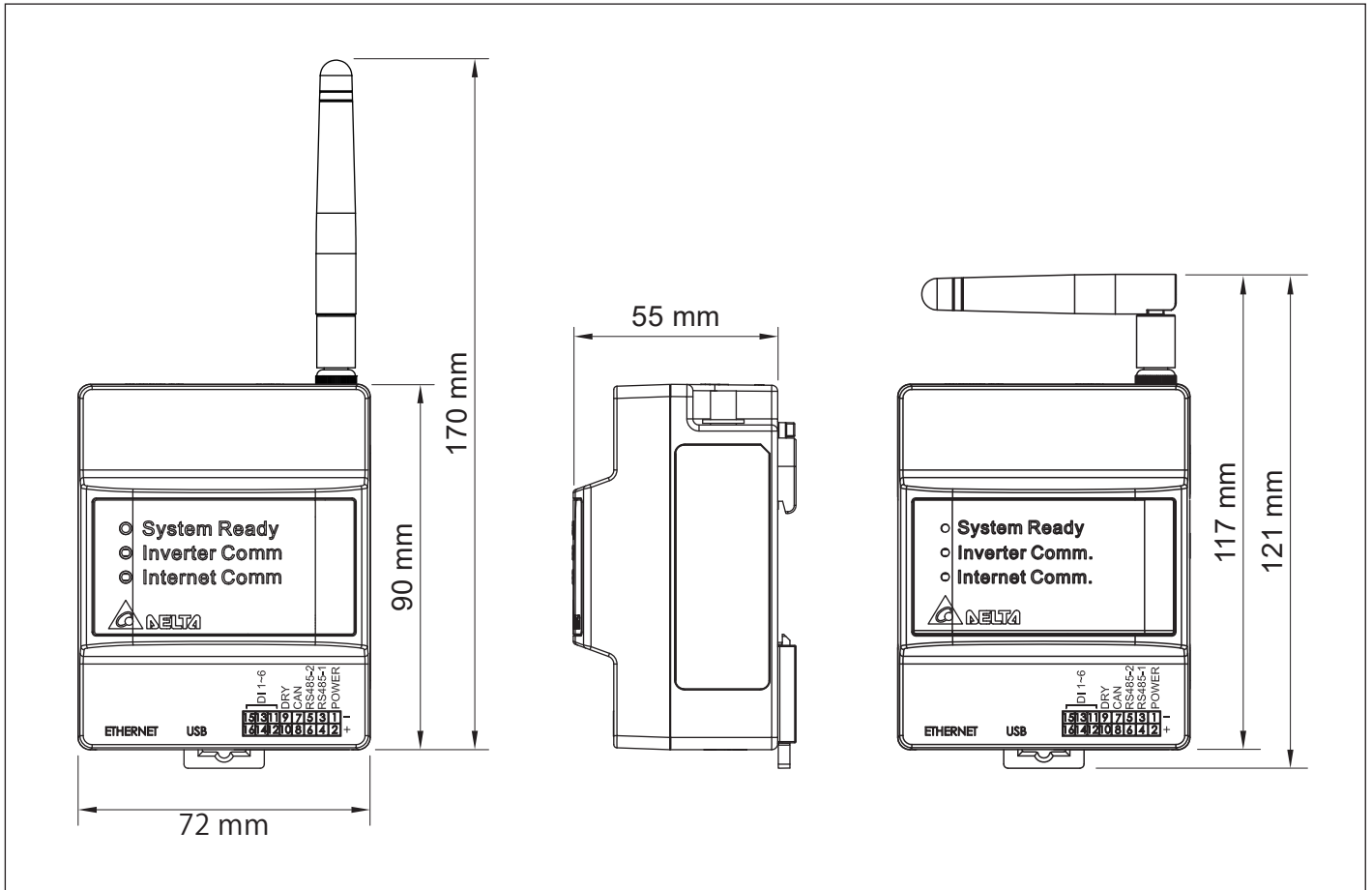

Din Rail

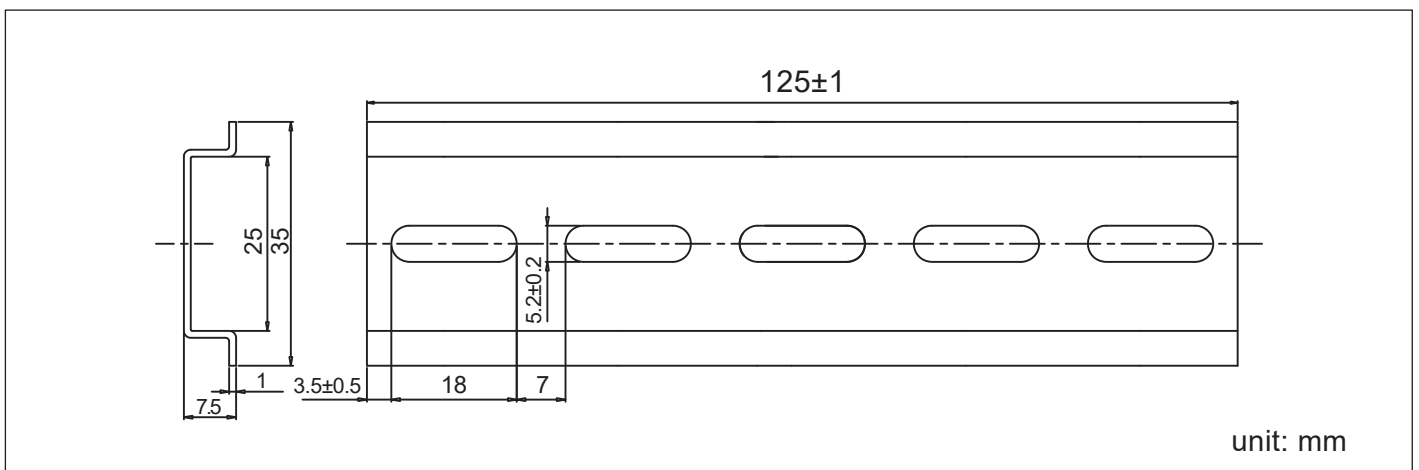

1.3. Descriptions and Functions of Parts and Components

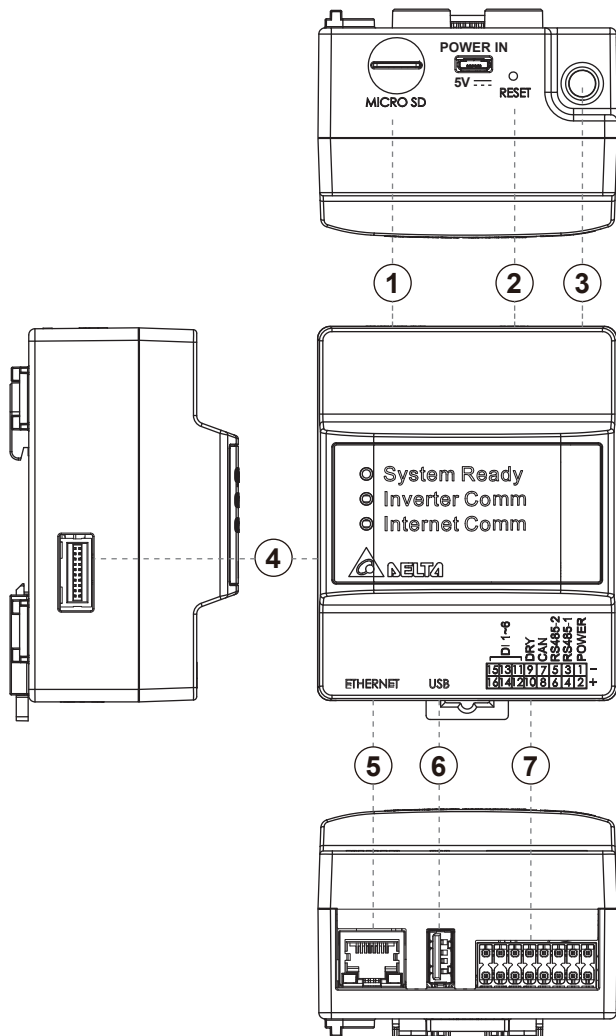

- ① MICRO SD
Use SD card to reset Data Collector to factory default. The settings and records will be deleted.
- ② Reset button
Resetting the Data Collector. Restart the Data Collector. The settings and records will not be deleted.
- ③ Wi-Fi antenna
Install antenna to Enhance Wireless Signals.
- ④ Extend terminal
It is also possible to expand the matching Power Meter for measurement.
- ⑤ LAN terminal (RJ-45 terminal)
This is the terminal that is used to connect the system to an ethernet cable.
- ⑥ USB terminal (for USB)
Reserve of various data and maintenance can be performed.
* Customers are requested to procure their own USB memory.
- ⑦ RS-485 (a 16-pin terminal)
This is the terminal that is used to connect a 16-pin connector provided, to link the supply of power and signals from the Inverter.

Wi-Fi Module

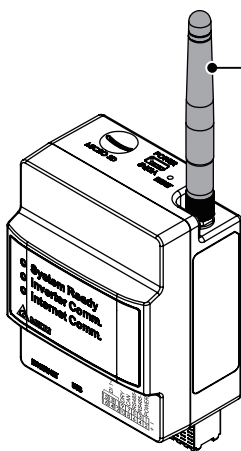

Name	Explanation
Network standard support	IEEE 802.11 b/g/n
Data rates	802.11n 6.5Mbps to 150Mbps (MCS 0-7)
	802.11g 6Mbps to 54Mbps
	802.11b 1Mbps to 11Mbps
Modulation techniques	OFDM with BPSK, QPSK, 16-QAM, 64-QAM
	802.11b with CCK and DSSS
Bandwidth	20MHz/ 40MHz

LED Explanation



Name	LED	Explanation
System Ready	Red	Booting.
	Green	System ready.
Inverter Comm	Green (blinking)	Searching inverters.
	Green	Inverter connected.
Internet Comm	Green	Internet connected.

1.4.Reset Method

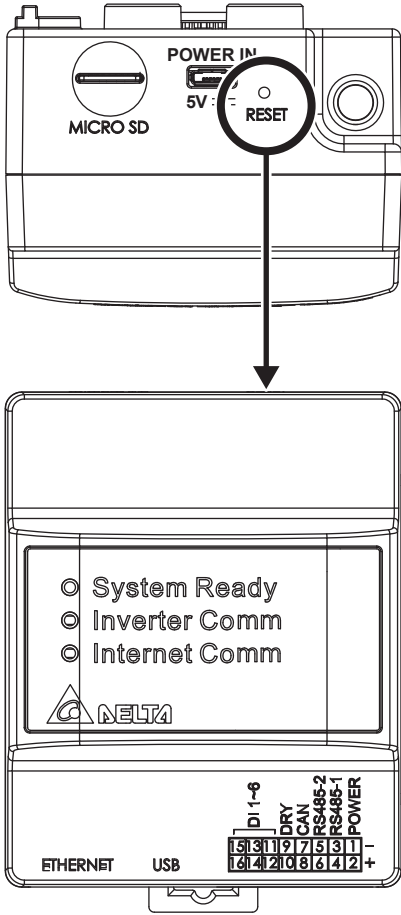

Press reset button	System ready led flashing	Action of DC1
3~5 sec	0.5sec ON, 0.5sec OFF	Rebuild wifi module
6~10 sec	1sec ON, 1sec OFF	Reset wifi password and rebuild wifi module
Over 15sec	2sec ON, 2sec OFF	Reset DC1 setting without SN, then reboot

2. Installation

2.1. Installation on wall

1. DC1

- (1) Use the supplied DIN Rail and mount in distribution cabinet (A).
- (2) Fix the Data Collector on top of the DIN Rail.(B)
- (3) Buckle the Data Collector on the DIN Rail.(C)
- (4) Install two stoppers on the DIN Rail on both side of the Data Collector, then lock in the screws on stoppers to fix these stoppers on the DIN Rail.(D)

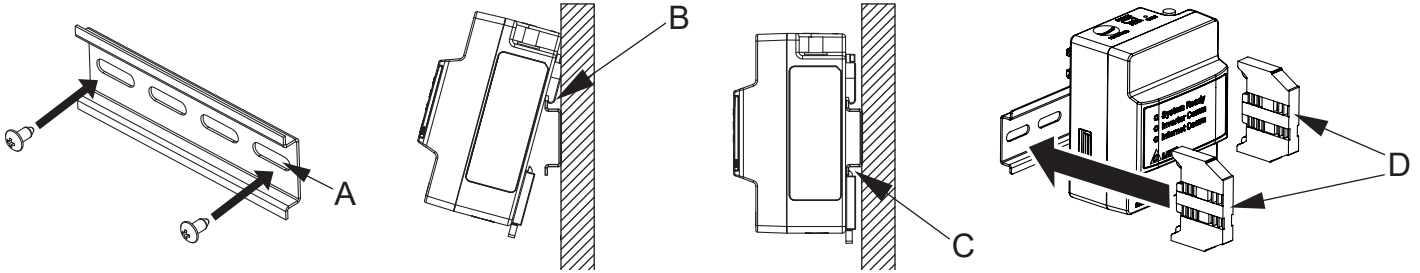

2. DC1 + SUB_1G (N1)

- (1) Use the supplied DIN Rail and mount in distribution cabinet (A).
- (2) Fix the Data Collector on top of the DIN Rail.(B)
- (3) Buckle the Data Collector on the DIN Rail.(C)
- (4) Install two stoppers on the DIN Rail on both side of the Data Collector, then lock in the screws on stoppers to fix these stoppers on the DIN Rail.(D)

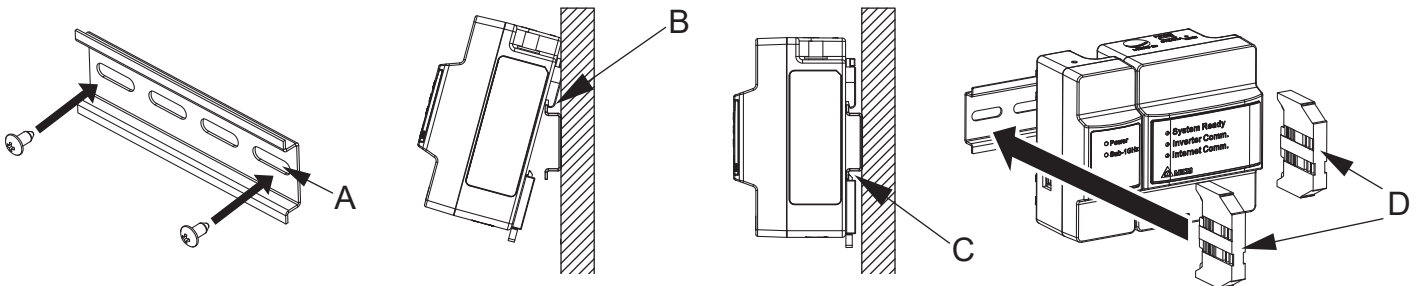

Guidance and Recommendation on the Installation Location of SUB_1G

• Specification of RSSI and SNR

RSSI	> -105 dBm
SNR	> 2 dB

• Solar Panel and Mounting Rack

- Distance of the antenna from solar panel > 10 cm
- Distance of the antenna from mounting rack > 15 cm

• Metal Enclosure

- Distance of the antenna from metal enclosure > 120 cm

• Concrete Block

- Antenna should be placed in front of the concrete block in the transmission path.
- Distance of the antenna from concrete block > 15 cm
- Height difference between antenna and concrete block > 10 cm (antenna placed higher)

• Substation

- Distance of the antenna from the substation > 1.5 m

• High Voltage Transmission Tower

- Distance of the antenna from HV transmission tower > 10 m

2.2. Installation in box (outdoor)

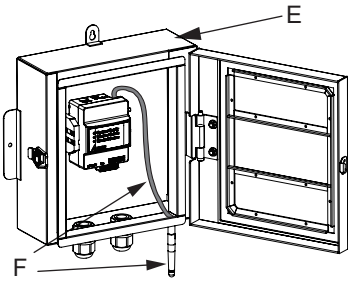

1. DC1

(1) Please prepare a protective case to protect Data Collector (E).

- * If the external box is made of plastic material, Wi-Fi antenna can be installed in the box.
- * If the external box is made of metal, Wi-Fi antenna needs to be installed outside the box (F). User needs to use extension cable to connect the Wi-Fi antenna.

(2) An external box is available for customer from Delta. Contact retailer for more details.

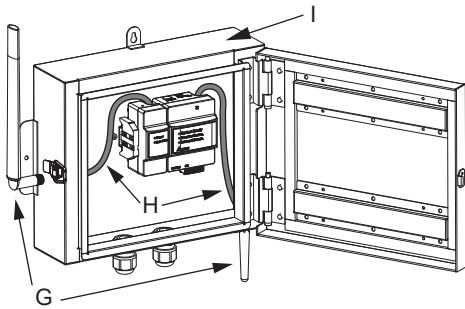
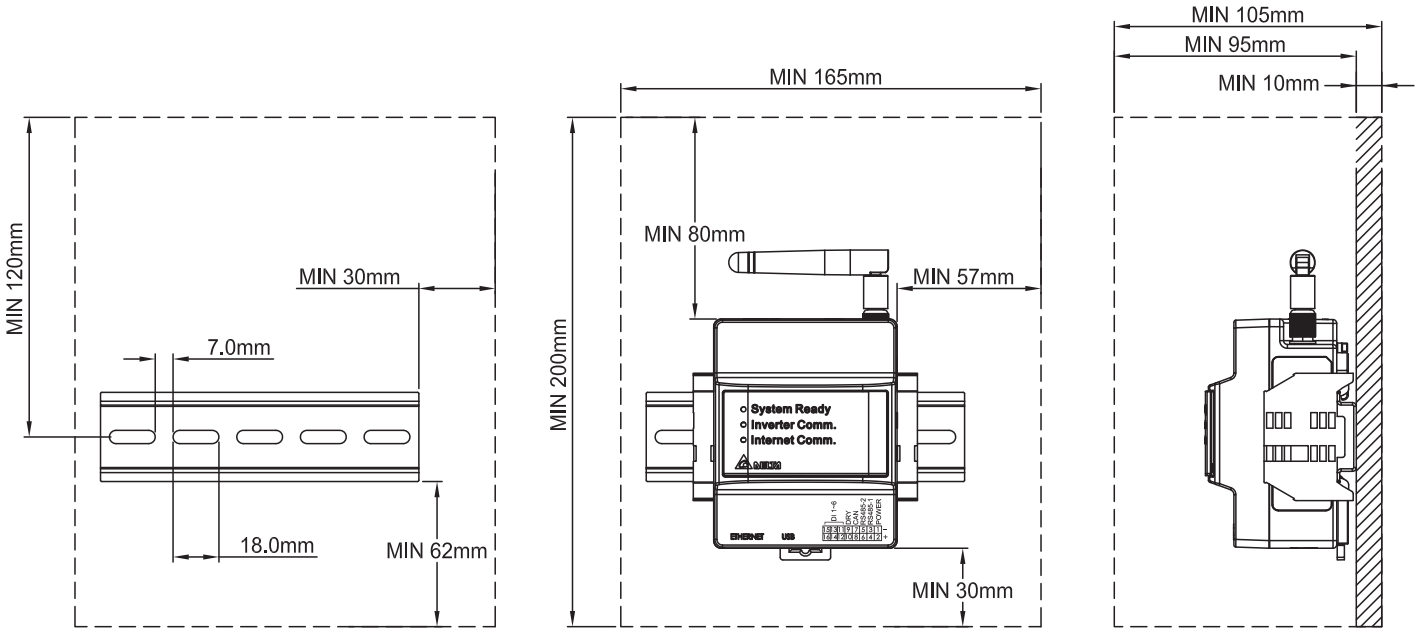

2. DC1 + SUB_1G (N1)

(1) Please prepare a protective case to protect Data Collector and Sub-1GHz module(I)

- * If the external box is made of plastic material, Wi-Fi and Sub-1G antenna can be installed in the box
- * If the external box is made of metal, Wi-Fi and Sub-1G antenna needs to be installed outside the Box (G&H)

(2) An external box is available for customer from Delta. Contact retailer for more details.

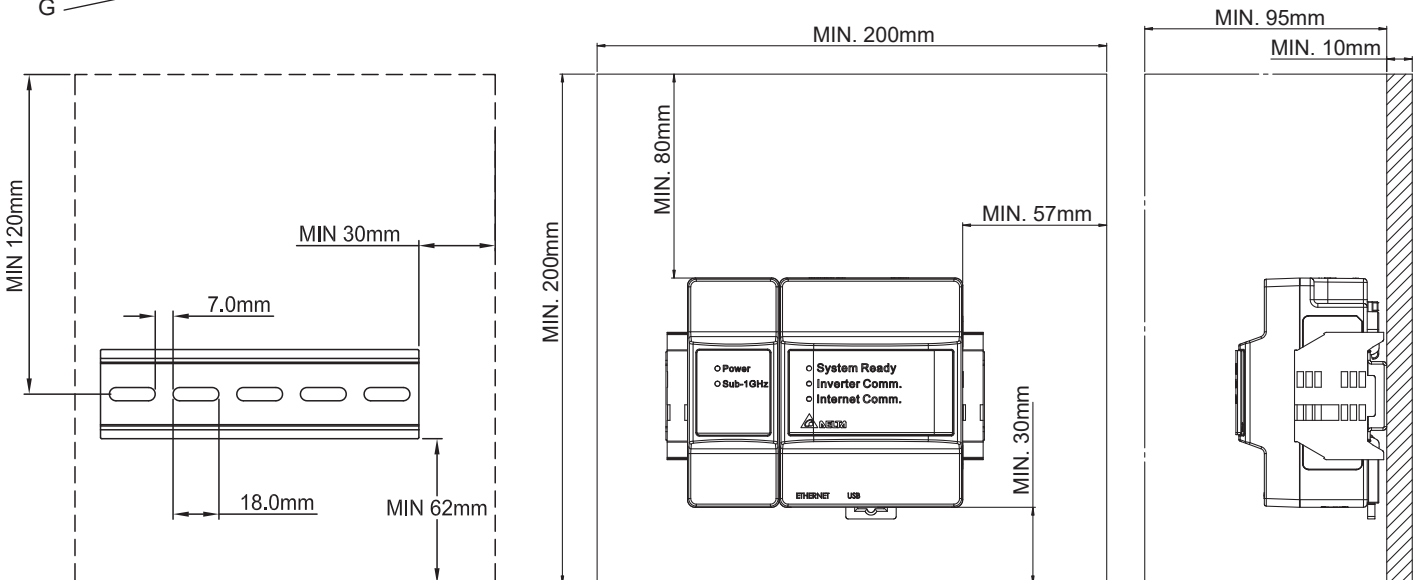

2.3. Setting Connectors and Cables

- Setting cables

Prepare 0.3 to 0.5mm² x single wire, 4 cores (twin wires) shielded cables (rated temperature: 80°C to 85°C).

* Process the cables before use.

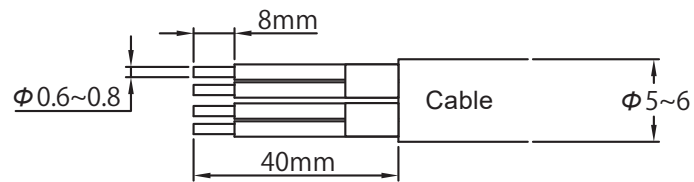

- Assemble 16-pin connector

Hold down the pin ① of 16-pin connector, insert cable and connect connector to Data Collector.

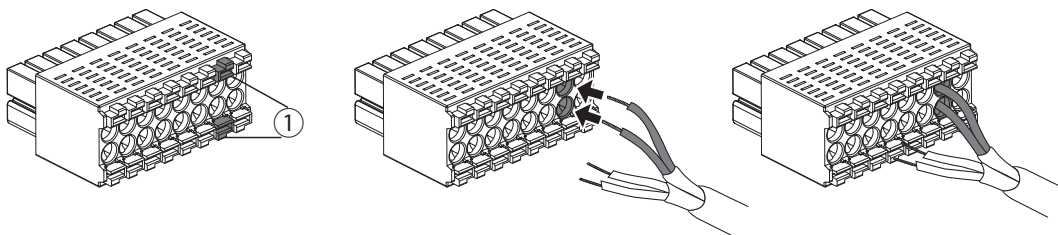

- Assemble communication connector

Hold down pin ① of connector in inverter, insert cable and connect connector to inverter.

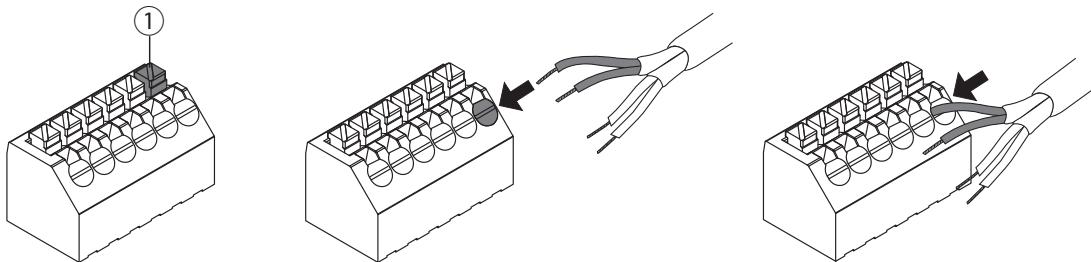

2.4.Connection to the inverter

RS-485

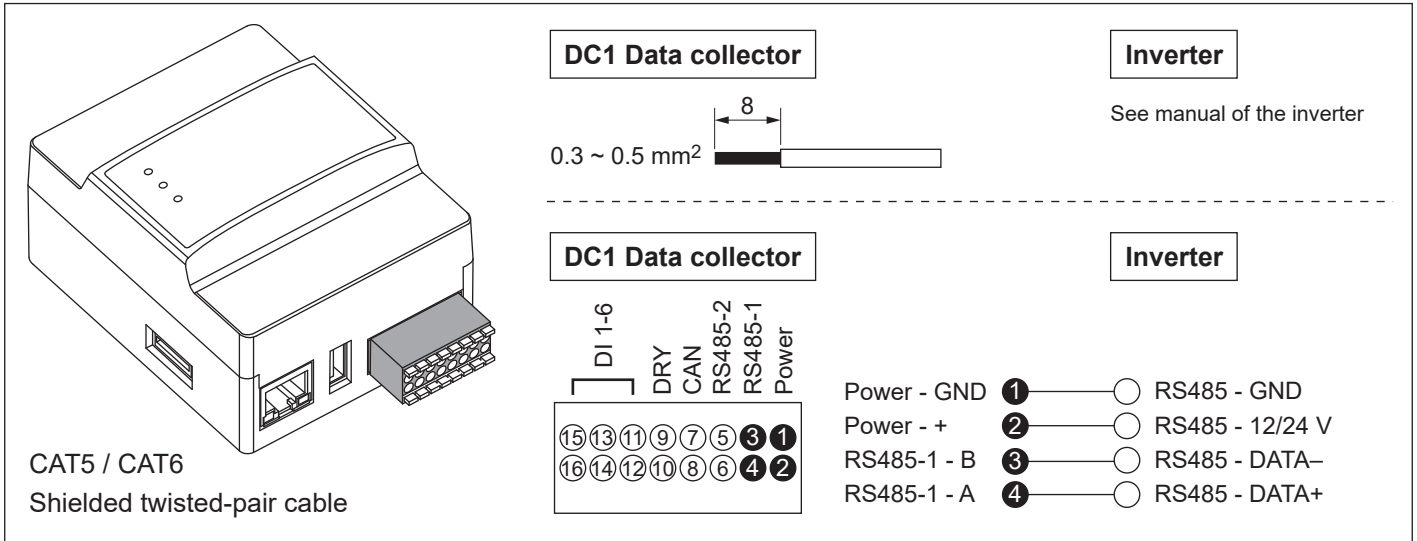

- (1) Remove the communications connectors from the inverter, and thread the cables through the waterproof gasket.
- (2) Hold down the top of the terminal block on the communications connectors, and insert the cables connected to the Data Collector as follows:
1 VCC, 2 GND, 3 DATA+, 4 Data-.
- (3) Next, insert the cables into the adjacent inverter as follows: 5 Data+, 6 Data-. Check that the cables have been inserted securely.
- (4) Next, insert the aforementioned cables into the adjacent inverter as follows: 3 Data+, 4 Data-.
- (5) After completing the connection, turn ON the terminal switch for only the inverter that is farthest from the Data Collector, and set all the other inverter to 1 (OFF).

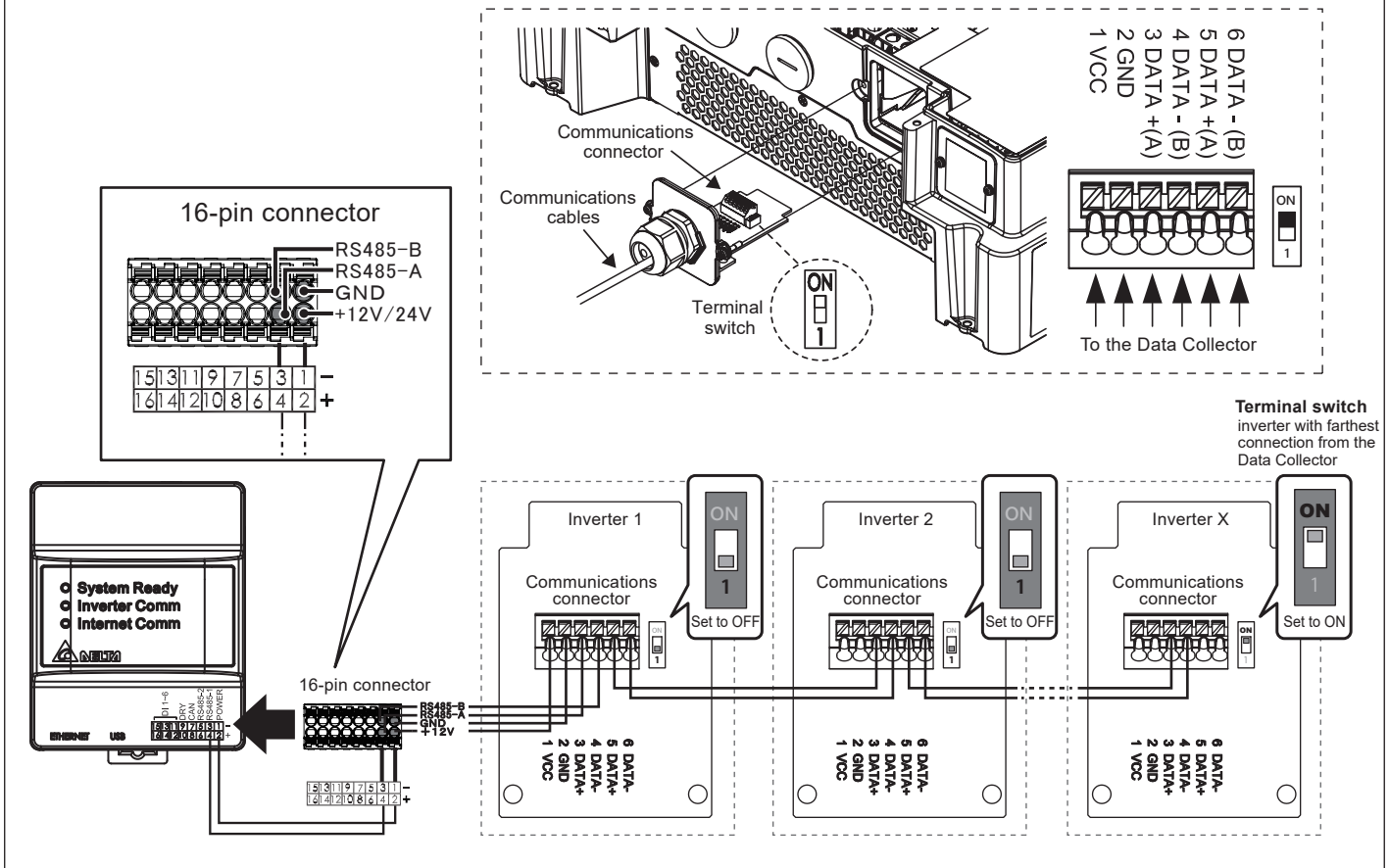

SUB_1G (PPM N2_SB1)

- Install SUB_1G to inverter.
- Refer the figure and connect each wire to the communication card of inverter.

* Screw torque required for assembling: 1.6 N·m

Inverter comm. module

Red VCC
Black GND
White D+
Green D-

SUB_1G

6 DATA-
5 DATA+
4 DATA-
3 DATA+
2 GND
1 VCC

SUB_1G (PPM N3U_SB1)

- Install SUB_1G to inverter.

Remove the nut.

Save the nut after antenna installed.

Use the wrench to lock antenna with 1.2 N·m torque.

13mm Open end wrench

Wi-Fi (PPM N2_WIFI)

- Install Wi-Fi Module to inverter. (Take M70A for example.)
- Refer the figure and connect each wire to the communication card of inverter.

* Screw torque: 1.6 N·m

1.7 m

Inverter comm. module

Red VCC
Black GND
Yellow D+
Blue D-

Wi-Fi Module

6 DATA-
5 DATA+
4 DATA-
3 DATA+
2 GND
1 VCC

Installation for other models

* When using N2_WiFi for inverter, the RS485 of inverter will not available to use.

ATTENTION



To establish a successful communication between Inverter Wi-Fi to MyDeltaSolar Cloud, in the Wi-Fi connection setup page, the signal strength must be above **-70dBm** between each Wi-Fi device (Wi-Fi router, inverter, DC1...etc.). In case the signal strength is below -70dbm, it may cause certain communication errors which may prevent a successful Wi-Fi communication. To avoid such issues, Please adjust the Wi-Fi device position to improve the signal strength/quality.

2.5.Download the APP



MyDeltaSolar

1. This APP should collocate with Delta Inverter.
2. If inverter is not connected to cloud, you still can monitor inverter operation by APP.
3. Scan QR code for APP operation manual.



QR Code



iOS



Google Play and the Google Play logo are trademarks of Google LLC.

Android

Where can search for MyDeltaSolar APP?

- QR Code: Please scan the QR code to MyDeltaSolar cloud.
- IOS system: Please search "MyDeltaSolar" in App store.
- Android system: Please search "MyDeltaSolar" in Google Play.



About OS version

iOS: 8.0 and above
Android OS: Android 5.0 and above

ATTENTION



- Please check the smart phone is connected to the Internet and the communication is good.
- Before going to the site, please registered an account and sign once in an internet-connected environment.

3.DC1 system application



When 3rd party monitoring and delta cloud monitoring are using at same time, suggest to add below IP into network white list to make sure remote function and cloud monitoring work normal.
 Back end remote function IP : 52.187.179.41
 Cloud monitoring IP : 52.237.74.126
 Suggest 3rd party monitoring system can enable VPN or Port forwarding function of the local router, so Delta service will able to remote debug when needed.

3.1.Normal mode

Inverter connect with DC1 via Wired (RS-485) or Wi-Fi, DC1 transfer inverter data to Delta Cloud.

RS-485

The RS-485 Inverter is set by operating the DC1 through the APP. Upload power generation data to Cloud Server for monitoring.

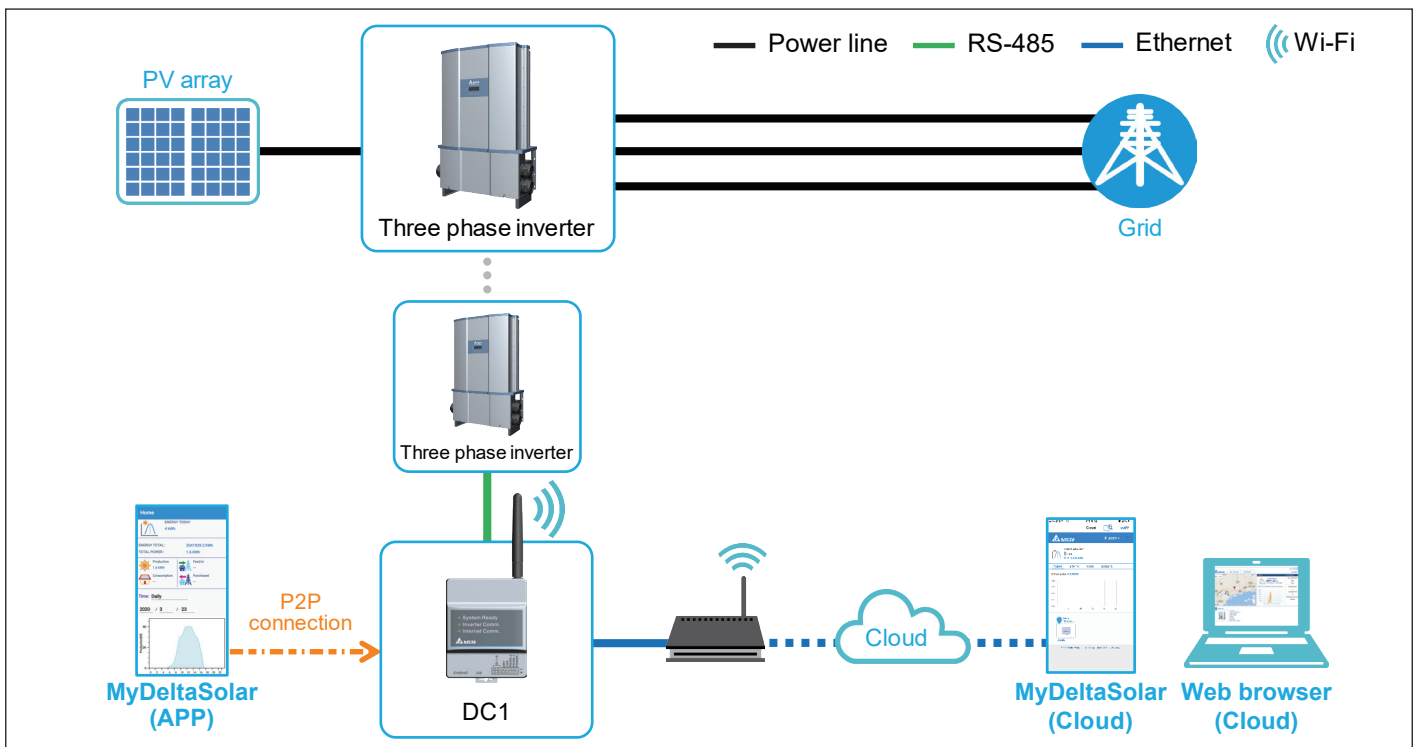

Wi-Fi

The WI-FI Inverter is set by operating the DC1 through the APP. Upload power generation data to Cloud Server for monitoring.

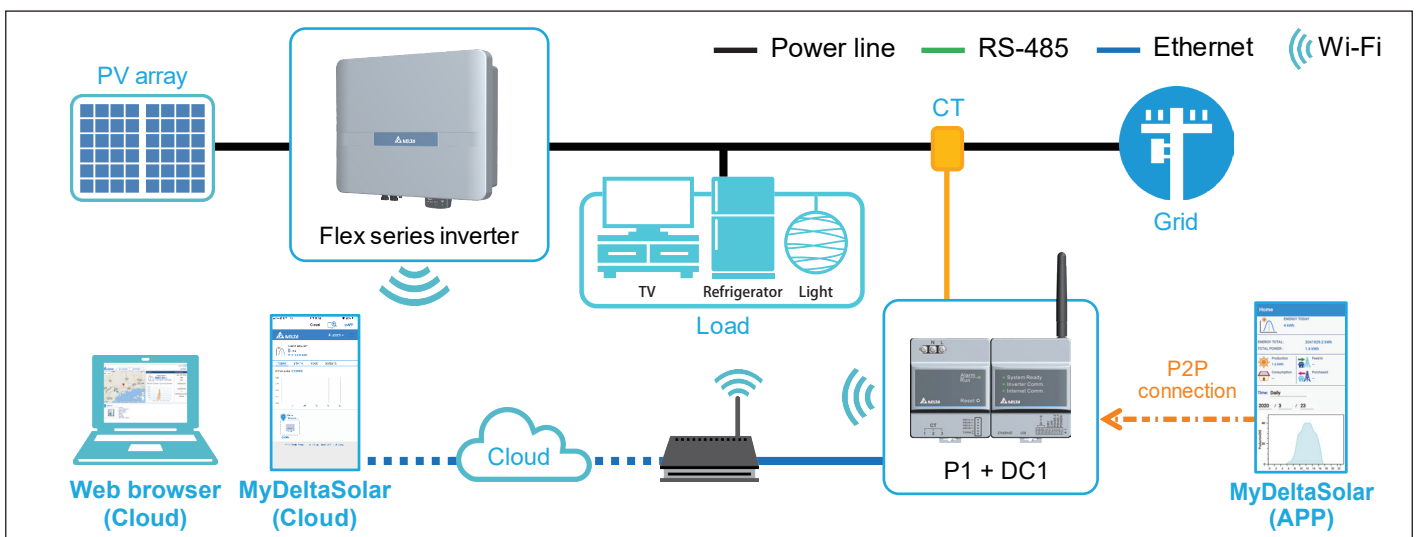

SUB_1G

• **What is SUB_1G?**

SUB_1G is a wireless communication with a frequency lower than 1GHz. Compared with 2.4GHz Wi-Fi, SUB_1G has a longer transmission distance, stronger penetrate and can cover a larger range, so it is suitable for a wide range field. Compared to the traditional RS485, SUB_1G do not have to do RS485 wiring work and can save the cost.

• **How to set up SUB_1G efficiently?**

To make the Data Collector and Inverters communicate better with largest coverage, please install the Data Collector in the middle of the block.

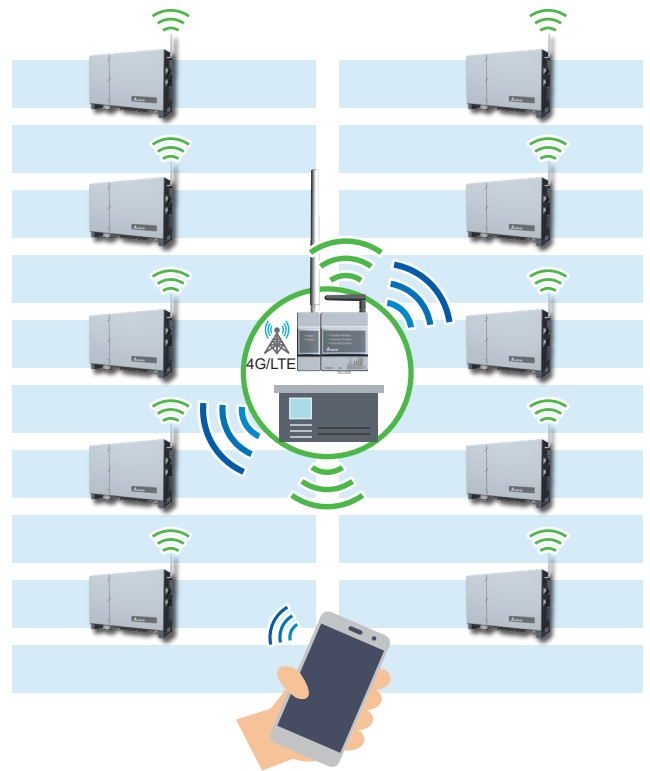

To monitor the field, each block will have one Data Collector (DC1) to transmit wireless signal through Sub-1G device (N1) and Inverter (N2 or N3). With the app, users can connect Inverter and Data Collector, and then upload the collected data to the Delta Cloud by Ethernet or Wi-Fi, or upload to the 3rd party monitoring by LAN for management.

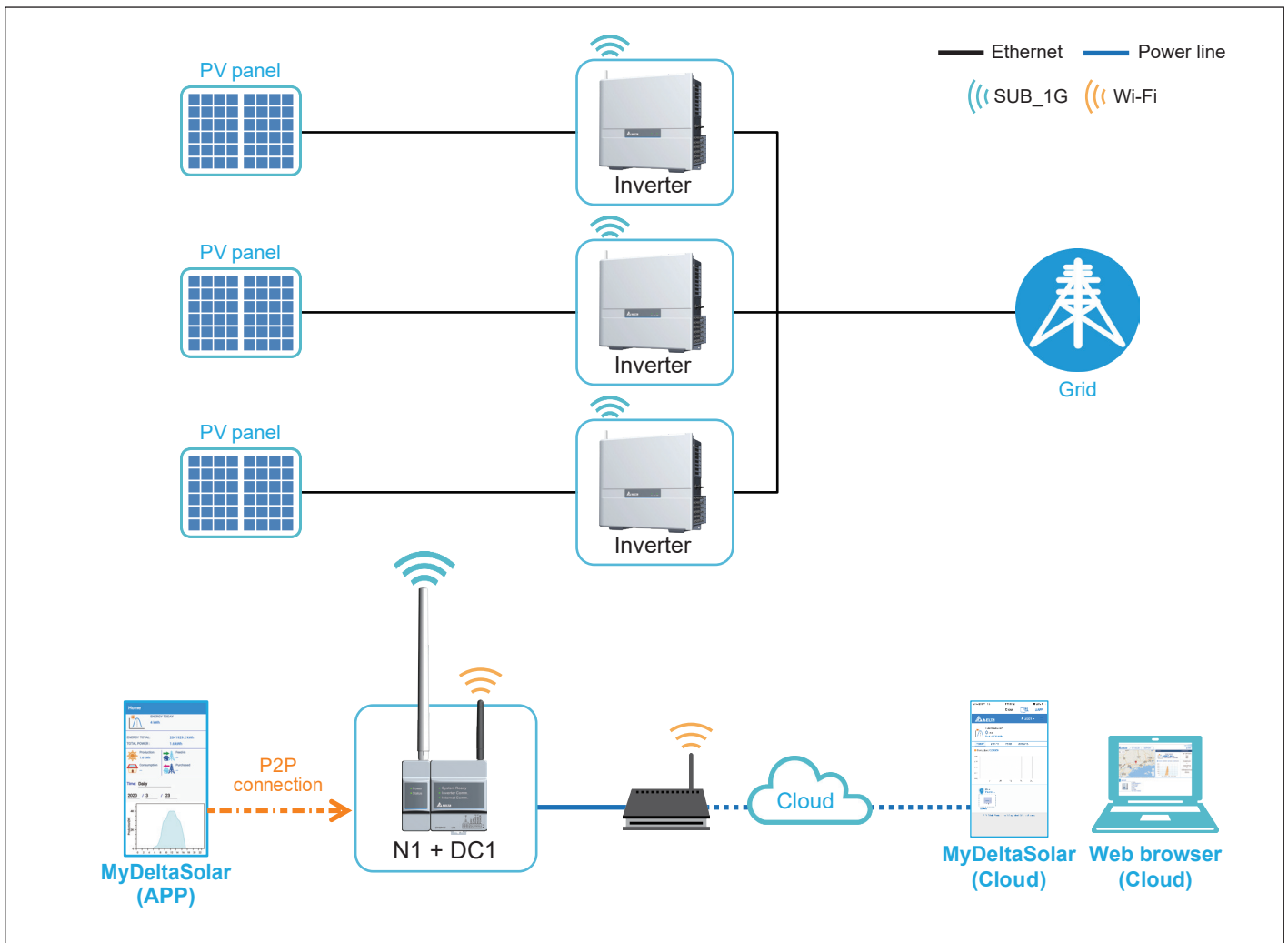

Connection type	Wired (RS-485)	Wi-Fi	SUB_1G	Mixed
Solivia G3	○	—	—	○
Solivia G4	○	—	—	○
RPI HxA	○	—	—	○
HXA_2xx	—	○	—	○
M6/8/10A	○	○	—	○
M15/20A	○	○ (N2_WIFI)	—	○
M30A	○	○ (N2_WIFI)	—	○
M50A_12s	○	○ (N2_WIFI)	○ (N2_SB1)	○
M88H	○	○ (N2_WIFI)	○ (N2_SB1)	○
M15/20/30A_2xx	○	○	○ (N2_SB1)	○
M50/70A_2xx	○	○ (N2_WIFI)	○	○
M100_210	○	○ (N2_WIFI)	○	○
M100A_280	○	○ (N2_WIFI)	○	○
M125HV	○	○ (N2_WIFI)	○	○
M250HV	○	○ (N2_WIFI)	○	○

Wired: max 32 inverters

Wi-Fi: max 9 inverters

Mixed: max 32 inverters

SUB_1G: max 25 inverters

● **Connection type DC1 - Router**

Ethernet or Wi-Fi

● **Connection type DC1 - Smartphone**

Wi-Fi

3.2.Retrofit mode

Converts data into SOLIVIA protocol.

Connection type	Wired (RS-485)	Wi-Fi	Mixed
Solivia G3	not available	—	not available
Solivia G4		—	
RPI HxA		—	
HXA_2xx		○	

Note

One of the connected inverters must have RS485 ID (Inverter ID) = 1

3.2.Retrofit mode

This function is only for Solivia Gateway, the Wi-Fi inverter is set by DC1 through the APP.
Start Solivia Gateway to monitor on Solivia Cloud.

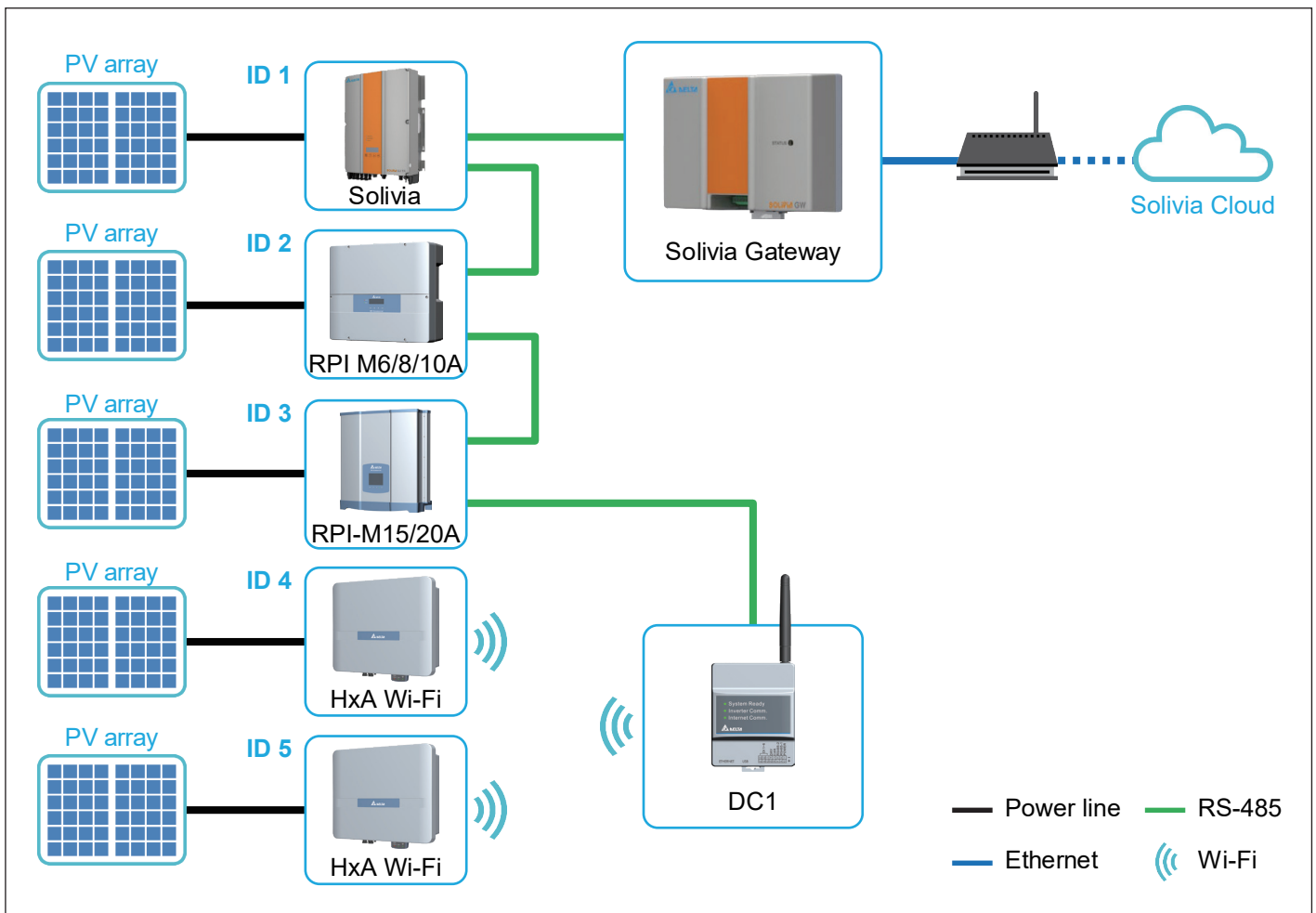

Connection type	Wired (RS-485)	Wi-Fi	Mixed
Solivia G3	not available	—	not available
Solivia G4		—	
RPI HxA		—	
HXA_2xx		○	

Note

One of the connected inverters must have RS485 ID (Inverter ID) = 1

3.3. 3rd party monitoring - Modbus tcp/ip

RS-485 or Wi-Fi inverter is set by DC1 through the APP.

After the setting is completed, the third-party monitoring reads the communication address of DC1 through Modbus to get the power generation data.

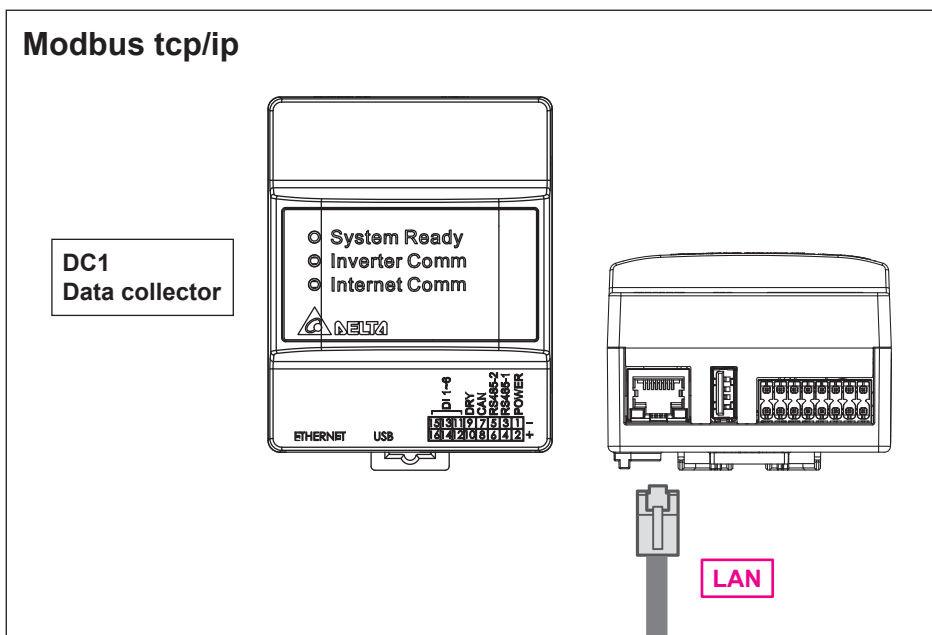
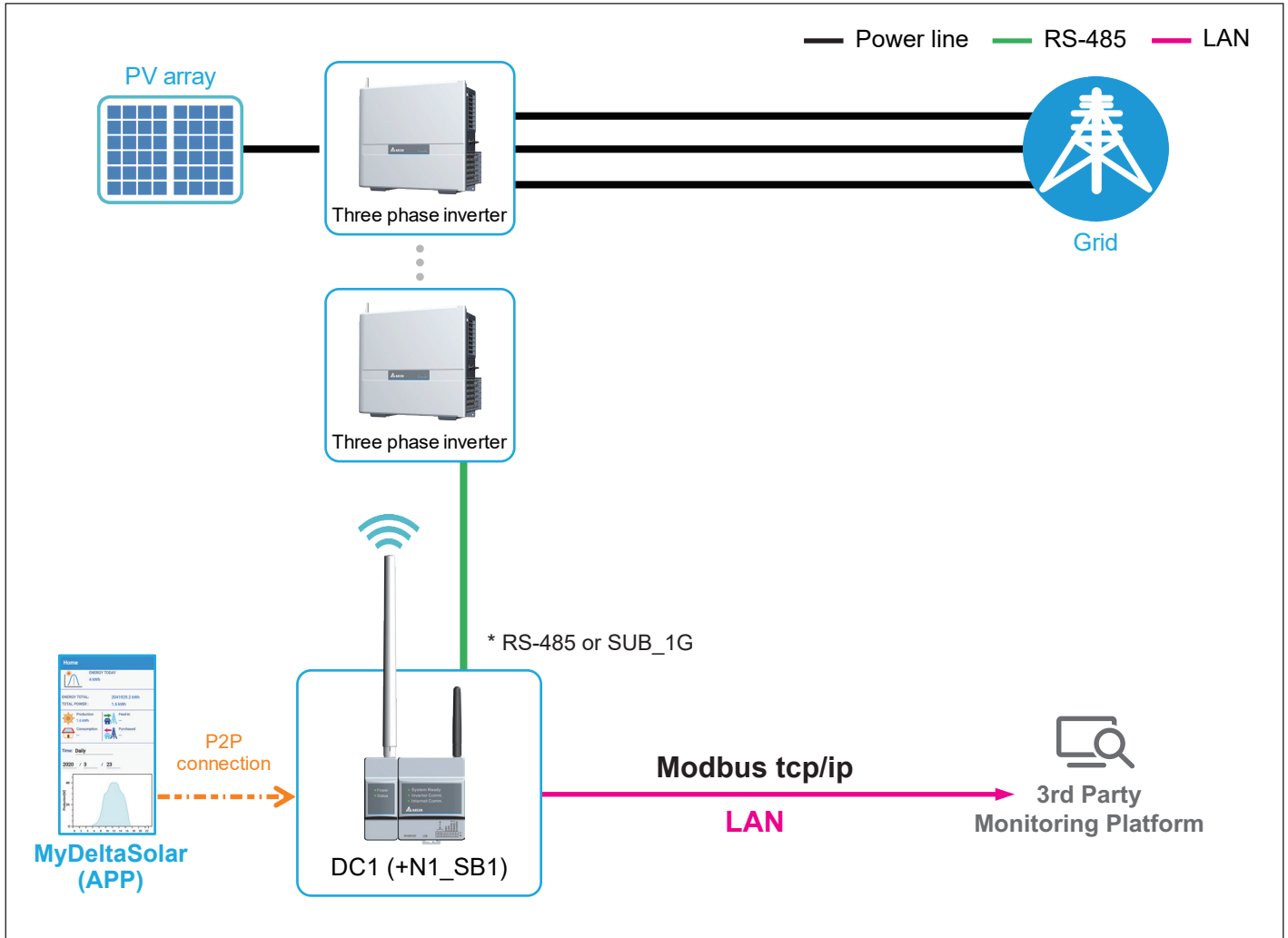

3.4 3rd party monitoring - Modbus RTU (Forward mode)

3rd party monitoring device with Delta Modbus RTU protocol address built in can be used.
 DC1 is master of inverters, also the slave of 3rd party monitoring device.

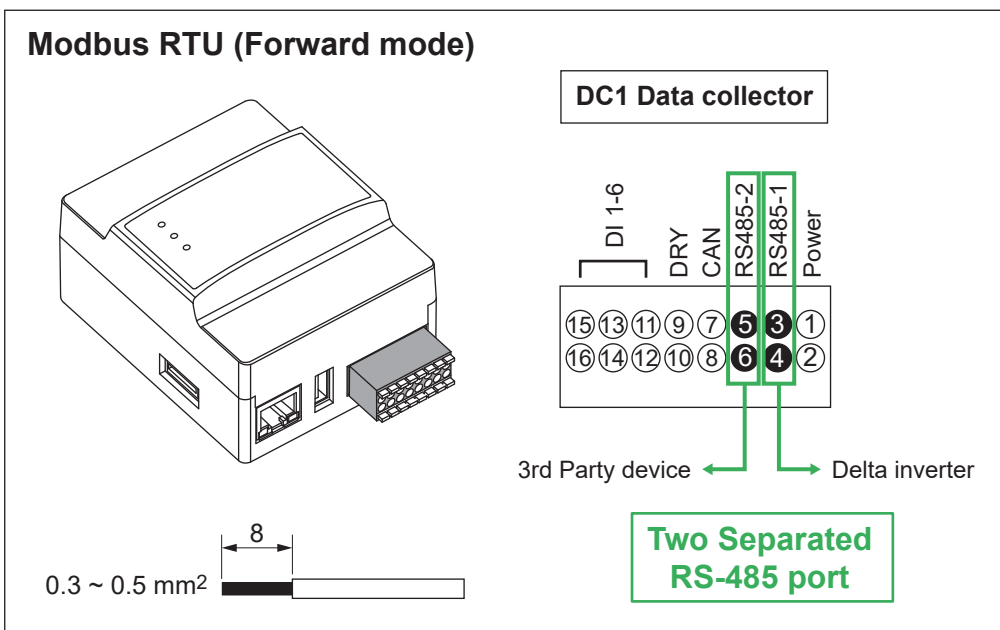
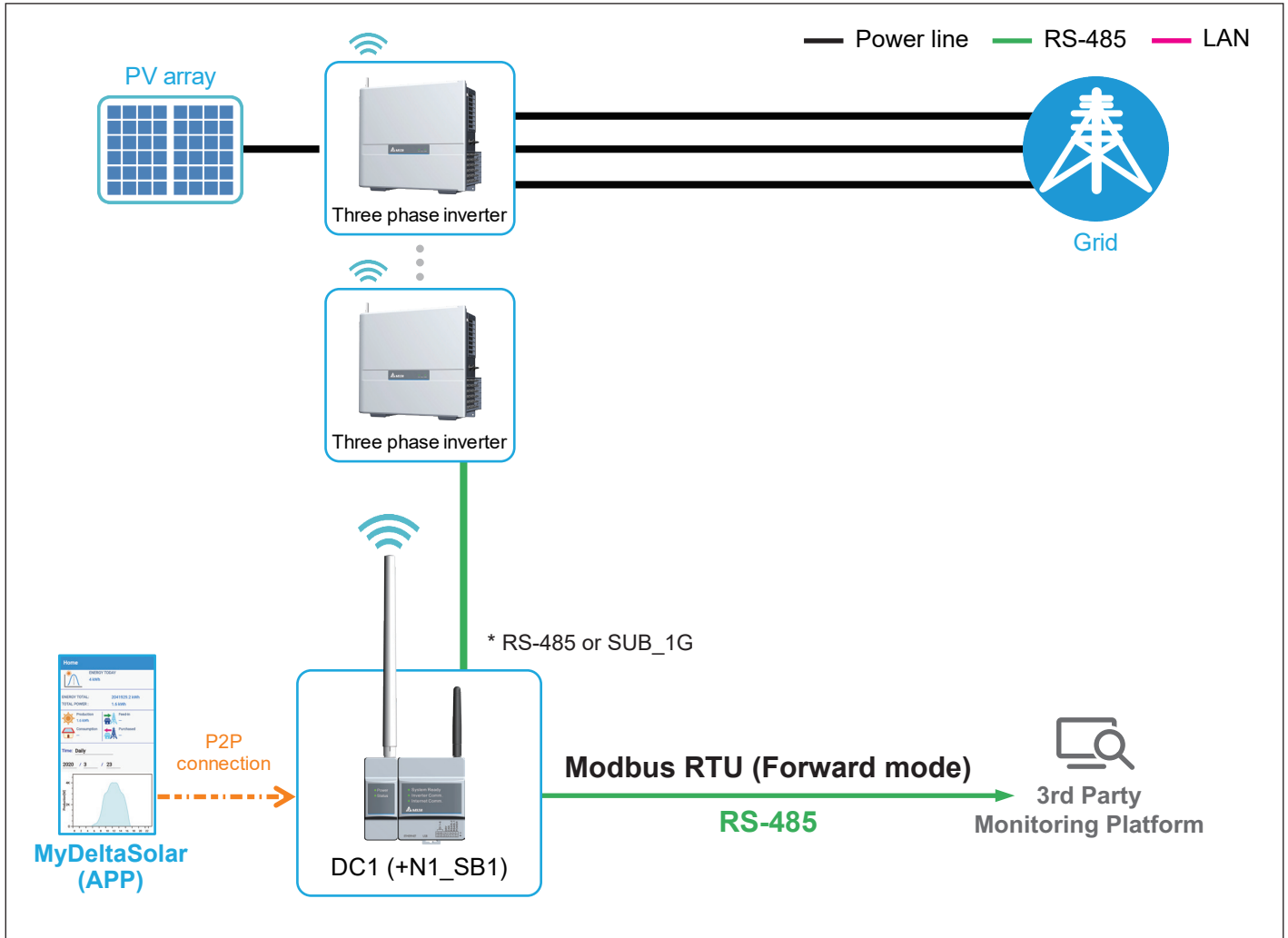

ATTENTION



- When forward mode is enable, DC1 will not able to deliver monitoring data to cloud and APP.

For details, please go to the following link to refer to the setting method manual.

MyDeltaSolar (APP) Operation and Installation Manual:

- Mobile App > MyDeltaSolar APP Operation Manual



https://mydeltasolar.deltaww.com/?p=product_manual

4. Specifications

ELECTRONIC SPEC		PPM DC1_100
Operating voltage range	9Vdc ~ 25Vdc (power port, can be supplied from inverter)	
Max. Power Consumption	5 Watt	
COMMUNICATION		
Wired	RS-485/ Ethernet	
Wireless	Internal Wi-Fi Module 802.11a/b/g/n	
REGULATION		
Safety Standard	EN 61010-1, CE compliance	
Emission (EMI)	EN 300 328, LP0002, Part 15C, Telec T66, KC	
Immunity(EMS)	EN 301 489-1/-17, EN 55024, EN 55032, FCC Part 15B	
CONNECTION		
I/O Port	2 pin terminal block for Power Port 4 pin terminal block for RS-485 2 pin terminal block for Can Bus 2 pin terminal block for Dry Contact 6 pin terminal block for digital inputs RJ-45 connector for Ethernet USB Port for data storage	
GENERAL INFORMATION		
LED Display	System Ready, Inverter Comm., Internet Comm.	
Operation temperature	-25°C ~ 60°C	
Relative humidity	30% ~ 85%	
Dimension (WxHxD)	72 x 90 x 55 mm	
Weight	160g (with Wi-Fi antenna)	

DC1 Functions

- **Data monitoring:**
Able to monitoring data from inverter to cloud or 3rd party monitoring system.
- **Connection & Grid setting :**
Support initial or function setting for inverter.
- **Firmware Update:**
Available to update FW by APP or USB for inverter and DC1 itself.
- **BACKUP/RESTORE:**
Backup the connection setting of DC1, after replacement of DC1 just need to restore the data back no need to set from the beginning.
- **REPLACE INVERTER:**
This function support change connection setting of DC1, after replace the inverter with new one.
- **DRM0 (Digital input) :**
This function can set inverters to specific power limit by shorten the corresponding connections.
- **PARTIAL/ZERO EXPORT:**
This function support dynamic output control application.
- **DRY CONTACT :**
When enable this function, the dry contact relay inside DC1 will close to trigger external device.
- **PHASE INTERLOCK:**
Only for AU market, turn on when needed. If one of the inverter lose communication with DC1, other inverter will also remote off.



MyDeltaSolar(APP) Operation Manual: Mobile App > MyDeltaSolar(APP) Operation Manual
https://mydeltasolar.deltaww.com/?p=product_manual



5. When Something Seems Wrong (Troubleshooting)

5.1. Error Displays



When a problem occurs, confirm the Error message from the [ERROR EVENTS LOG] page of [History].



Details can be verified in the “ERROR EVENTS LOG” pages.
Refer to the Manual of the Inverter for details on the error codes.

5.2.Troubleshooting

Responsive actions that should be taken in cases where the following symptoms occur are described.

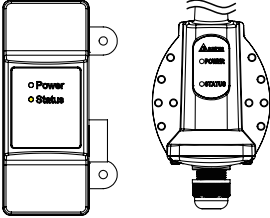
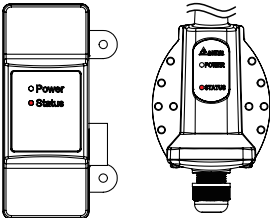
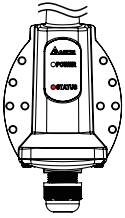
Symptom	Verification details	Responsive action
 <p>System ready light is red</p>	DC1 is booting	Please wait two minutes for the boot to complete
 <p>Inverter comm light is continuously flashing green light</p>	DC1 is Searching or Setting inverters.	Please wait for 2-10 minutes for Inverter to search or set up.
 <p>Internet light constant</p>	DC1 does not connect to internet	Please go to the NETWORK page to set network. For detailed setting process, please refer to APP manual.
 <p>The LED Light of 'Status' flashes slow and changing color between green and yellow</p>	N1 does not connect to Data Collector N2 does not connect to Inverter	Please confirm if N1 is assembled with Data Collector/ Please confirm if N2 is adapted to Inverter.
 <p>The LED Light of 'Status' turns red and slow flashing</p>	N1 or N2 is booting	Please wait a minutes for the boot to complete.
 <p>The LED Light of 'Status' turns red and fast flashing</p>	Initialize N2's RF module failed when connecting to an inverter.	Please confirm if there is a connection between N2 and Inverter. if not, refer the figure in Chapter 2 and connect each wire to the communication card of the Inverter correctly.

Appendix - PPM N1_SB1

1. Functions of Parts

	Part	Function
①	Antenna	SUB_1G Signal
②	External Comm. Connector	Connection to Data Collector
③	Fixed Point	Fix with Data Collector
④	Power LED	Power ON/OFF
⑤	SUB_1G LED	SUB_1G status
⑥	Reset Button	Reset to Default

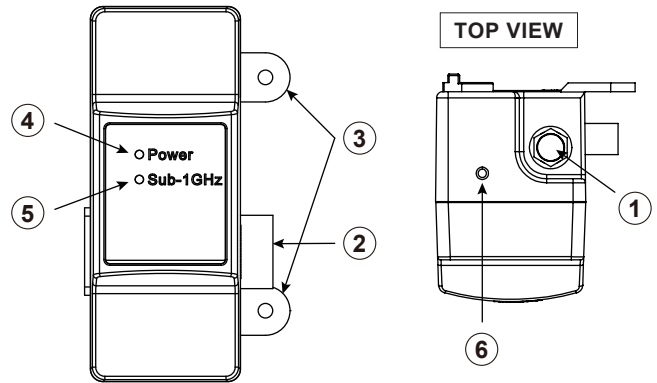

2. SUB_1G Antenna

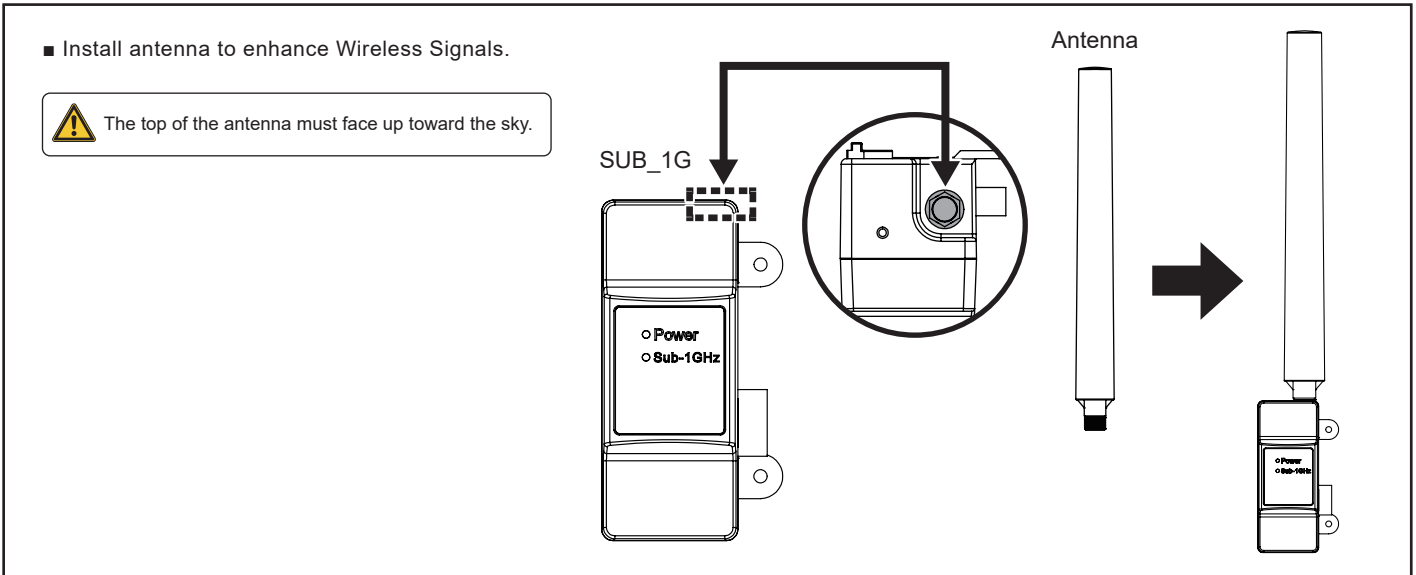

3. LED Description

Status	Red LED	Yellow LED	Green LED	Description
Upgrade N1	Slow Flash	OFF	Slow Flash	Update N1 card.
Upgrade Module	Slow Flash	Slow Flash	OFF	Update RF module.
No Host	OFF	Slow Flash	Slow Flash	No back-end devices are connected.
Module Not Ready	Slow Flash	OFF	OFF	Waiting for module initialization.
Ext. Idle	OFF	ON	OFF	No Ext. data transmission for more than 300 seconds.
Int. Idle	OFF	Slow Flash	OFF	No Int. data transmission for more than 600 seconds.
Normal	OFF	OFF	ON	Connecting.

Power	Light Green LED		Description
	ON		When the device is receiving power.
	OFF		Powered off.

Reset Button	Red LED	Yellow LED	Green LED	Description
Push 5~10s	ON	Slow Flash	OFF	Reset RF.
Push 15~20s	ON	Fast Flash	OFF	Reset RF & Freq. = Default Band.
Others	ON	OFF	OFF	Invalid operation.

4. Specifications

ELECTRONIC SPEC	PPM N1_SB1
Operating voltage	5 Vdc (supply from DC1)
Max. Power Consumption	1 Watt
COMMUNICATION	
Wired	RS-485
Wireless	SUB_1G
REGULATION	
Safety Standard	EN 61010-1, CE compliance
Emission (EMI)	EN 300 220 (below 1G), EN 50385, LP0002, Part 15C, Telec T66, KC, Anatel, WPC
Immunity(EMS)	EN 301 489-1/-3, EN 55024, EN 55032, FCC Part 15B
CONNECTION	
I/O Port	6 pin terminal block (2 x RS-485, 4 x GPIO)
GENERAL INFORMATION	
LED Display	Power, SUB_1GHz
Operation temperature	-25°C ~ 60°C
Relative humidity	30% ~ 85%
Dimension (WxHxD)	48 x 309 x 55 mm
Weight	100g

5. Dimensions

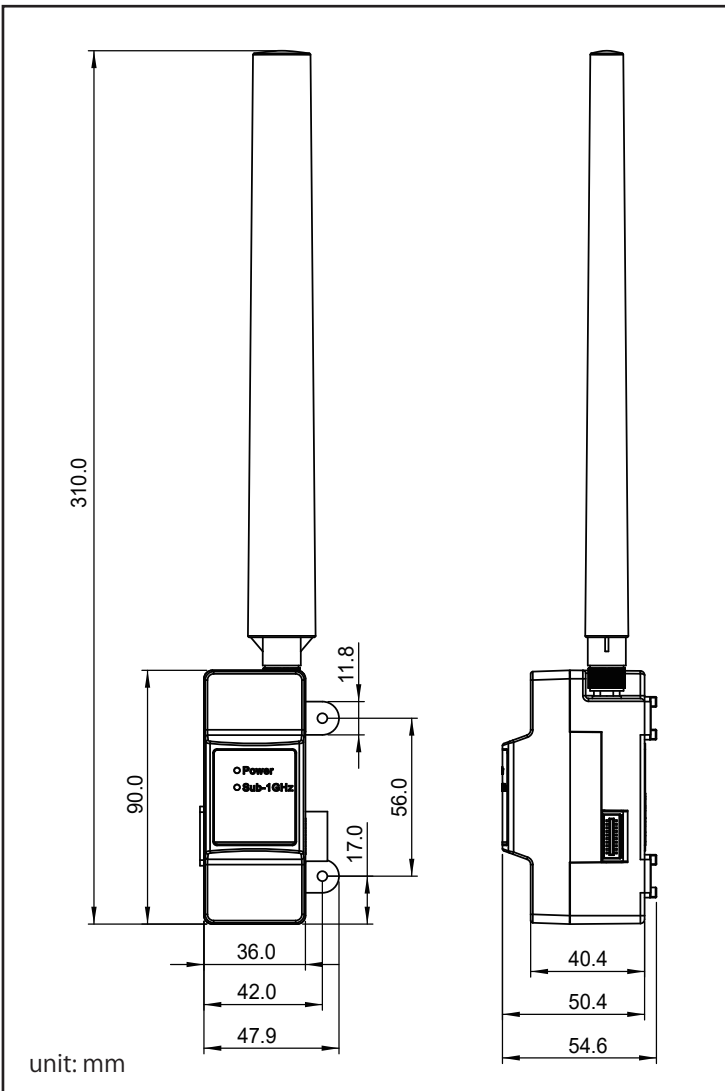

6. SUB_1G (N1) Module

Name	Explanation
Network standard support	FCC/CE/TELEC/NCC
Data rates	5860bps (BW: 500kHz) 2930bps (BW: 250kHz)
Modulation techniques	FSK/OOK
Bandwidth	FCC: 500kHz CE: 250kHz TELEC: 500kHz NCC: 500kHz

7. Installation Diagram

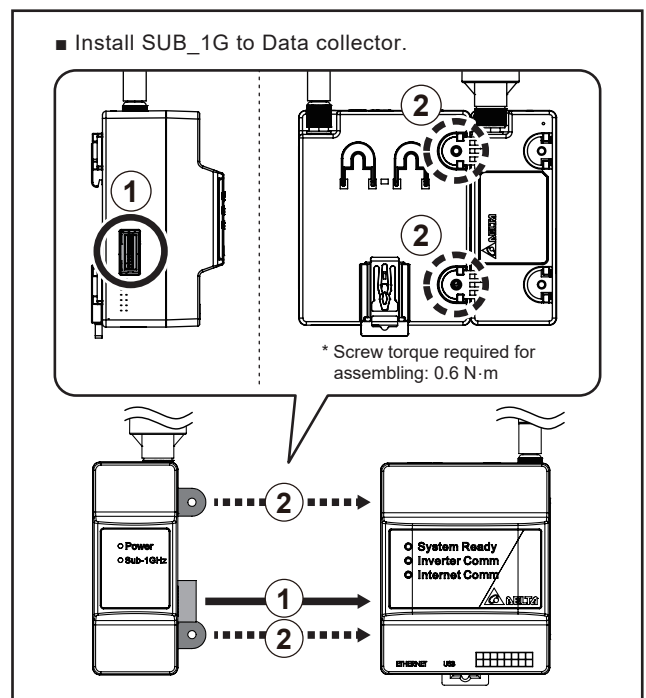

Appendix - PPM N2_SB1

1. Functions of Parts

	Part	Function
①	Antenna	SUB_1G Signal
②	Fixed Point	Fix on inverter
③	Reset Button	Reset to default
④	Power LED	Power ON/OFF
⑤	Status LED	SUB_1G Status
⑥	Cable Gland	Avoid the moisture into machine

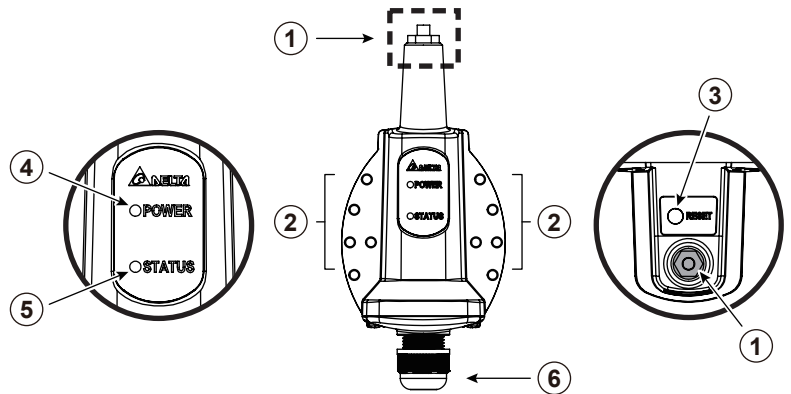

2. SUB_1G Antenna

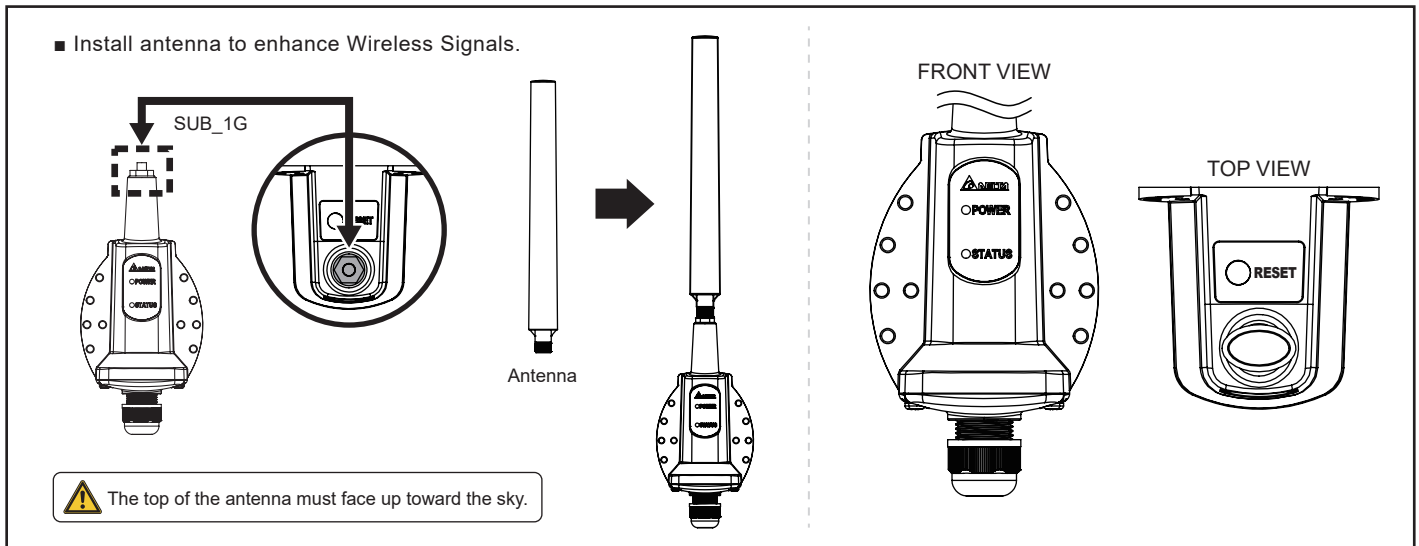

3. LED Description

STATUS	Red LED	Yellow LED	Green LED	Description
Upgrade N2	Slow Flash	OFF	Slow Flash	Update N2 card.
Upgrade Module	Slow Flash	Slow Flash	OFF	Update RF module.
No Host	OFF	Slow Flash	Slow Flash	No back-end devices are connected.
Module Not Ready	Slow Flash	OFF	OFF	Waiting for module initialization.
Module Init Fail	Fast Flash	OFF	OFF	Initialize RF module failure when connecting to inverter.
Ext. Idle	OFF	ON	OFF	No Ext. data transmission for more than 300 seconds.
Int. Idle	OFF	Slow Flash	OFF	No Int. data transmission for more than 600 seconds.
Data Transfer	OFF	OFF	Fast Flash	Data transfer in progress.
Normal	OFF	OFF	ON	Connecting.

POWER	Light Green LED		Description
		ON	When the device is receiving power.
		OFF	Powered off.

Reset Button	Red LED	Yellow LED	Green LED	Description
Push 5~10s	ON	Slow Flash	OFF	Reset RF.
Push 15~20s	ON	Fast Flash	OFF	Reset RF & Freq. = Default Band.
Others	ON	OFF	OFF	Invalid operation.

4. Specifications

ELECTRONIC SPEC		PPM N2_SB1
Operating voltage range	12 Vdc ~ 36 Vdc	
Max. Power Consumption	1 Watt	
COMMUNICATION		
Wired	RS-485	
Wireless	SUB_1G	
REGULATION		
Safety Standard	EN 61010-1, CE compliance	
Emission (EMI)	EN 300 220 (below 1G), EN 50385, LP0002, Part 15C, Telec T66, KC, Anatel, WPC	
Immunity(EMS)	EN 301 489-1/-3, EN 55024, EN 55032, FCC Part 15B	
CONNECTION		
I/O Port	2 pin terminal block for RS-485	
GENERAL INFORMATION		
LED Display	POWER, STATUS	
Operation temperature	-25°C ~ 60°C	
Relative humidity	30% ~ 85%	
Dimension (WxHxD)	78 x 396 x 72 mm	
Weight	150g	

5. Dimensions

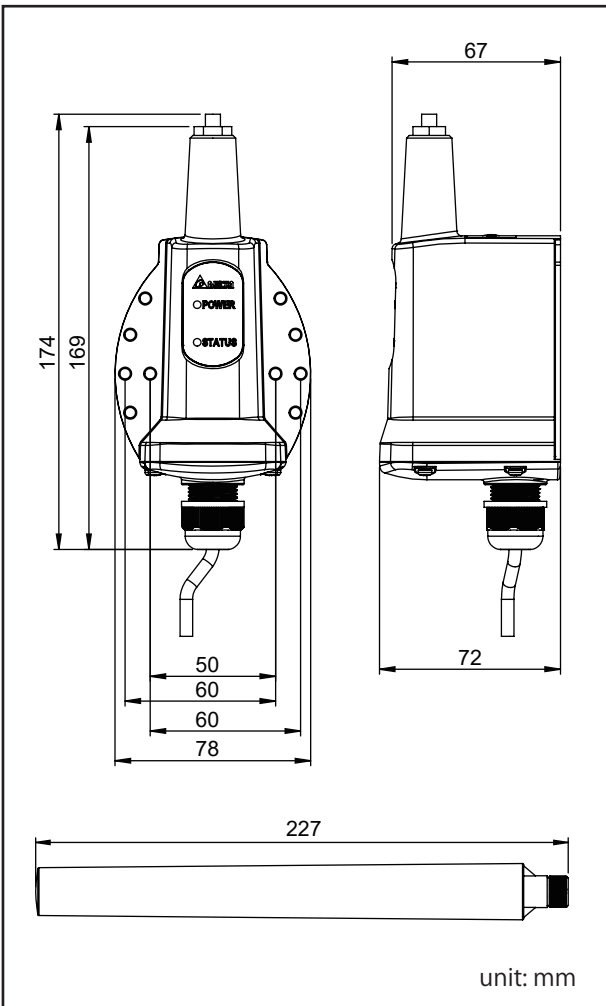

6. SUB_1G (N2) Module

Name	Explanation
Network standard support	FCC/CE/TELEC/NCC
Data rates	5860bps (BW: 500kHz) 2930bps (BW: 250kHz)
Modulation techniques	FSK/OOK
Bandwidth	FCC: 500kHz CE: 250kHz TELEC: 500kHz NCC: 500kHz

7. Installation & Communication Wiring

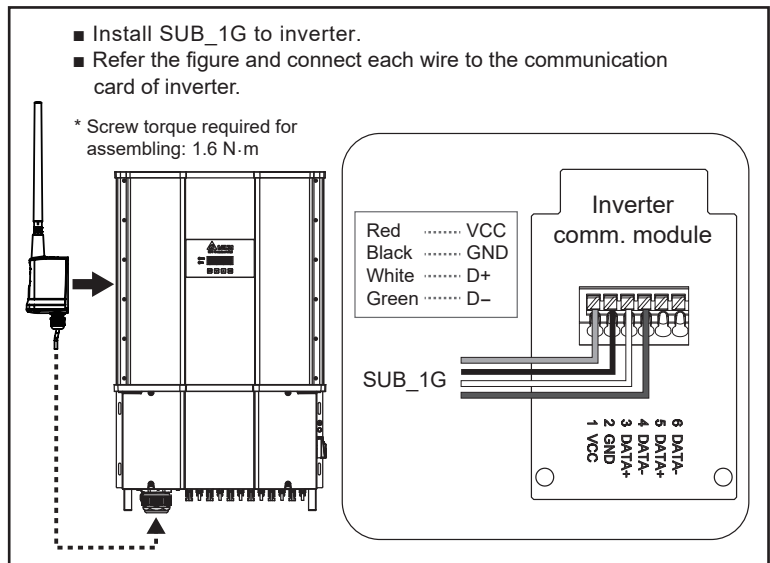

Appendix - PPM N2_WIFI

1. Functions of Parts

	Part	Function
①	Antenna	Wi-Fi Signal
②	Fixed Point	Fix on inverter
③	Reset Button	Reset to default
④	Power LED	Power ON/OFF
⑤	Status LED	Wi-Fi Status
⑥	Cable Gland	Avoid the moisture into machine

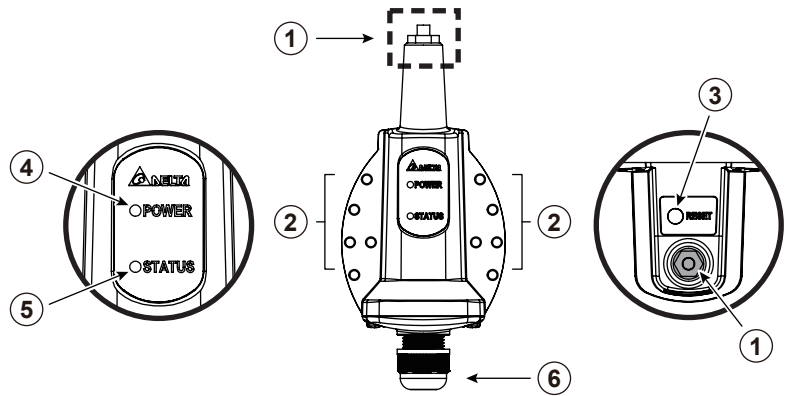

2. Wi-Fi Antenna

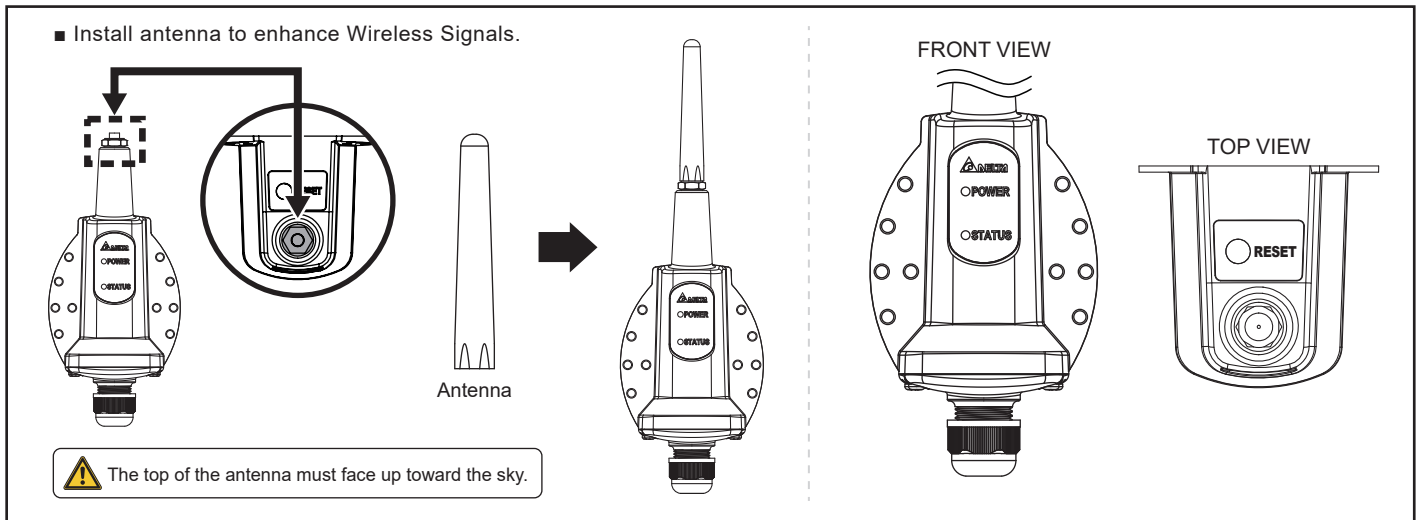

3. LED Description

	Action (Green LED)	Description
POWER	ON	When the device is receiving power.
	OFF	Powered off.

	Action (Green LED)	Description
STATUS	Flash : 3s On, 3s Off	Connected to WiFi router/DC1
	Flash : 3s Flash(100ms), 3s Off	Connected to both WiFi router/DC1 and mobile device
	Off	Not connected
	Steady On	Connected to mobile device
	Flash : 100ms On, 100ms Off	Connected to mobile device and transferring data
	Flash : 500ms On, 500ms Off	Reboot Wi-Fi (Press Button 3~10s)
	Flash : 1s On, 1s Off	Reset Password & Reset Wi-Fi Settings (Press Button 20~30s)

Reset Button	Wi-Fi LED Status	Description
Push 3s~10s	Wi-Fi LED flashing once every half a second	Reset Wi-Fi module
Push 10s~20s	No flash	No function
Push 20s~	Wi-Fi LED flashing once every one seconds	Reset Wi-Fi module, and Wi-Fi password returns to the default: DELTASOL

4. Specifications

ELECTRONIC SPEC		PPM N2_WIFI
Operating voltage range	12 Vdc ~ 36 Vdc	
Max. Power Consumption	3 Watt	
COMMUNICATION		
Wired	RS-485	
Wireless	Wi-Fi	
REGULATION		
Emission (EMI)	EN 300 220 (below 1G), EN 50385, LP0002, Part 15C, Telec T66, EN 300 328, LP0002, FCC Part15.247, KC	
CONNECTION		
I/O Port	2 pin terminal block for RS-485	
GENERAL INFORMATION		
LED Display	POWER, STATUS	
Operation temperature	-25°C ~ 60°C	
Relative humidity	30% ~ 85%	
Dimension (WxHxD)	78 x 246 x 72mm	
Weight	150g	

5. Dimensions

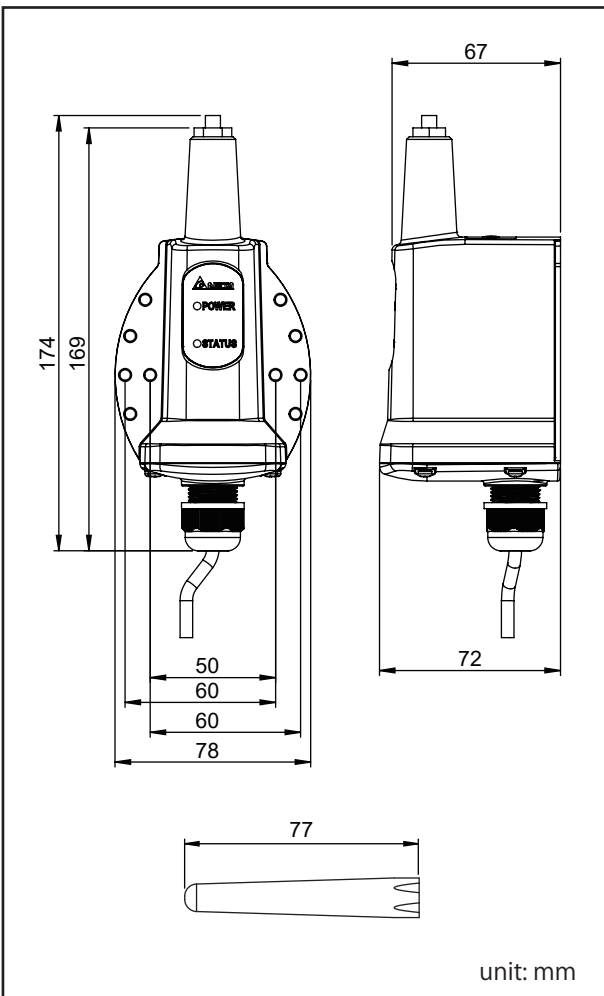

6. Wi-Fi Module

Name	Explanation
Wireless Protocols	IEEE 802.11b, 802.11g, 802.11n
WLAN Bandwidth	20 MHz / 40 MHz
WLAN Data Rates	802.11b: 1, 2, 5.5, 11 Mbps 802.11g: 6, 9, 12, 18, 24, 36, 48, 54 Mbps 802.11n: MCS0 to MCS7 with and without Short GI
WLAN Operating Frequency Range	2412 MHz – 2472 MHz
WLAN Modulation	OFDM with BPSK, QPSK, 16-QAM, and 64-QAM 802.11b with CCK and DSSS
WLAN Transmit Power	17 dBm
WLAN Receive	-97 dBm

7. Installation & Communication Wiring

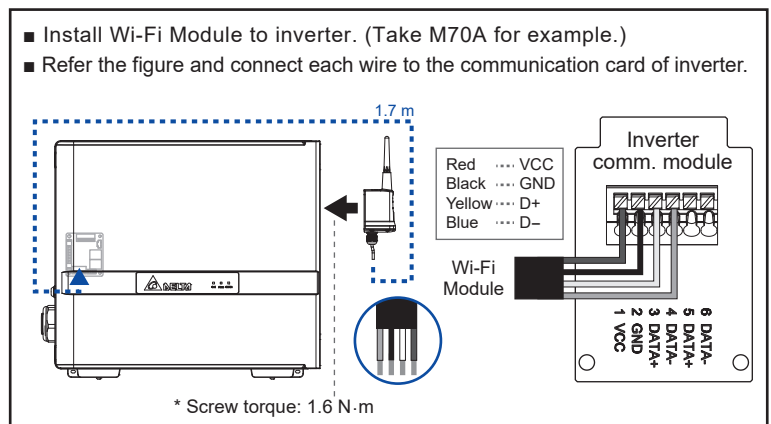

Appendix - PPM P1_120

1. Functions of Parts

A	Mains voltage connector block
B	CT wire connector
C	Connect with Data Collector
D	Meter status LED
E	Reset Button
F	RS-485 port & terminal resistor port

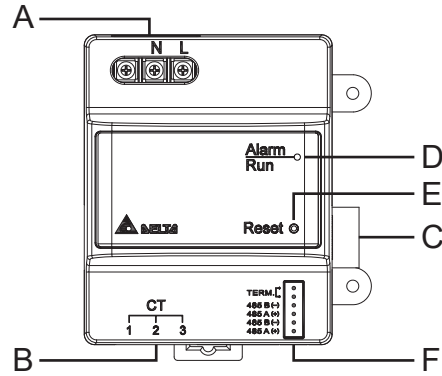

2. LED Description

LED	Status	Explanation
Red	On	Hardware failure
Red	Blink	No communication from other device
Green	On	Normal
Green	Blink	Wait for connection

3. Specifications

ELECTRONIC SPEC	PPM P1_120
Communication	RS-485
Input voltage range	85 Vac - 264 Vac
Nominal voltage	230 Vac
Frequency	50Hz / 60Hz \pm 5%
Max. Self - consumption	2 W
Max. consumption - With Data Collector	7 W
Current transducer	120 A (standard), 300 A (optional)
Sensing aperture dimension	Φ 15.0 mm
Torque for screw terminal	0.98 Nm
Certificate	EN61010-1, CE Compliance, EN61326
Weight (without current transformer)	170g
Dimensions (W / H / D)	72 mm x 90 mm x 55 mm
Ambient temperature in operation	- 20°C to 60°C
Ambient temperature during transport / storage	- 30°C to 70°C
Operating humidity	30% to 85% (non-condensing)
Storage humidity	30% to 85% (non-condensing)

Appendix - PPM P3_120

1. Functions of Parts

A	Mains voltage connector block
B	CT wire connector
C	Connect with Data Collector
D	Meter status LED
E	Reset Button
F	RS-485 port & terminal resistor port

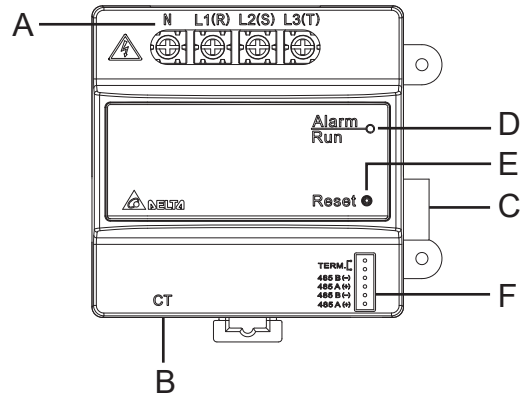

2. LED Description

LED	Status	Explanation
Red	On	Hardware failure
Red	Blink	No communication from other device
Green	On	Normal
Green	Blink	Wait for connection

3. Specifications

ELECTRONIC SPEC	PPM P3_120
Communication	RS-485
Input voltage range	95 Vac - 277 Vac (L-N)
Nominal voltage	3P4W 220 Vac, 3P3W 380 Vac
Frequency	50Hz / 60Hz ± 5%
Max. Self - consumption	3 W
Max. consumption - With Data Collector	8 W
Current transducer	120 A (standard), 300 A (optional)
Sensing aperture dimension	Ø15.0 mm
Torque for screw terminal	1 Nm
Certificate	EN61010-1, CE Compliance, EN61326
Weight (without current transformer)	215 g
Dimensions (W / H / D)	90 mm x 90 mm x 55 mm
Ambient temperature in operation	- 20°C to 60°C
Ambient temperature during transport / storage	- 30°C to 70°C
Operating humidity	30% to 85% (non-condensing)
Storage humidity	30% to 85% (non-condensing)

