

DC-DC Converters

For powering 13 V systems in industrial electric vehicles

MOOV^{on}

| **Datasheet**



Industrial



Logistics



Utility
Vehicles



Features

- CE mark and UL recognized
- Ingress Protection: IP69K water / dust proof
- Compliant to salt spray standard EN 60068-2-11
- Wide input voltage range:
 - 24 V to 36 V battery models: 16.8 V_{DC} to 43.5 V_{DC}
 - 48 V to 100 V battery models: 33.6 V_{DC} to 120 V_{DC}
- Output short circuit protection
- Input reverse polarity protection
- Operating temperature range: -35 °C to +85 °C

DC Input (X1)		48 V – 100 V 600 W	48 V – 100 V 400 W	24 V – 36 V 400 W
Input voltage range		33.6 V – 120 V		16.8 V – 43.5 V
Extended operating range ¹		24 V - 33.6 V		12 V - 16.8 V 43.5 V - 56 V
Maximum input current	at min. V _{nom}	14.7 A	9.4 A	19.0 A
	at max. V _{nom}	8.8 A	5.7 A	12.5 A
No load input current ²		< 75 mA	< 45 mA	< 60 mA
Inrush Pulse		< 1.5 A ² s		

DC Output (X2)		48 V – 100 V 600 W	48 V – 100 V 400 W	24 V – 36 V 400 W
Output Power		600 W	400 W	
Nominal output voltage		13 V		
Minimum output voltage ³		12.5 V		
Maximum output current		46.2 A	30.8 A	
Start-up time under full load ⁴		< 500 ms		
Noise (peak to peak)		< 0.5 V		
Typical Efficiency ⁵		91%	89%	86%
Line regulation ³		±1%		
Line regulation (maximum) ⁶		±3%		
Load regulation		±4%		
Load regulation response ⁷		100 ms		
Step load regulation ⁸		±10%	±5%	

1 For a maximum of 5 minutes at nominal output power

2 At nominal battery voltage

3 At input voltage range. When operating in the extended lower input range the minimum output voltage is 12V

4 Measured with a resistive load

5 For 50% to 100% load

6 At extended input voltage range

7 Slew rate 1 A/μs

8 Load step: 10% → 90%, 90% → 10%

Environmental conditions

Test	In Accordance with standard	Test Details
Temperature change	EN 60068-2-14	Duration: 240 h and 20 cycles minimum. Cycle between -35 °C and 85 °C
Constant warm temperature	EN 60068-2-2	Duration: 96h Test temperature: 85 °C
Temperature shock	EN 60068-2-14	Duration: 20 cycles Operation mode: In operation Test temperature: 85 °C Test duration: 1 h fully tempered + 15 minutes Transfer duration: < 5 s Test medium: Water 0 °C, 5% dissolved salt content Time under water: 5 minutes Water volumes: At least 5 times the component volume No water ingress
Humidity/Heat cyclic	EN 60068-2-30	Max air temperature: 55 °C Number of cycles: 6 Operation mode: 1 h in operation 1 h without function Air humidity: 93% Cycles duration: 24 h Temperature change ≥ 5 K/min Minimum air temperature 25 °C
Vibrations, sinusoidal	EN 60068-2-6	Load: 10 g Frequency range: (10-500) Hz Length of time subject to load: 3 axes, 9 hr (50 cycles) per axis Form: sinusoidal Operation mode: operational
Continuous shock	EN 60068-2-29	Shock load: 10 g Duration: 16 ms Number of impacts: 10000 shocks
Shocks	EN 60068-2-27	Shock load: 30 g Duration: 6 ms 3 shocks per direction, 6 directions
Salt spray	ISO 9227 (NSS) EN 60068-2-11	35 °C, 96 hours
Ingress Protection	IP69K	Per ISO 20653
Operating temperature ¹	-	-35 °C to +85 °C (-22 °F to +185 °F)
Storage temperature	-	-40 °C to +85 °C (-40 °F to +185 °F)

¹ When mounted to a cooling plate that must not exceed 70 °C

Protection and Reliability	48 V – 100 V	48 V – 100 V	24 V – 36 V
	600 W	400 W	400 W
Over current protection	49.0 A	40.5 A	
Over temperature protection	Yes		
Short circuit protection	Yes		
Reverse input protection	-120 V		-50 V
No spark on contact	Yes		
MTBF ¹	1,000,000 h	1,100,000 h	
Insulation voltage			
DC Input - DC Output	1.77kV _{AC} / 2.5kV _{DC}		
DC Input – Housing	1.77kV _{AC} / 2.5kV _{DC}		
DC Output - Housing	1.2kV _{AC} / 1.7kV _{DC}		

Mechanical Data	48 V – 100 V	48 V – 100 V	24 V – 36 V
	600 W	400 W	400 W
Dimensions (W x H x D)	115 x 71 x 203 mm (4.5 x 2.8 x 8 inch)	115 x 61 x 203 mm (4.5 x 2.4 x 8 inch)	
Weight	2.1 Kg (4.63 lb)	1.6 Kg (3.53 lb)	1.7Kg (3.75 lb)
Case material	Aluminium		
Cooling	Conduction via heatsinking		

Approvals and Compliance	
Safety marks	cUR _{US} , CE
Safety ²	IEC 62368-1
EMC ³	EN 12895, CISPR 25/EN 55025 EN 61000-4-4, ISO 10605, ISO 11452-2, ISO 11452-4, ISO 11452-8

Connector pin assignments				
	Connector	Input/output	Pin	Assignment
	X1	Input	1	Positive (+)
			2	0 V (GND)
	X2	Output	1	Positive (+)
			2	0 V (GND)

Example Mating Connectors ⁴	
X1	FEP 42122900
X2	FEP 42161000

1 Telcordia SR-332 at 50 °C (122 °F)

2 Designed to allow industrial truck approval to UL 583 and EN 1175

3 EMC suitability must be evaluated in the end-use application

4 It is the user's responsibility to select connector material based on the safety standard they are aiming to comply with.

Dimensional drawing

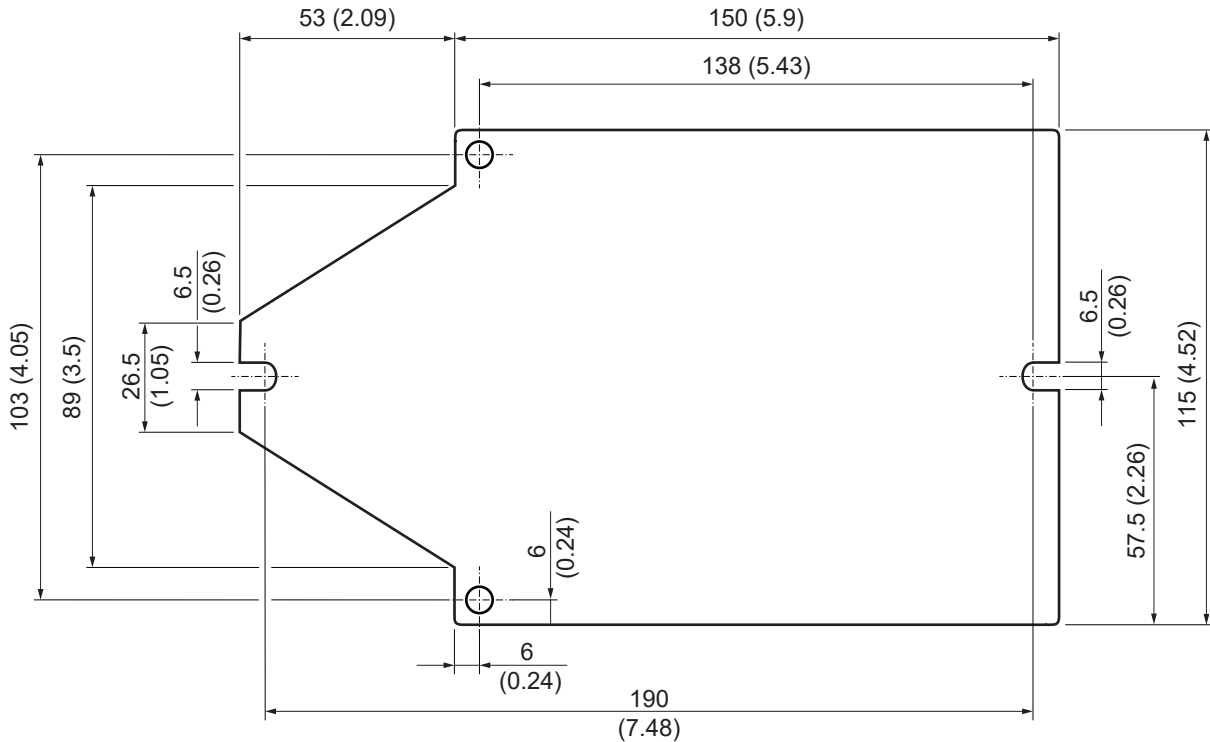

Dimensions in mm (inch)

Mounting instructions

Make sure to install the DC-DC converter on a metal cooling surface, whose temperature should not exceed +70 °C (+158 °F). Use the provided gap pad between the DC-DC converter and the metal cooling surface in order to maintain good thermal contact. This avoids over heating of the DC-DC converter. Use M6 stainless steel screws with a minimum length of 12 mm and a maximum head diameter of 10.5 mm. The recommended torque is 4.6 Nm (40.7 in-lb). The correct torque should be established for each use case.

Parallel operation

Two or more DC-DC converters can be connected in parallel. Droop current sharing method is adopted to aid current sharing but good current sharing is only possible with very similar output impedance and with the output voltages closely aligned. Current sharing suitability must be fully evaluated in the end-use application.

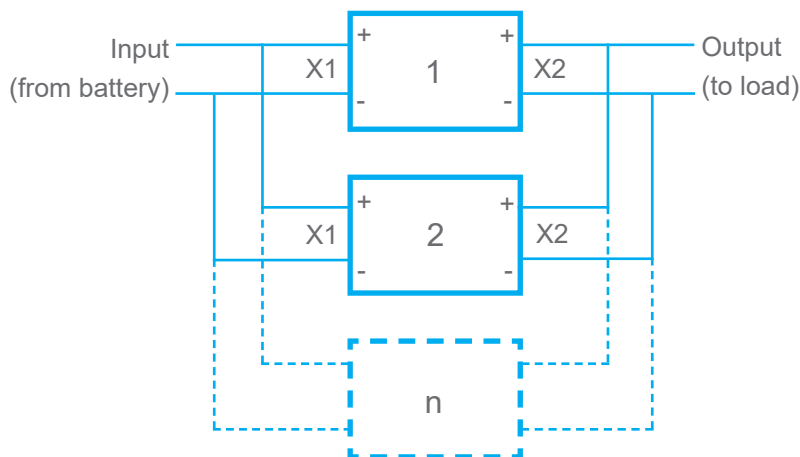



More information

Delta Energy Systems (Germany) GmbH

Tscheulinstrasse 21, 79331 Teningen

E-mail: IEV.sales@deltaww.com

www.deltaww.com

August 2024 Revision 1.4

© Copyright – Delta Energy Systems (Germany) GmbH – All rights reserved. All information and specifications can be modified without prior notice.