

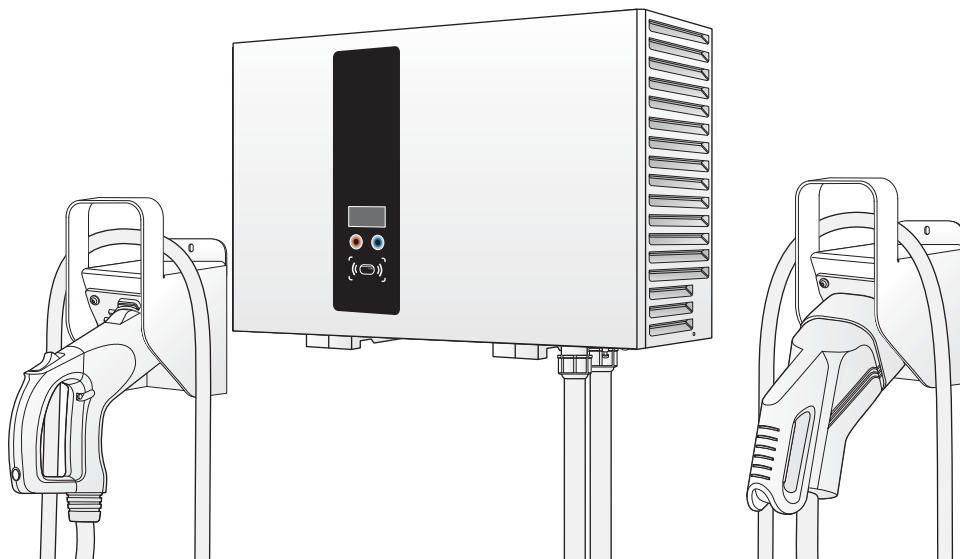

DC Wallbox Charger

Installation and Operation Manual



Version: 1.0.0

TABLE OF CONTENTS

Introduction	1
Features	1
Applications	2
Important Safety and Wiring Instructions	3
Safety and Compliance	3
Service Wiring	4
Before Installation	6
Safety Requirements	6
Accessory Kit	6
Recommended Tools	7
Installing the DC Wallbox Charger	8
Making the Connection	12
Operation	20
System Configuration	22
3G Configuration	23
Firmware Update	23
Maintenance	24
System Code.	25
Specifications	29

Conventions

General Conventions

The following conventions are used in this manual:



Note:

Indicates additional information that is relevant to the current process or procedure.



WARNING!

Warning information appears before the text it references to emphasize that the content may prevent damage to the device or equipment.



CAUTION!

CAUTIONS APPEAR BEFORE THE TEXT IT REFERENCES. CAUTIONS APPEAR IN CAPITAL LETTERS TO EMPHASIZE THAT THE MESSAGE CONTAINS VITAL HEALTH AND SAFETY INFORMATION.

Typographical Conventions

The following typographical conventions are used in this document:

Italics

Indicates book titles, directory names, file names, path names, and program/process names.

Constant width

Indicates computer output shown on a computer screen, including menus, prompts, responses to input, and error messages.

Constant width bold

Indicates commands or information literally entered by a user on the computer. Variables contained within user input are shown in angle brackets (< >).

Bold italics.

Indicates keyboard keys that are pressed by the user.

Copyright

The ownership and all intellectual property rights of this Installation and Operation Manual (this “Manual”), including but not limited to the content, data and figures contained herein are vested by Delta Electronics, Inc. (“Delta”). The Manual can only be applied to operation or use of the product. Any disposition, duplication, dissemination, reproduction, modification, translation, extraction or any other usage to the Manual is prohibited without obtaining Delta’s prior written permission. As the product will be developed and improved continuously, Delta may modify or update the Manual from time to time without any notice. Delta will do its best efforts to keep the Manual updated and maintain the accuracy of the Manual. Delta disclaims any kinds or forms of warranty, guarantee or undertaking, either expressly or implicitly, including but not limited to the completeness, accuracy, non-infringement, merchantability or fitness for particular purpose or usage.

Copyright © Delta Electronics, Inc. All Rights Reserved.

Introduction

The DC Wallbox charger is the top choice for powering battery electric vehicles (BEV) and plug-in electric vehicles (PHEV) today. It is designed for quick charging in both public and private locations, such as retail and commercial parking spaces, fleet charging stations, highway service areas, workplaces, residences, etc.

The DC Wallbox charger has the advantage of easy installation. The wall-mounting design and pluggable power modules allow for flexible and cost-effective installation at various types of locations. The DC Wallbox charger also features network communication capability; it is able to connect with remote network systems and provide drivers of electric cars real-time information, such as the locations of charging stations, charging progress information and billing information. DC Wallbox charger has a clear user interface with function buttons, a power supply safety system and excellent waterproof and dust-proof technology to provide the best choice for outdoor environments. It can also integrate with renewable energy systems, such as solar power and wind power technology, to provide the most energy saving infrastructure for EV system development.

Features

- Wall-mount design and pluggable power modules make installation easy and flexible.
- Offers customers the convenience of full start and stop charging control from an authorized RFID smart card.
- Built according to latest industry standards for DC charging.
- Carries an outdoor rating capable of withstanding solid and liquid intrusions in outdoor settings, making the unit more stable and highly reliable.
- Provides a high-contrast, OLED screen interface with multi-function buttons.

Applications

- Public and private parking areas
- Community parking areas
- Parking areas of hotels, supermarkets and shopping malls
- Workplace parking areas
- Charging stations
- Highway rest areas

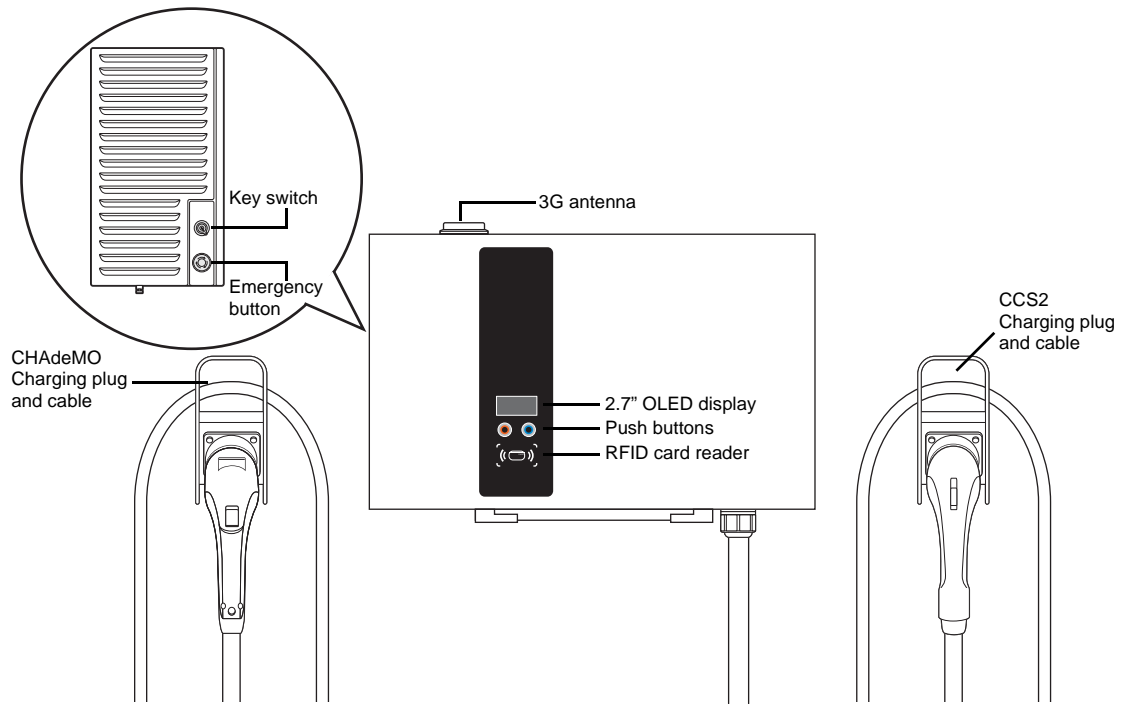

Important Safety and Wiring Instructions

Safety and Compliance

- Read the manual before installation or usage of device.
- Do not put tools, material or body parts into the electric vehicle connector.
- Do not use the DC Wallbox charger if the cabinet, power cord or charging cable are frayed, have broken insulation or show any other signs of damage.
- Do not install or use the DC Wallbox charger if the enclosure is broken, cracked, open or shows any other indications of damage.
- The DC Wallbox charger should be installed only by a qualified technician.
- Make sure that the materials used and the installation procedures follow local building codes and safety standards.
- The information provided in this manual in no way exempts the user of responsibility to follow all applicable codes or safety standards.
- The manufacturer is not responsible for physical injury, damage to property or damage to equipment caused by the installation of this device.
- This document provides instructions for the DC Wallbox charger and should not be used for any other product. Before installation or use of this product, you should review this manual carefully and consult with a licensed contractor, licensed electrician or trained installation expert to make sure of compliance with local building codes and safety standards.

Service Wiring

Ground Connection

Always connect the Neutral at the service to Earth Ground. If ground is not provided by the electrical service, a grounding stake must be installed nearby. The grounding stake must be connected to the ground bar in the main breaker panel, and the Neutral must be connected to Ground at that point.

380V - 415V Three-Phase



WARNING!

This feed is from a y-connection power grid, and the DC Wallbox can connect to L1, L2 or L3, and to neutral. Earth ground must be connected to neutral at only one point, usually at the breaker panel.

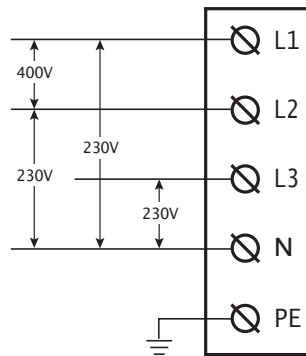

Figure 1. 380V - 415V Three-Phase Wiring Connection

200V - 230V Three-Phase



WARNING!

This feed is from a Delta-connection power grid, and the DC Wallbox can connect to L1, L2 or L3, and to neutral. Earth ground must be connected to neutral at only one point, usually at the breaker panel.

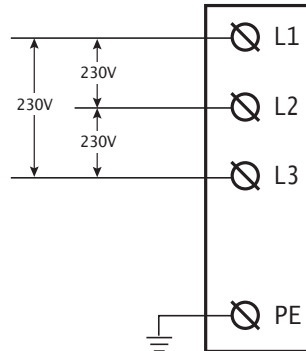

Figure 2. 200V - 230V Three-Phase Wiring Connection



WARNING!

High leakage current.
Earth connection essential before connecting supply.

Before Installation

Safety Requirements

- Be sure to preview the standard operating procedures (SOP) and ensure local building and electrical codes are reviewed before installing the DC Wallbox charger.
- The DC Wallbox charger should be installed by a qualified technician according to the instruction manual and local safety regulations.
- Use appropriate protection when connecting to the main power distribution cable.
- Disconnect switch for each ungrounded conductor of ac input shall be provided by others in accordance with the IEC61851-1.
- For three-phase four-wire 380Vac-415Vac input, type C or D breaker with type A 4-pole 30mA RCD in the upstream panel should be installed, and the rating current of the breaker should be 50A.
- For three-phase three-wire 200Vac-230Vac input, type C or D breaker with type A 3-pole 30mA RCD in the upstream panel should be installed, and the rating current of the breaker should be 100A.

Accessory Kit

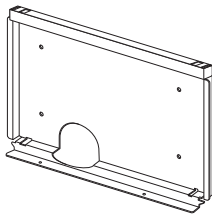

Mounting bracket x 1

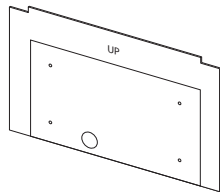

Mounting template x 1

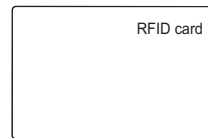

RFID cards x 2



Keys x 2

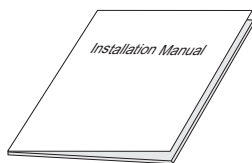

User manual x 1

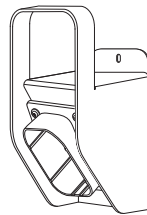

CCS2 plug holder x 1

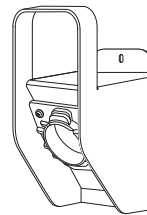

CHAdeMO plug holder x 1 (dual output model only)



Bag of bracket screws x 2
(SCREW M M6*1*8 PAN TORX SUS NL)



Bag of grounding screw x 1
(SCREW M M6*1*12 HEXH C S+P S20C ZN-NI)

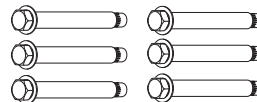

Bag of expansion bolts x 6 (+2 for dual output model)
(ANCHOR SUS 16*50.8 PICKLING)

Recommended Tools

The following tools are recommended for the DC Wallbox charger installation:

- (1x) Voltmeter or digital multi-meter
- (1x) Water level
- (1x) Hammer
- (1x) Concrete drilling machine
- (1x) Wire cutters/strippers
- (1x) Torx[®] Tamper-Resistant T15 and T20 screwdriver
- (1x) No.8 Flathead screwdriver and socket wrench
- (1x) No.6 Flathead screwdriver
- (1x) No.2 Philips screw driver
- (1x) No.3 Philips screw driver
- (1x) M50 conduit hub, conduit and wrench for main power wires
- (1x) M25 conduit hub, conduit and wrench for Ethernet
- (4x) Ring terminal RNB14-6 for L1/L2/L3/N wire (14mm² copper wire) in models with 380V-415V three-phase input
- (3x) Ring terminal RNB38-6 for L1/L2/L3 wire (38mm² copper wire) in models with 200V-230V three-phase input
- (1x) Ring terminal RNB14-6 for PE/ground wire (14mm² copper wire)

Important Safety Instructions.

Save these Instructions.

- The DC Wallbox charger should be installed only by a licensed contractor, and/or a licensed electrician in accordance with all applicable state, local and national electrical codes and standards.
- Before installing the DC Wallbox charger, review this manual carefully and consult with a licensed contractor, licensed electrician and trained installation expert to ensure compliance with local building practices, climate conditions, safety standards and state and local codes.



WARNING!

Danger of electrical shock or injury. Turn off power at the panel board or load center before working inside the equipment or removing any component. Do not remove circuit protective devices or any other component until the power is turned off.



CAUTION!

TO AVOID DAMAGE TO THE CHARGER OR PERSONAL INJURY, MAKE SURE THE INSTALLATION LOCATION IS ABLE TO SUPPORT THE WEIGHT OF THE DC WALLBOX CHARGER.

Installing the DC Wallbox Charger

Preparation

1. Release the screws on the crate (two sides) with a No. 8 socket wrench.
2. Open top lid of plywood crate.

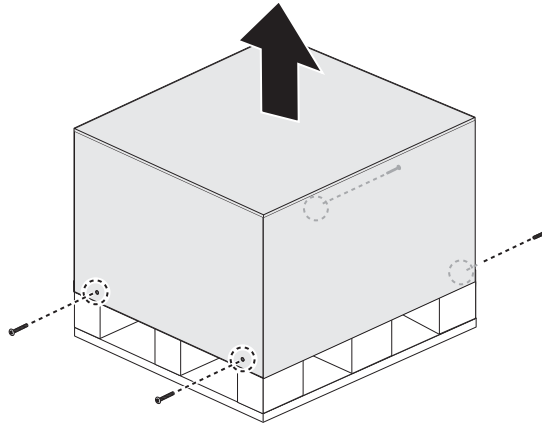

3. Take out mounting template and cut off the cable ties to move the charging plug.

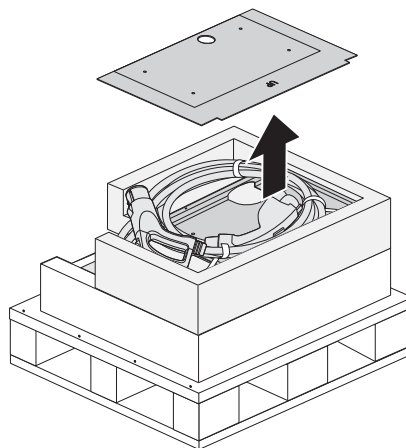

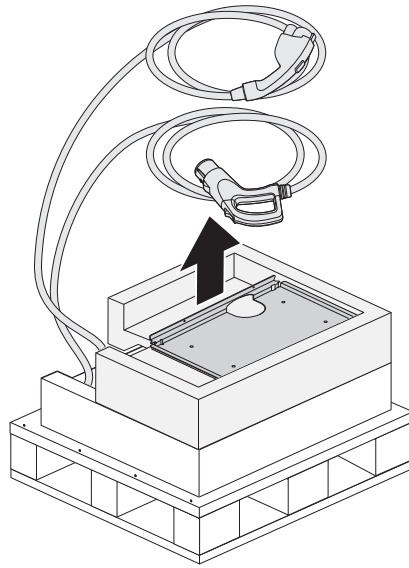

4. Remove top foam, open plastic bag and take out the unit.

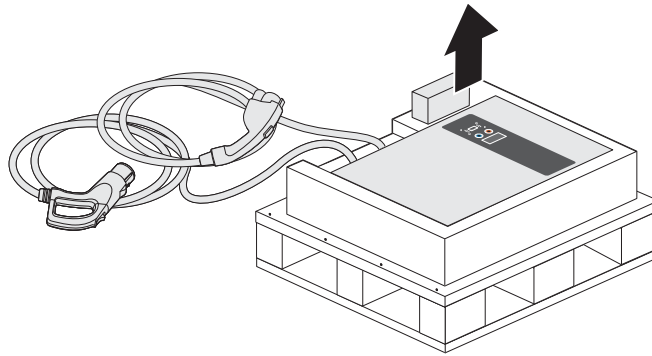

Note:
Carefully place the unit and the charging plug on the ground or a flat surface at this stage.

Wall Mounting

1. Use template and leveler tool to mark out the mounting position.

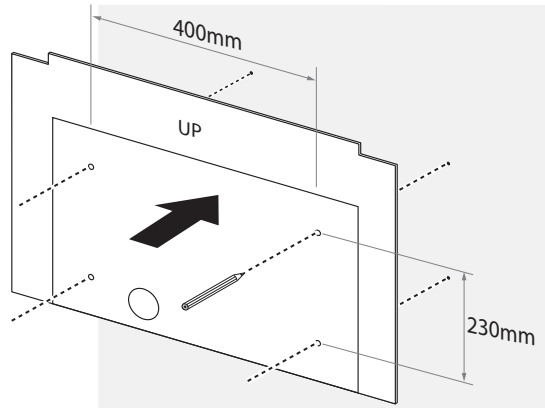

2. Mount bracket onto the wall.

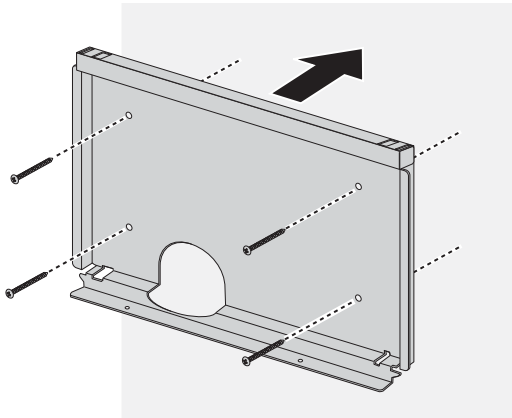

Note:

- **The unit must be mounted on a solid wall (concrete or metal preferred).**
- Use the expansion bolts in the accessory kit or choose proper mounting screws for different types of wall. A drilling machine might be needed for certain conditions.
- Follow applicable accessibility requirements for the mounting position. The unit must be mounted at a sufficient height from grade such that the height of the storage is located **between 60 cm (24 inches) and 120 cm (4 feet)** from grade per NEC Article 625.

3. Place unit onto bracket. Align the back chassis of unit with the corresponding slot on the bracket. Slowly slide down the unit until it sits firmly on the bracket. Fasten two screws from the bottom.

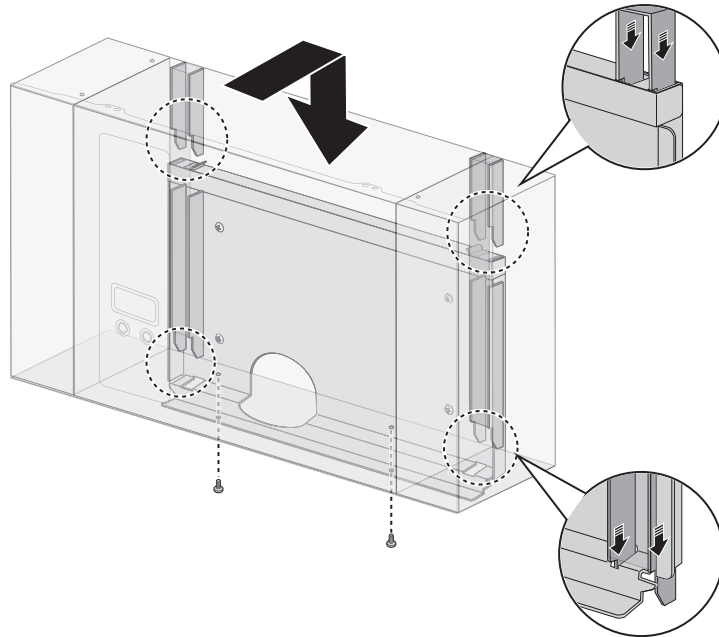

Note:
The bottom fixing screws are in the accessory kit.

Making the Connection



WARNING!

Only use a **Torx® Tamper-Resistant T15** screwdriver to secure or remove the screws. Use of any other tool may damage screws and panel.

Power Wiring

1. Open front cover for wiring.
 - a. Release two screws on top.
 - b. Release the latches to open front cover.
 - c. Put down front cover gently.

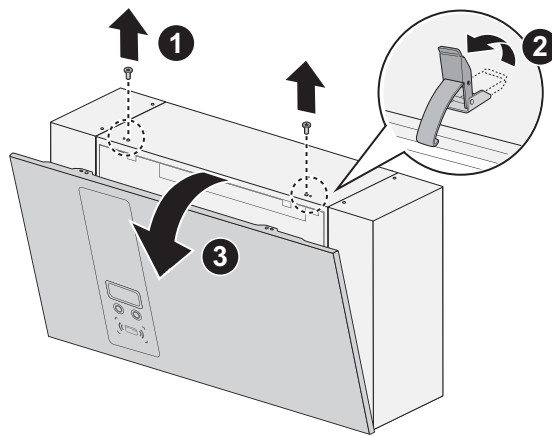

2. Routing the power wires is possible through the bottom or rear of the enclosure.
Select the location to route the power wiring.

Bottom-fed wiring:

- a. Feed the wires from the underside. Make sure the wiring can sufficiently reach the connectors before securing.
- b. Continue with the fastening of the wires, see the following step.

Rear-fed wiring:

- a. Remove the waterproof cap from the back of the enclosure and insert the waterproof cap in cable access location on the bottom of the enclosure.

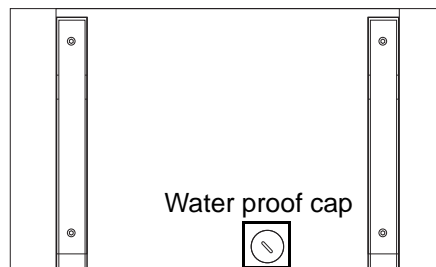

- b. Proceed with the following steps.



CAUTION!

BACK-FED WIRING MAY CAUSE THE RISK OF WATER LEAKAGE. DO NOT CHOOSE THIS WIRING CONNECTION IN OUTDOOR LOCATIONS.

3. Fasten cable gland to secure wires.

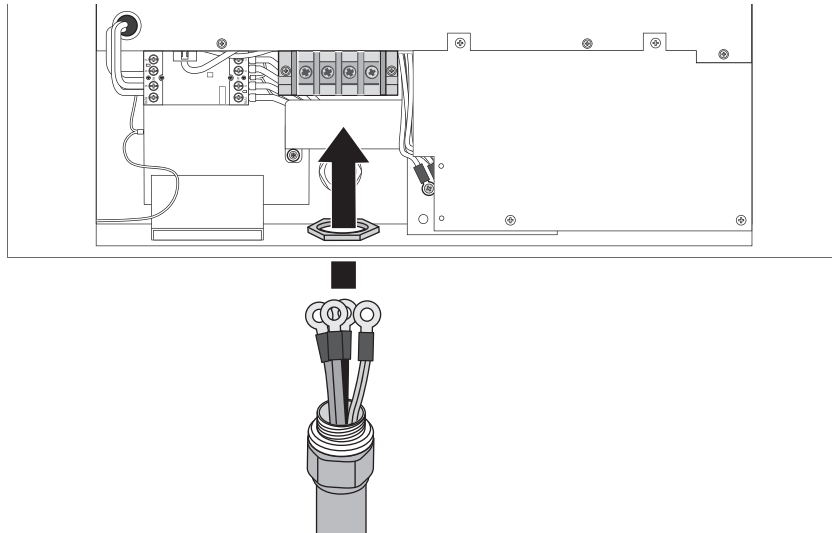

Note:

To insure protection from the elements, make sure to use **certified IP55 (or above)** cable glands.

4. Remove lid of terminal block and connect the wiring to the correct terminals. See the following information for specific model connections.

Wiring requirements are dependent on the model type and between single and three-phase models.



WARNING!

Cable color coding may be defined differently depending on the region.

Three-phase

Wiring the 380Vac - 415Vac

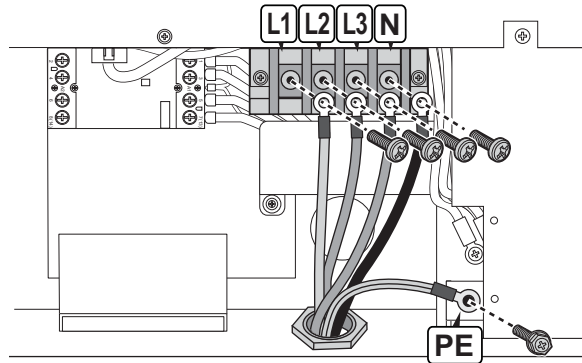

- Use conduit hub and conduit size M50 according to EN 61386-24.
- Connect the power wires of 4 x RNB14-6 ring terminal with cable lugs to the input terminal marked with "L1", "L2", "L3" and "N" using 4 x M6.0 screws with 33 kg-cm Torque force.
- Connect the ground wire of RNB14-6 into the earth terminal marked with ground symbol (⊕) using 1 x M6.0 screw with 20 kg-cm Torque force.

Wiring the 200Vac - 230Vac

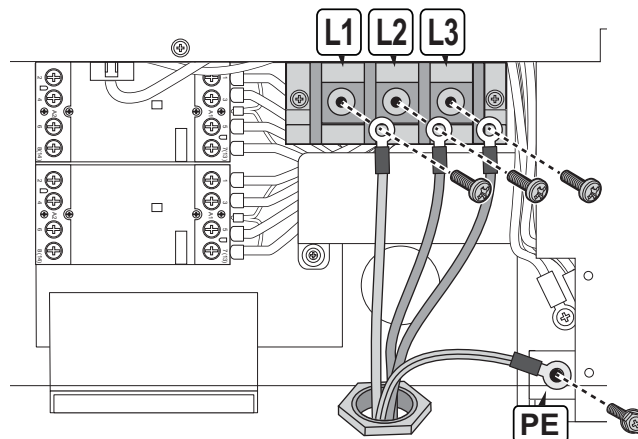

- Use conduit hub and conduit size M50 according to EN 61386-24.
- Connect the power wires of 3 x RNB38-6 ring terminal with cable lugs to the input terminal marked with "L1", "L2" and "L3" using 3 x M6.0 screws with of 33 kg-cm Torque force.
- Connect the ground wire of RNB14-6 into the earth terminal marked with ground symbol (⊕) using 1 x M6.0 screw with 20 kg-cm Torque force.

5. Fasten each wire with the proper screw. Make sure the correct amount of torque is used. See listed information.
6. Place lid back onto terminal block.

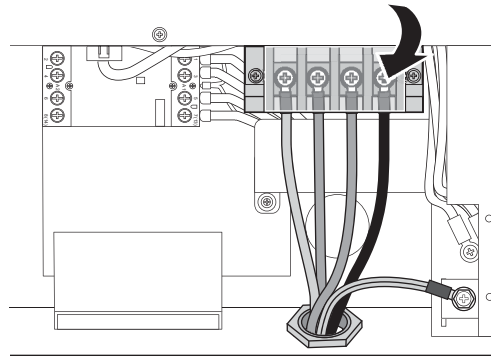

CAUTION!

MAKE SURE THE ELECTRIC WIRE CONDUIT IS ALIGNED WITH THE DC WALLBOX CHARGER INPUT WIRE OPENING PRIOR TO INSTALLATION. FAILURE TO DO SO COULD DAMAGE THE WIRING OR THE CHARGER.

7. Put front cover back and fasten screws securely.

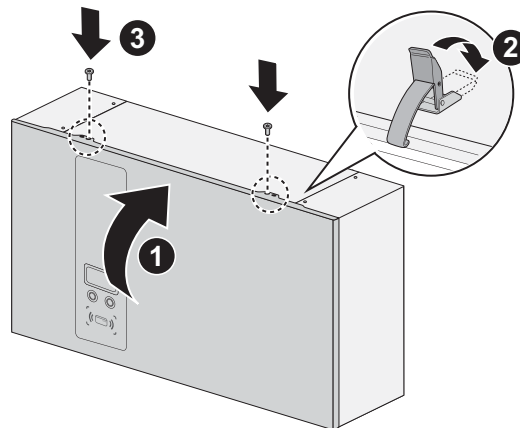

Ethernet Connection

It is recommended to connect Ethernet cables through the underside access ports. It is necessary to open front cover.

1. Remove the water proof cap from the Ethernet access port.

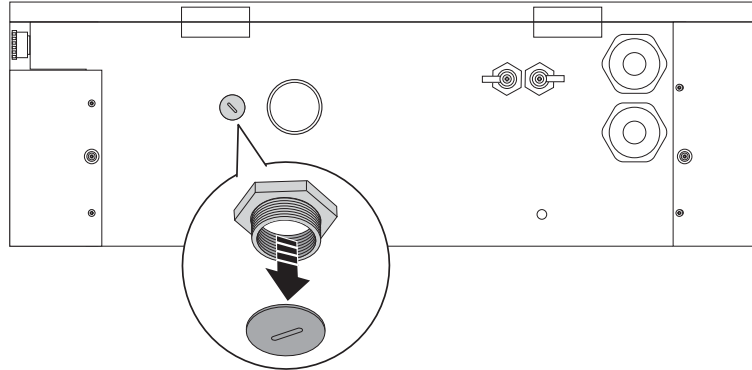

2. Insert the cable through the port and connect the Ethernet cable to the terminal.
3. Fasten the conduit or cable gland to secure the cable.

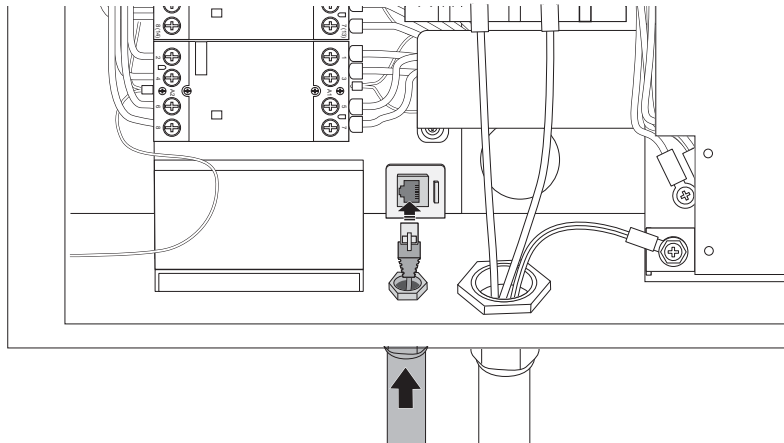

Note:

To insure protection from the elements, make sure to use **certified IP55 (or above)** cable glands.

3G Connection

1. Remove right filter cover.
 - a. Release the screws on the top.
 - b. Release the screws on the bottom and pull out the latch.
 - c. Open and remove the filter cover.

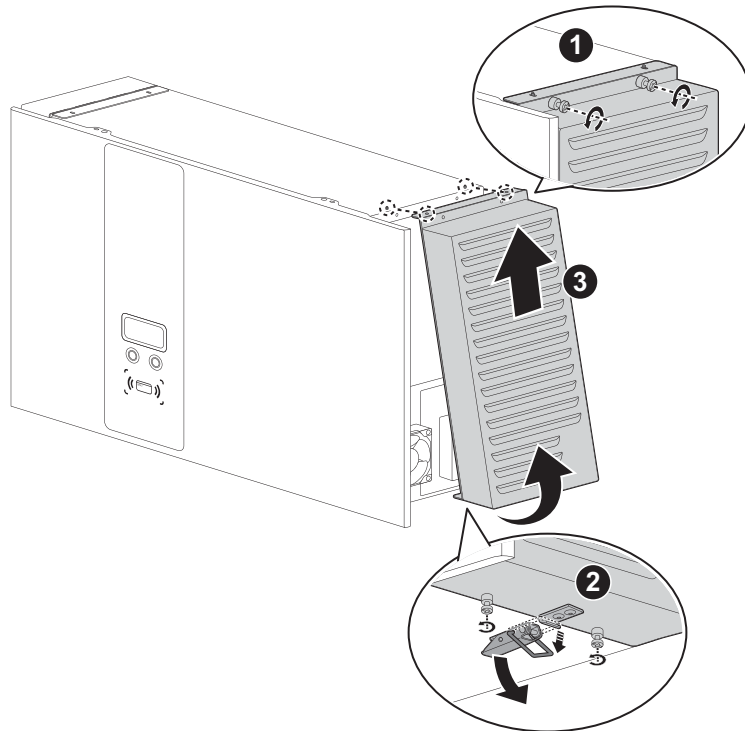

WARNING!

Only use a **Torx® Tamper-Resistant T20** screwdriver to secure or remove the screws of unit. Use of any other tool may damage screws and panel.

2. Remove the protection cover on the right side.

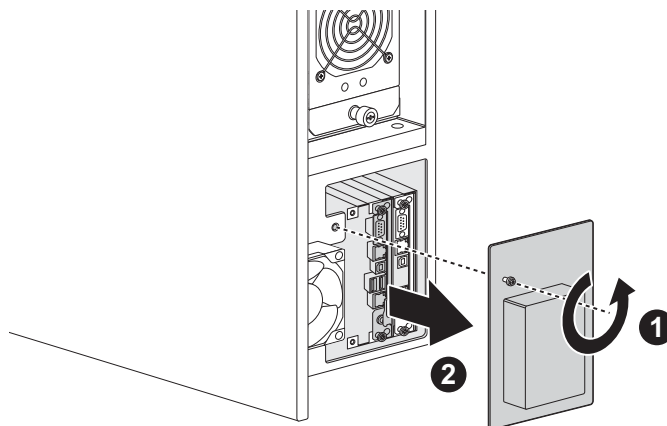

3. Insert micro SIM card onto 3G board. Fasten the protection cover back.

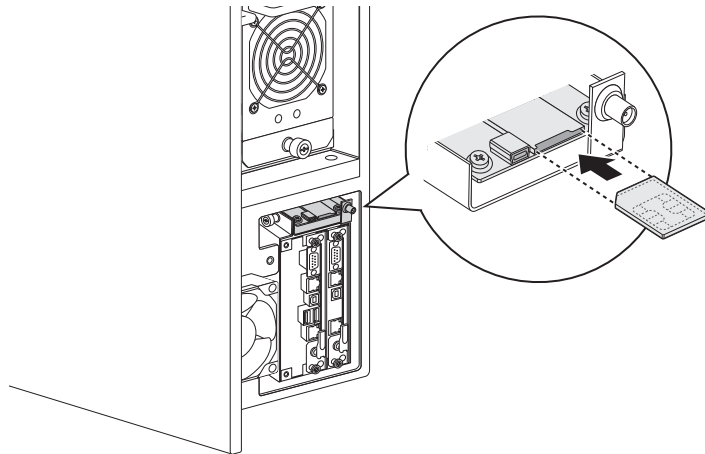

4. Return right filter cover.
 - a. Hang filter cover onto the unit.
 - b. Pull down the pin and place back filter cover.
 - c. Fasten screws on bottom.
 - d. Fasten screws on top.

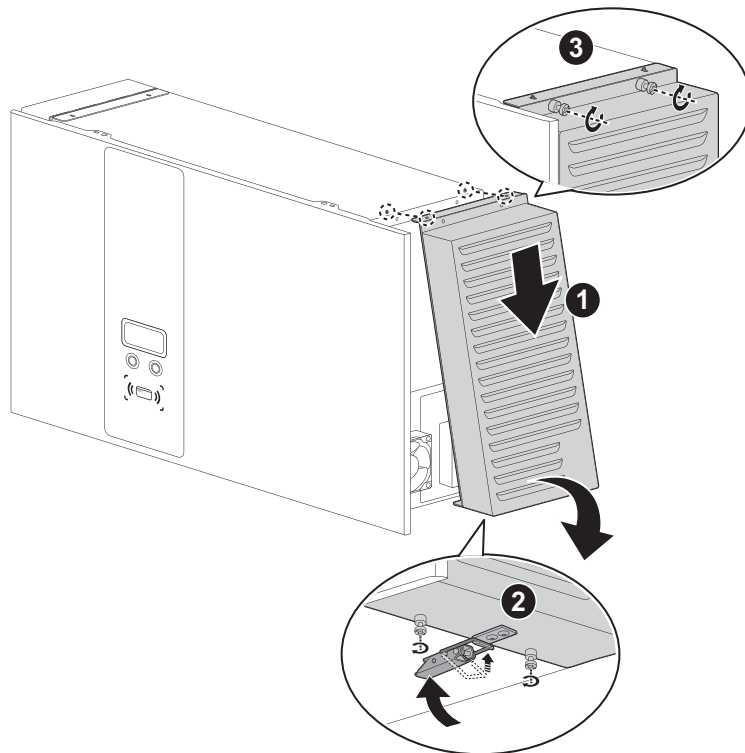

Set Charging Plug

1. Mount charging plug hanger onto the wall.
2. Place charging cable and plug on the hanger properly.

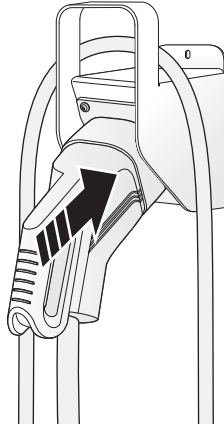

IEC DC (CCS2)

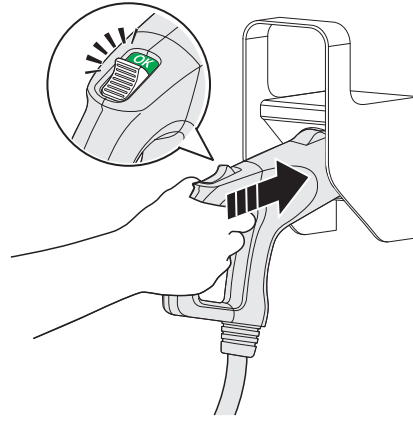

CHAdeMO - only for dual output model

3. Switch power on and turn the key to initialize DC Wallbox when all steps are completed.

Operation

1. Choose the preferred language.
2. Choose a compatible plug (CCS or CHAdeMO).

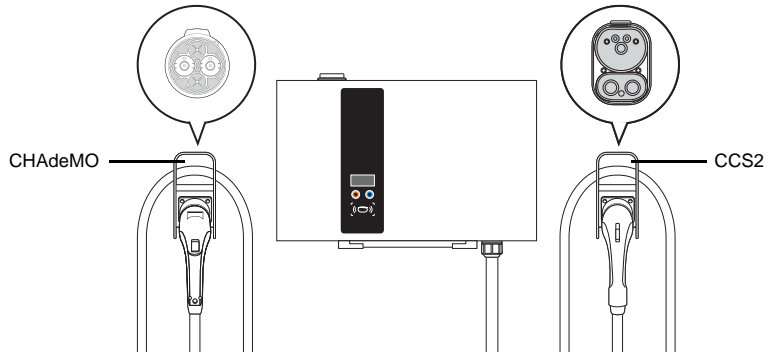

3. Connect the plug to the EV.

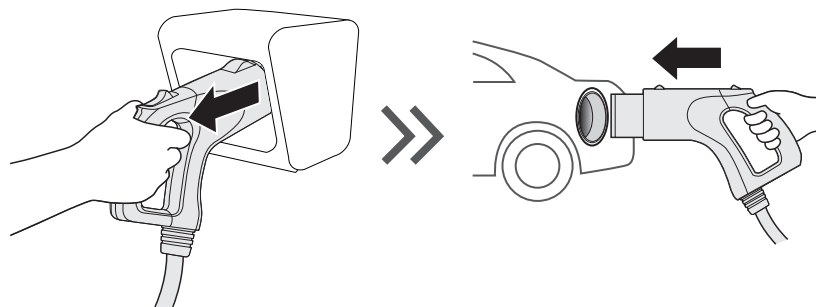

4. Swipe the authorized RFID card to start charging.

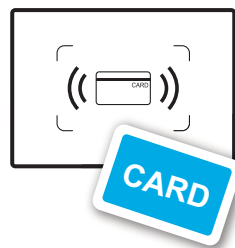

- Once charging commences, status information is displayed on the screen. The following illustrations demonstrate the start to near complete charging procedure.

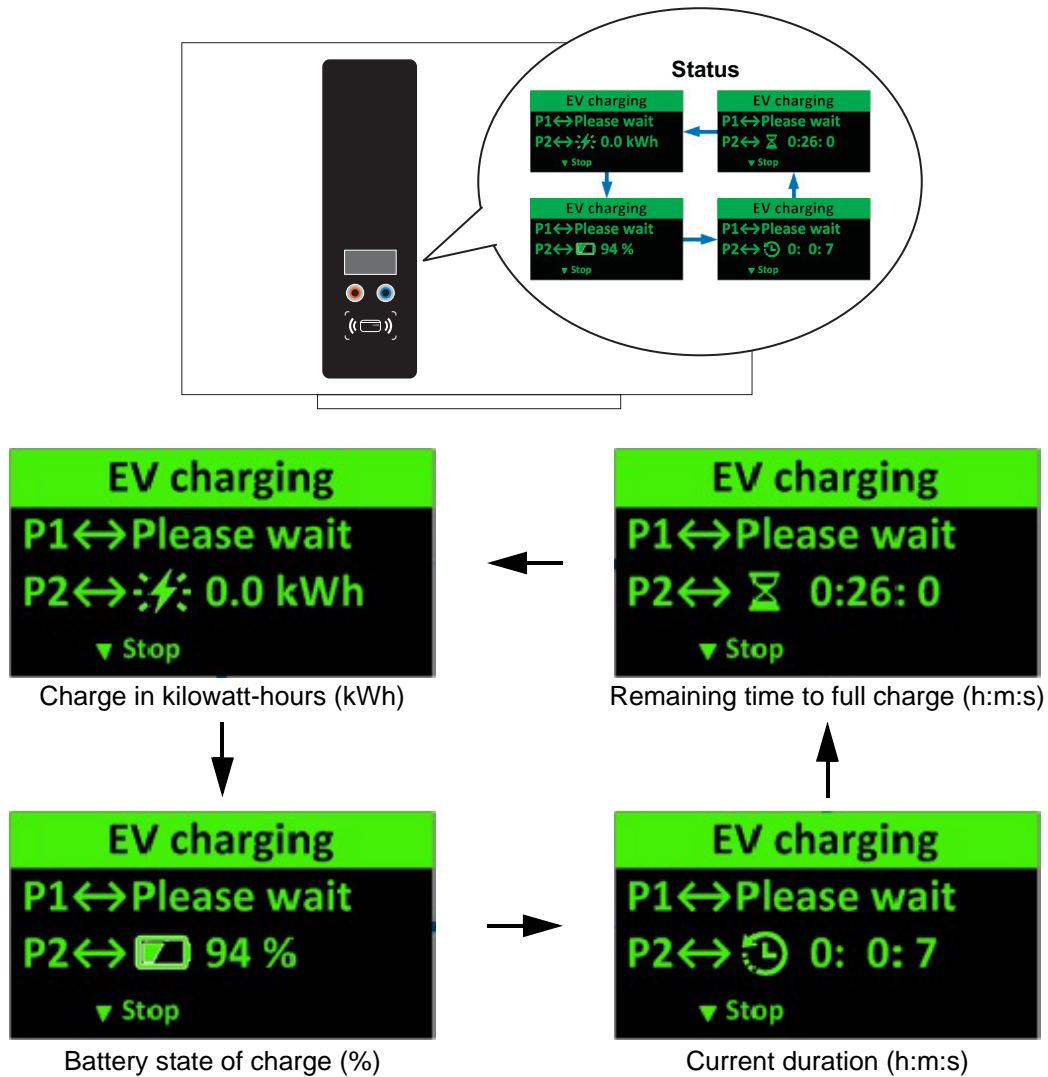

- Swipe the authorized RFID card to stop.

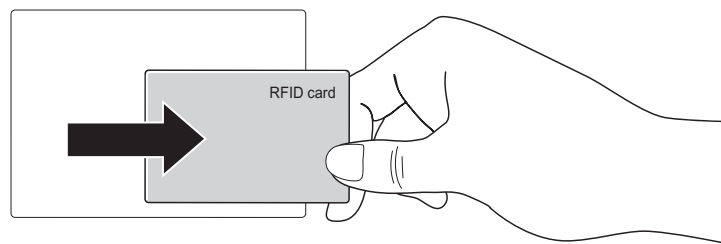

- Return the plug to the holder.

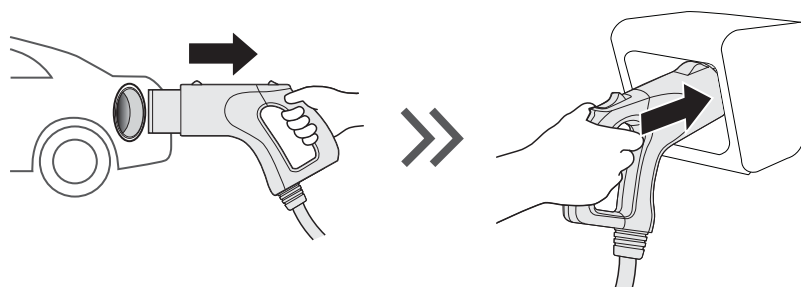

System Configuration



WARNING!

Only configure the charger when the charger is not in charging mode to avoid interruption of an ongoing charging session.

Steps:

1. Use the Windows-based configuration tool released by the DC Wallbox manufacturer.
2. Launch the configuration tool.
3. When the configuration is done, copy the parameter file (DeltaDCWallboxConfig) to the root of a USB flash drive (the file format should be FAT/FAT32).
4. Insert the USB flash disk into the USB port on the bottom (labeled USB). The configuration will be uploaded to the DC Wallbox.

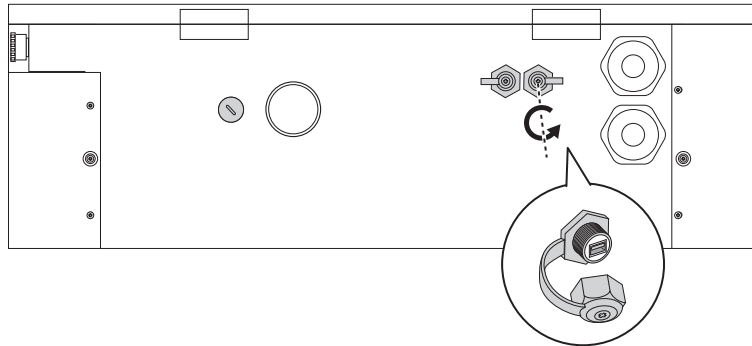

5. Remove the USB flash drive when the configuration is complete.

USB inserted
Configuration...



USB inserted
Configuration OK

3G Configuration

For models equipped with the 3G modem, insert a valid 3G (WCDMA) SIM card as detailed in previous steps (page 17) to start 3G connection. Consult with local operator to activate data service on the SIM card beforehand. Disable PIN check on the SIM card before inserting the card into the modem. Request APN information from the operator and make sure APN is configured correctly via the configuration tool.

Firmware Update

Firmware updates can be made via the USB port on the bottom of the cabinet.

1. Obtain a USB flash drive. The drive must be formatted to FAT/FAT32 format.
2. Insert the USB flash disk into the USB port on the bottom of the unit (labeled USB).

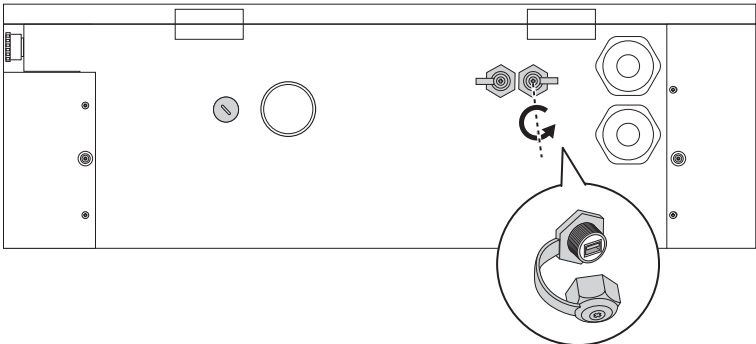

The updated firmware is uploaded to the DC Wallbox.

The status is displayed on the panel.

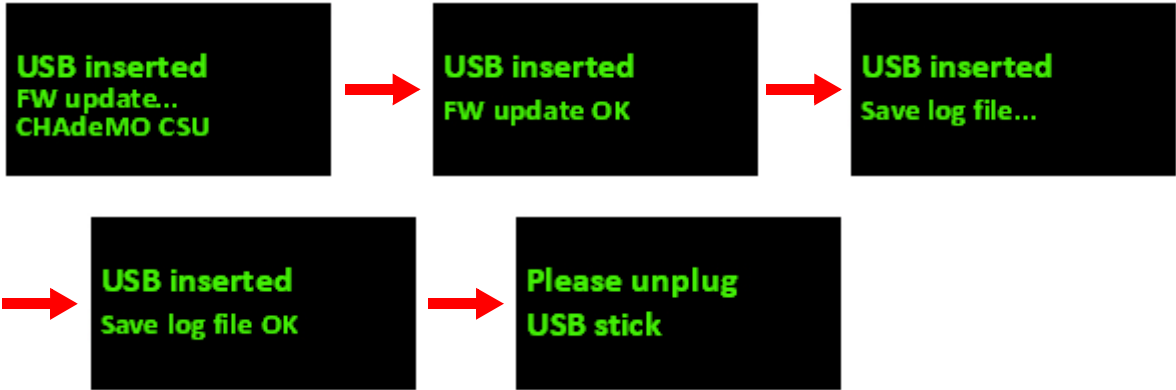

3. When system finishes the update procedure, it restarts automatically.

Maintenance

Every six months,

1. Replace the ventilation filter.
2. Conduct a visual inspection of the charging cable and ensure that cable does not show any visual damage or deformation.
3. Conduct a visual inspection of the charging gun and ensure that gun does not show any visual damage, arcing or rust.



WARNING!

To avoid danger of electrical shock or injury, turn off power at the panel board or load center before working on the equipment or removing any component. Do not remove circuit protective devices or any other component until the power is turned off.

Disconnect electrical power to the DC Wallbox before any maintenance work to ensure that it is separated from the supply of AC mains. Failure to do so may cause physical injury or damage to the electrical system and charging unit.



Note:

- Before switching off the main breaker to cut off power, please record the error code on the display screen.
- Even when the key switch is turned off, the circuit before the main terminal is still hazardous. Please only operate visual inspection at this moment.
- Maintenance of the DC Wallbox shall be conducted only by a qualified technician.
- After opening the front door, turn off the main breaker and auxiliary breaker before any maintenance work.

System Code

Alarm Code	Description
004001	System input voltage is higher than workable range (> 305 volt)
004002	System input voltage (L2 or L3) is lower than workable range (< 170 volt)
004003	System output voltage is higher than EV battery maximum voltage
004004	Request output current from EV is higher than present EVSE ability
004005	The temperature of air inlet or input contactor is higher than workable range (> 60°C)
004006	The temperature of CCS combo charging plug is higher than workable range <ul style="list-style-type: none"> ● REMA => (> 85°C) ● Phoenix => (> 75°C)
004007	The air filter need to be replaced
004008	System fan is attenuated so that need to be replaced
004009	The self test of system controller is failure
00400A	Emergency button is pressed
00400B	The user authorized by backend is failed
00400C	The user authorized by EVSE itself is failed
00400D	The temperature sensor of air inlet is broken
00400E	The temperature sensor of input contactor is broken
00400F	SPD trigger
004010	Output fuse at CCS side is broken
004011	Output fuse at CHAdeMO side is broken
004012	The temperature sensor of CCS combo charging plug is broken
004013	the temperature of air inlet or input contactor is lower than workable range (< -40°C)
004014	User stops charging
004017	System is timeout if user doesn't plug-in in 3 minutes after authorized
004018	Charging time is up (Max: 2hr)
004019	System data storage is not enough
004020	Unknow error
004021	Charging is remotely stopped by backend office
004022	Input voltage is drop (<20V, <100ms)
004023	System L1 input voltage is lower than workable range (< 170 volt)
005001	Communication with CHAdeMO EV is broken
005005	Communication with CCS EV is broken
005006	Power rectifier is broken (SMR)
005007	Communication with CCS controller is broken
005008	Communication with aux. power module is broken
005009	Communication with relay control module is broken
00500C	Communication with display module is broken

Alarm Code	Description
00500D	Communication with RFID module is broken
00500E	3G module is not ready (module itself or SIM)
00500F	WiFi module is not ready
006001	3G connection is disconnected from APN
006002	3G connection is disconnected from internet
006003	3G connection is disconnected from backend office
006004	WiFi connection is disconnected from AP
006005	WiFi connection is disconnected from internet
006006	WiFi connection is disconnected from backend office
006008	Ethernet connection is disconnected from internet
006009	Ethernet connection is disconnected from backend office
007001	Hardware component in power rectifier is broken
007002	Input voltage of power rectifier is higher than workable range
007003	Input voltage of power rectifier is lower than workable range
007004	Output voltage is higher than workable range of power rectifier
007006	The temperature of air inlet in power rectifier is higher than workable range (> 60°C)
007008	The temperature of PFC is higher than workable range
007009	The temperature of PFC is lower than workable range
00700A	The temperature of DCDC is higher than workable range
00700B	The temperature of DCDC is lower than workable range
00700C	The fan inside power rectifier is broken
00700D	Output oring diod is broken
00700E	Isolation test is failed
008003	5 volt for system controller is higher than workable range
008004	5 volt for other system modules is higher than workable range
008005	5 volt for CAN bus is higher than workable range
008006	12 volt for other system modules is higher than workable range
008007	12 volt for EV communication is higher than workable range
008008	24 volt for relay control is higher than workable range
008009	5 volt for system controller is lower than workable range
00800A	5 volt for other system modules is lower than workable range
00800B	5 volt for CAN bus is lower than workable range
00800C	12 volt for other system modules is lower than workable range
00800D	12 volt for EV communication is lower than workable range
00800E	24 volt for relay control is lower than workable range
008010	The output current of 5 volt for system controller is higher than workable range
008011	The output current of 5 volt for other system modules is higher than workable range

Alarm Code	Description
008012	The output current of 5 volt for CAN bus is higher than workable range
008013	The output current of 12 volt for other system modules is higher than workable range
008014	The output current of 12 volt for EV communication is higher than workable range
008015	The output current of 24 volt for relay control is higher than workable range
008016	The temperature of 12 volt for EV communication is higher than workable range
008017	The temperature of 5 volt for other system modules is higher than workable range
008018	The temperature of 24 volt for relay control is higher than workable range
008019	The ambinet temperature of aux. power is higher than workable range
009001	GFD trigger
009003	GFD pre-warnning
009004	GFD self-test fail
00A001	Input contactor 1 is welding
00A002	Input contactor 1 is drived fault
00A003	Input contactor 2 is welding
00A004	Input contactor 2 is drived fault
00A005	The positive side of output relay for CCS charging is welding
00A006	The positive side of output relay for CCS charging is drived fault
00A007	The positive side of output relay for CHAdeMO charging is welding
00A008	The positive side of output relay for CHAdeMO charging is drived fault
00A009	The negative side of output relay for CCS charging is welding
00A00A	The negative side of output relay for CCS charging is drived fault
00A00B	The negative side of output relay for CHAdeMO charging is welding
00A00C	The negative side of output relay for CHAdeMO charging is drived fault
00B001	The firmware update of aux. power module is failure
00B002	The firmware update of relay control module is failure
00B003	The firmware update of LCM module is failure
00B004	The firmware update of CCS charging module is failure
00B005	The firmware update of CHAdeMO charging module is failure
00B006	The firmware update of power converter module is failure
00C001	PLC module for CCS charging is broken
00C002	CCS proximity is disconnected
00C003	stop charging by CCS EV
00D001	No charging permission come from CHAdeMO EV
00D002	Battery malfunction come from CHAdeMO EV
00D003	Battery incompatibility with CHAdeMO EV
00D006	Present output current is different from target current
00D007	Battery OTP come from CHAdeMO EV

Alarm Code	Description
00D008	Present output voltage is different from target voltage
00D009	Position shift alarm is come from CHAdeMO EV
00D00A	EV other fault is come from CHAdeMO EV
00D00B	CHAdeMO connector lock is broken

Specifications

Model	EVDE25XXDXX	EVDE25XXEXX
Input rating	380~415 Vac; 50/60Hz; 50A max.	200~230 Vac; 50/60Hz; 90A max.
Wiring	3-phase/L1, L2, L3, N, PE	3-phase/L1, L2, L3, PE
Power factor	> 0.98	
Current THD	Compliant with EN61000-3-12	
Efficiency	94%	
DC output #1	1. IEC CCS DC Level 2, 50-500 Vdc, 60A max., 25kW max. or 2. SAE J1772 DC Level 2, 50-500 Vdc, 65A max., 25kW max.	
DC output #2	CHAdEMO, 50-500 Vdc, 60A max., 25 kW max.	
Protection	Over current, Under voltage, Over voltage, Surge protection, short circuit, over temperature, ground fault	
Display	2.7" OLED screen	
Push buttons	Multi-functional buttons (LED light: Orange, Blue)/Emergency stop button (Red)	
Authentication	ISO/IEC 14443 Type A/B RFID for user authentication	
Network interface	Ethernet (standard); 3G (optional, Micro SIM card); WiFi (optional)	
Operating temperature	-22°F to 122°F (-30°C to 50°C)	
Humidity	< 95% relative humidity, non-condensing	
Altitude	Up to 2000m (6500 ft.)	
Ingress rating	IP55	
IK rating	IK08 according to IEC62262	
Cooling	Forced air	
Charging cable	3.0m to 7.5m (9 to 25 ft.) straight cable	
Dimension (W x H x D)	680 x 430 x 230 mm (27 x 17 x 9 inches)	
Weight	47kg (104 lbs), excluding plug and cable	
Certificate	IEC 61851-1, IEC 61851-23	