

Case	Application of Delta's AC Motor Drive in Fan and Pump System				
Issued by	Solution Center	Date:	Feb. 2009	Pages	2
Applicable to	Delta VFD-EL and VFD-F series AC motor drive				

The AC motor drive is more and more used in the water supply of daily life, building and industry. It can be used to adjust water pressure and set pressure for each application. In terms of constantly changing of water flow, such as daily life water, it can save energy by changing the speed of pump to adjust the flow. In addition to energy-saving, it also has the following advantages by using the AC motor drive for constant pressure water supply applications:

1. The start current of pump can be controlled in the rated current to prevent the inrush current at power up and keeps the stable power supply.
2. It can extend the use life of pumps and valves due to low average speed of pump.
3. It can prevent the water hammer effect at start and stop.
4. It can decrease the full-speed time of pump and noise when adjusting the speed by the AC motor drive.

Application of VFD-EL

The constant pressure pump is suitable to be used in the water supply with constant pressure, such as home, motel and SPA. Delta's VFD-EL series is the AC motor drive with the multiple functions and compact size and power ranging 0.2~3.7kW. With its built-in constant pressure water supply function, the applications of constant pressure water supply are more convenient and economic. See the following figure for the application structure:

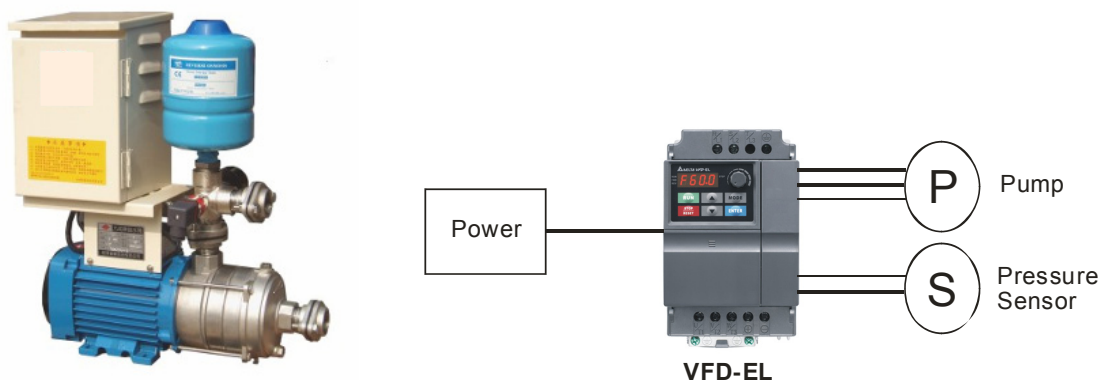

Application of VFD-F

The multiple-pump constant pressure/flow water supply is the common variable-frequency water supply application of large water supply plant or building automation. The most energy-saving method of multiple-pump building water supply system is to use PID control of the AC motor drive. Delta's VFD-F series is the AC motor drive exclusively designed for fan and pump systems with power range from 0.75 to 220kW and built-in multiple-pump constant pressure water supply function.

The multiple-pump control is to use an AC motor drive to control the water flow/pressure of multiple motors. When it needs small water flow, the AC motor drive will operate with a pump and change pump's speed by the change of water flow for the constant pressure water supply. When it needs large water flow and the AC motor drive is 60Hz, the AC motor drive will auto change this pump to the commercial power and run with the next pump. With the increment of water flow, each pump will be operated one by one. When the water flow is decreased, it will stop the pump that runs with the commercial power. Thus, it can adjust the water flow and save energy. See the following figure for the application structure.

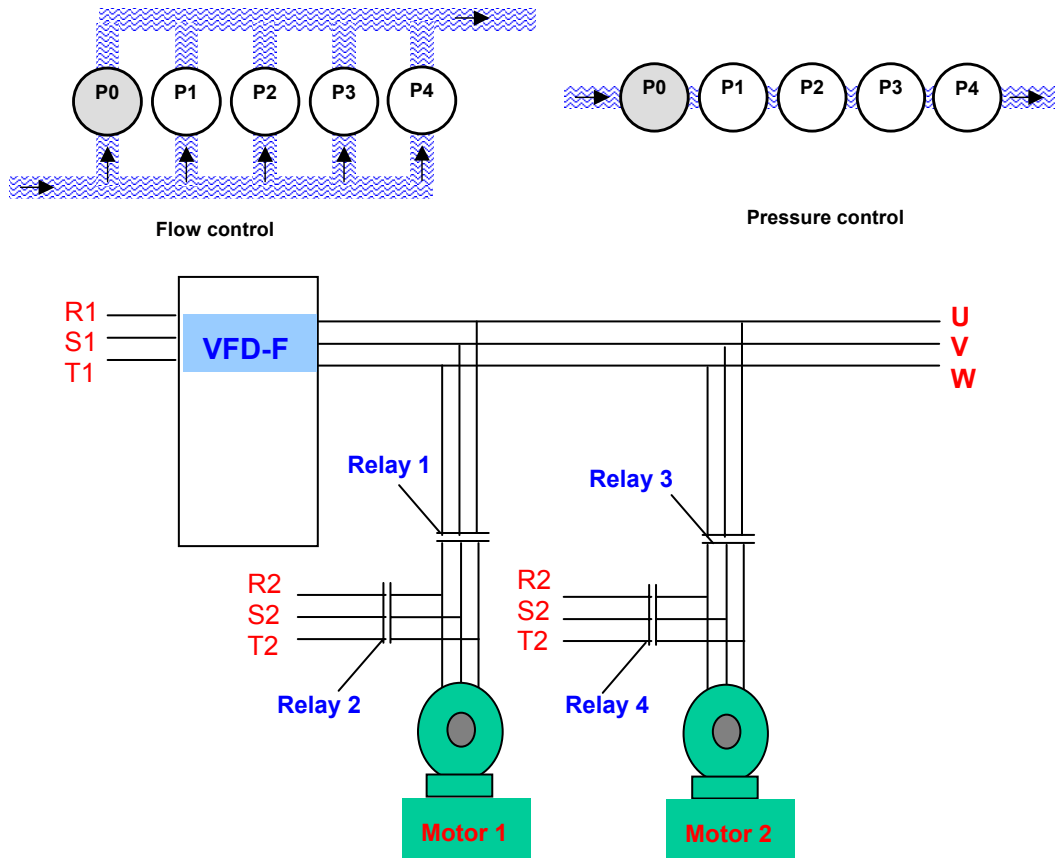

More information on Delta's VFD series AC motor drive, visit our website at http://www.delta.com.tw/product/em/drive/ac_motor/ac_motor_main.asp