



PM1350 Power Module

MOOV^{base}

High efficiency modular charging for industrial applications

Designed for installation in charging cabinets where each module delivers up to 1350 W. The module is controlled by a system controller via CAN bus and is capable of charging a wide range of battery types.



Battery
Charging



Industrial



Features

Safe and Robust

- Advanced safety design and error detections safeguard the user, battery and charger
- Galvanized steel enclosure and user-serviceable fan for use in tough industrial environments

Scalable Modular Design

- Connect in parallel to achieve desired charge current level
- Redundant operation
- Individual modules can be turned off allowing greater system efficiency

Simple Integration

- CAN bus allows easy control via a system controller
- System error and warning information communicated
- Backplane connection enables fast installation

Global Compatibility

- Wide ranging AC input allows worldwide grid connection
- Safety and EMC approvals for North America, Europe and Australia
- Efficiency exceeds CEC requirements

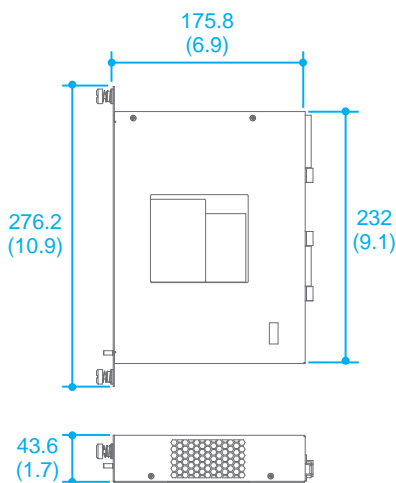

Dimensions in mm (inches)

Specifications

Part Number	PM1350	
AC Input		
AC Input Rated Voltage	100 to 240 V _{AC} 1PH	
AC Input Voltage Range	85 to 265 V _{AC}	
AC Input Frequency	50 / 60 Hz (47 to 63 Hz)	
Maximum AC Input Current	13.5 A	
Power Factor	0.98 to 0.999	
Efficiency	≥ 91%	
DC Output		
	24 V model	36 V / 48 V model
DC Output Voltage Range	9 to 35 V _{DC}	12 to 70 V _{DC}
DC Output Voltage Accuracy	± 0.5%	
Maximum Charge Current for AC Input Voltage < 160 V _{AC} / ≥ 180 V _{AC}	40 A / 45 A	27 A / 27 A
Load Current Accuracy	± 2%	
Maximum Output Power for AC Input Voltage < 160 V _{AC} / ≥ 180 V _{AC}	1,200 W / 1,350 W	
Environmental Conditions		
Operating Temperature	-10 °C to +70 °C (+14 °F to 158 °F) ¹⁾	
Storage Temperature	-40 °C to +85 °C (-40 °F to +185 °F)	
Relative Humidity	15% to 95%, non-condensing	
Maximum Operating Altitude	2,000 m (6,651 ft)	
Mechanical Design		
Dimensions (L x W x H)	232 x 175.8 x 43.6 mm (9.1 x 6.9 x 1.7 in) 276.2 mm (10.9 in) including front panel	
Weight	2.0 kg (4.4 lb)	
Cooling	Forced air. Internal DC fan with fan speed control	
AC Input Connector	FCI PwrBlade 3P backplane connector	
DC Output Connector	FCI PwrBlade 2P + 12S pin backplane connector	
DC Output Protection		
Over Voltage Protection	Yes	
Over Current Protection	Yes	
Short Circuit Protection	Yes	
Over Temperature Protection	Yes	
Reverse Protection	Yes	
Output Fuse	Yes	
Approvals		
Safety	UL1564 / CSA C22.2 107.2-01, IEC 60950-1, IEC 62368-1	
Safety Marks	cURus / CE / RCM	
Protection Class	1	
EMC Emissions	FCC Part 15 Subpart B, EN 61000-6-4 (EN 55011/32), Class B	
EMC Immunity	EN 61000-6-2	
Harmonic Currents	EN 61000-3-2	
RoHS	Yes	

Notes: An isolated supply is provided to power system components (12.0 V_{DC} ± 10%: 0 - 700 mA).

Modules in parallel multiply this output current.

An isolated CAN bus supply is provided to power system CAN bus components (7.5 V_{DC} ± 10%: 0 - 100 mA).

1) Output power may be derated above 45 °C (113 °F)

© Copyright – Delta Energy Systems (Germany) GmbH – All rights reserved. All information and specifications can be modified without prior notice.



More information

Delta Energy Systems (Germany) GmbH

Tscheulinstrasse 21, 79331 Teningen

E-mail: IEV.sales@deltaww.com

www.deltaww.com

2021 / 6 Version 2.1

