

Note	Packaging Wrapping Machine				
Issue by	SC	Date	NOV, 2013	Pages	16
Applicable to	ASD-A2 series AC servo motor and drive				

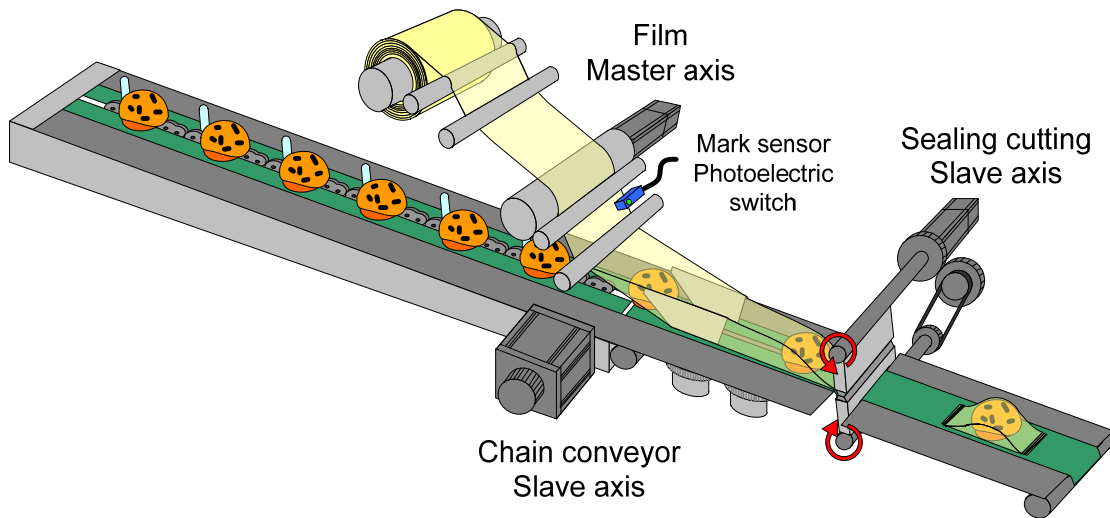

3.6 Application Example of Packaging Wrapping Machine

3.6.1	Description	3
3.6.2	System plan	3
3.6.2.1	Master axis (Film feeding axis).....	3
3.6.2.2	Camshaft (Flying shear).....	3
3.6.2.3	Camshaft (Chain conveyor)	4
3.6.3	Servo system setting.....	4
3.6.3.1	System configuration	4
3.6.3.2	Function introduction.....	5
3.6.3.3	The design of E-cam curve	12

3.6.1 Description

This chapter aims at the application of ASDA-A2 on packing machine, which is for using the compensation of flying shear and mark tacking. If the film has improper tension adjusting, mechanical slips or the distance between marks is different, ASDA-A2 has the automatic correction feature to correct the errors. Moreover, functions such as to avoid empty pack, to stop cutting when the package is in wrong position so as to avoid damaging the mechanism, function of initial position adjusting, to produce the adequate E-cam curve base on different width of cutter as well as the masking function between marks all provided by ASDA-A2. It offers a novel way for servo drive users in packing industry, including the servo system with motion command and brings a faster and more smoothing operation. Dramatically increase the performance and reduce the cost of design and development. Especially the function of mark tracking, it is definitely a great tool for the application of flying shear.

3.6.2 System plan

The packing system consists of three main parts, see diagram 3.6.1. The film feeding axis is the master axis. When it is delivering the film, it issues the pulse to command the slave axes. The first slave axis is the cutting axis for sealing and cutting while the second one is the chain conveyor which is used for delivering packages. The name of the first and second slave is only for explanation in this chapter and is not named in sequence in real application. It is the typical packing system. E-cam and motion control function of ASDA-A2 can satisfy the demand of each main control in this framework.

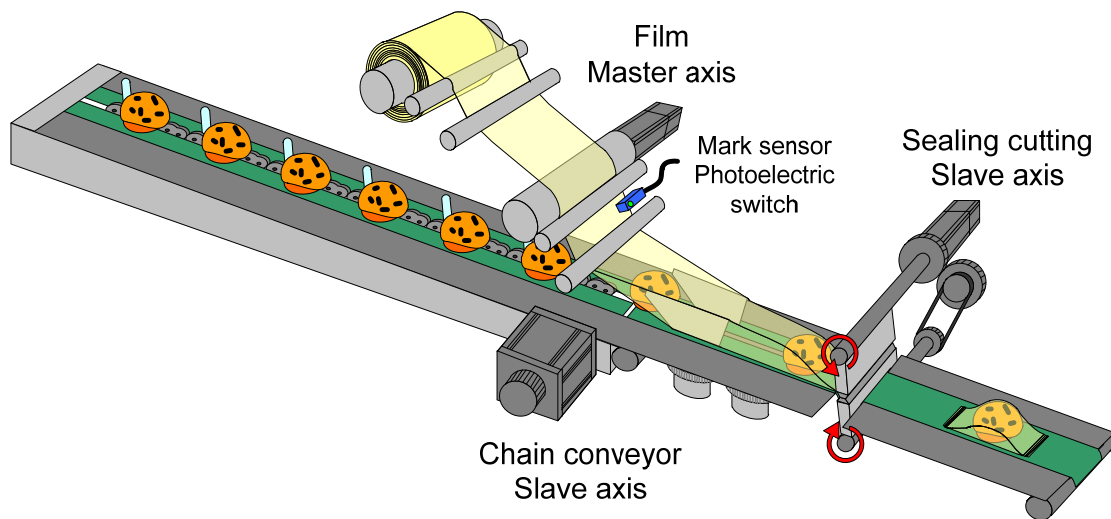

Diagram 3.6.1 Packing system

3.6.2.1 Master axis (Film feeding axis)

This axis is for delivering the film for packing. The delivery should be smooth, e.g. the mechanical tension should not be too big or it might extend the length of film. However, if the tension is loose, the film feeding bobbin would slip easily. The above two situations would cause the problem that the pulse number sent by master axis does not consist with the length of film. Although the error could be corrected by ASDA-A2, a smoothing film delivery is still a vital task for packing machine.

3.6.2.2 Camshaft (Flying shear)

The design of flying shear should consider the proportion of actual cutting length and flying shear spacing. The disproportion would cause the dramatic speed change while cutting and might become the bottleneck of improving the productivity. Take diagram 3.6.2 as the example, for the same length of cutting within the same time, the distance the single cutter travels is two times of two cutters (the distance between tools). If the required cutting distance is short, single cutter is easier to reach the limit (acceleration / deceleration limit and torque limit) than two cutters. This is because the single cutter needs to travel longer distance for a cycle. With the same speed, it needs a faster acceleration and deceleration. Thus, this issue should be taken into consideration when designing the mechanical structure. Using ASDA-A2 to control flying shear, camshaft would have the mark tracking function. Please see later parts for further details.

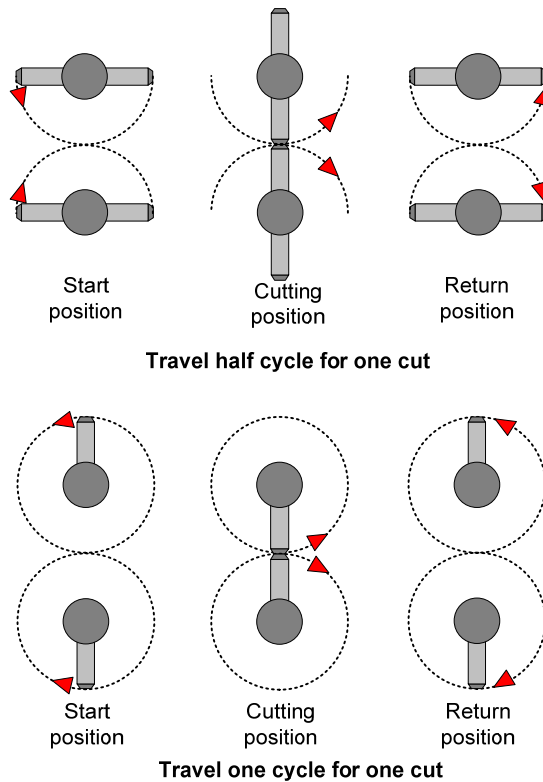

Diagram 3.6.2 The comparison of cutting travel distance

3.6.2.3 Camshaft (Chain conveyor)

Chain conveyor receives the pulse sent by master axis and synchronizes with master axis. With ASDA-A2, this axis has the function of pulse tracking and mark correction which will be elaborated later.

3.6.3 Servo system setting

3.6.3.1 System configuration

While the master axis delivers the film, it sends the pulse to camshaft simultaneously. Since ASDA-A2 has build-in function of pulse by-pass, when sending pulse to slave axes, the delay time of each axis is 50ns and the signal will not be attenuated. Repeater is included in ASDA-A2 servo drive, thus, it will not increase the cost when applying to multi-axis. Apart from pulse, mark signal also needs to be distributed to two slave axes so that the system can conduct the function of mark correction, see diagram 3.6.3.

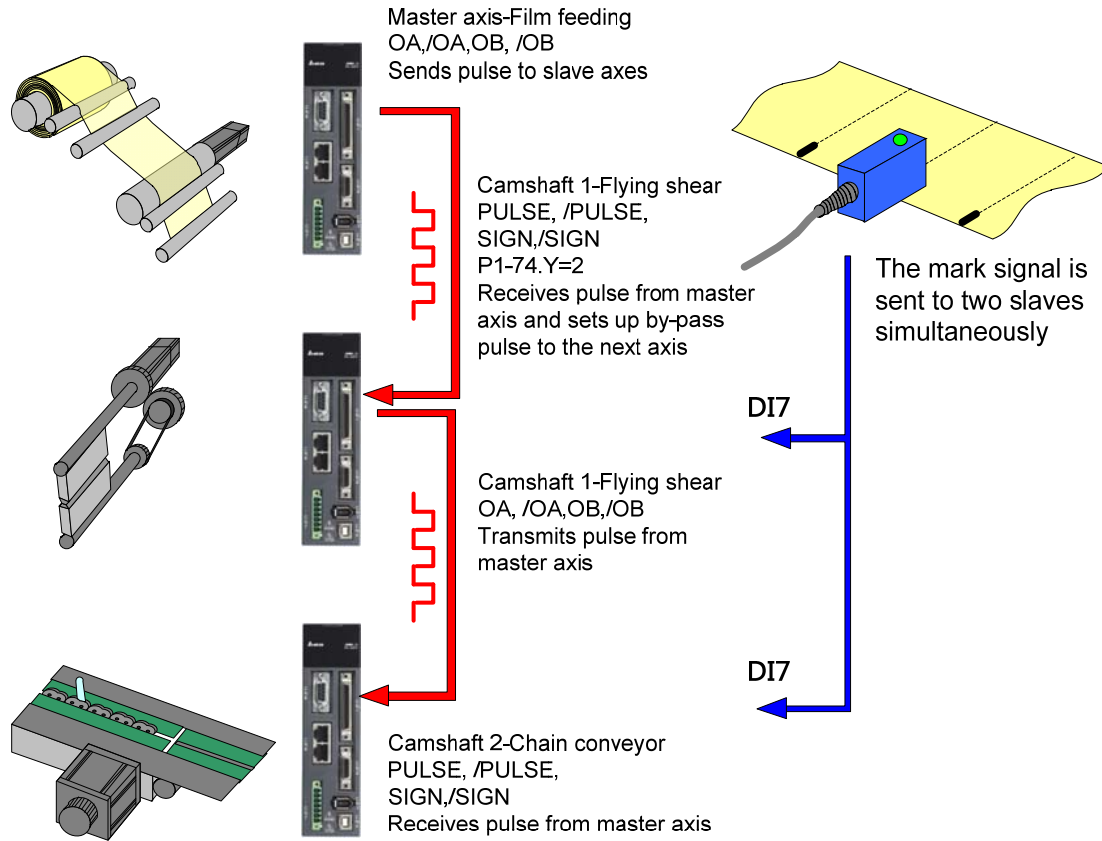

Diagram 3.6.3 System configuration

For different color of mark, e.g. black mark with white background or vice versa can be done by changing the setting of ASDA-A2. No need to change the photoelectric switch to read the mark, see diagram 3.6.4.

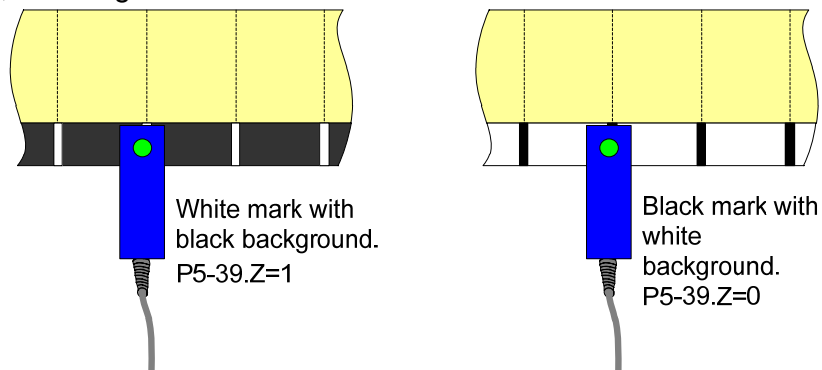

Diagram 3.6.4 The setting of different color mark

3.6.3.2 Function introduction

Adjusting the cutting position

A great development of ASDA-A2 on packing machine is the function of mark correction. The packaging film has ductility, thus it is very sensitive to different tension. When the tension is too big, it would extend the length of packaging film; if the tension is loose, the packaging film slips easily. These two situations would cause the default pulse number cannot consist with the cutting length and result in incorrect cutting. Synchronous capture axis of ASDA-A2 is design for improving this situation. When the film is deformed or slips, the cutter is unable to aim at the default cutting point, the system will be compensated by this function and the cutting position will be adjusted to the right position. See diagram 3.6.5.

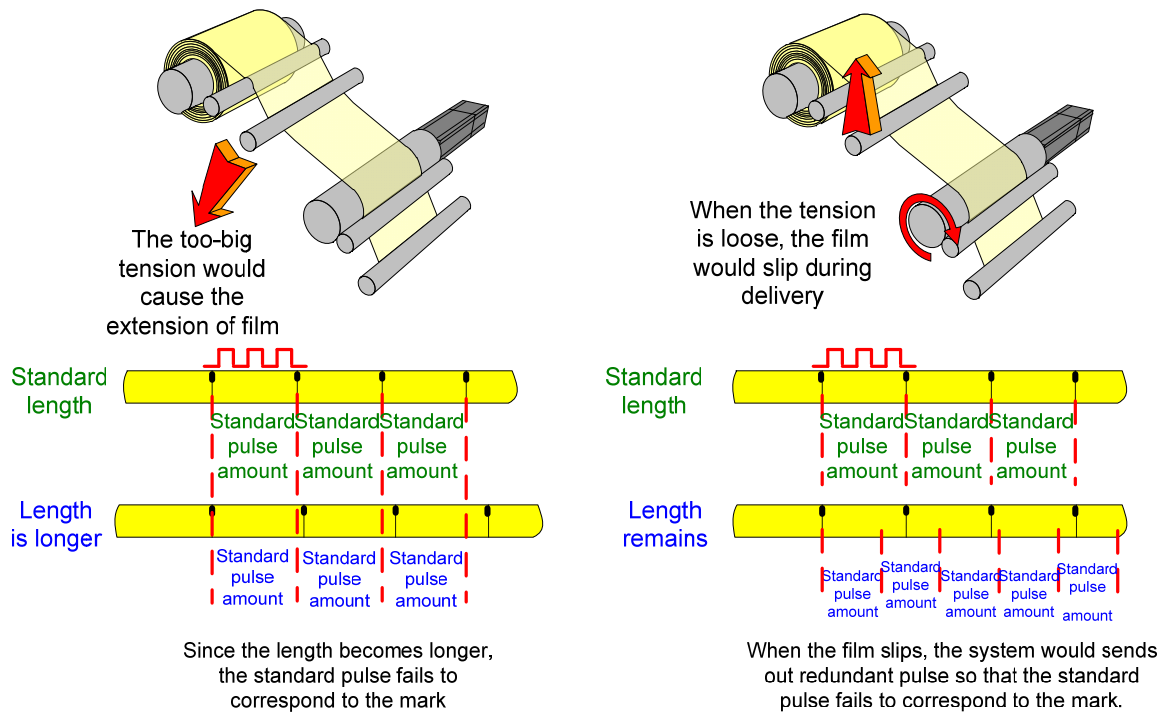

Diagram 3.6.5 The cause of incorrect cutting position

Build-in function of masking and cutting with missing marks

The system inspects the actual length by marks printed on packaging material. Thus, mark plays an important role to the system. To make sure the mark can be read by the system is a vital task. In order to avoid the spot interference between marks, ASDA-A2 is embedded with masking function which can setup the start position of reading the mark. Besides, when the mark is poor printing, the system is still able to trim according to the last cutting length and makes the correction when the mark appears again.

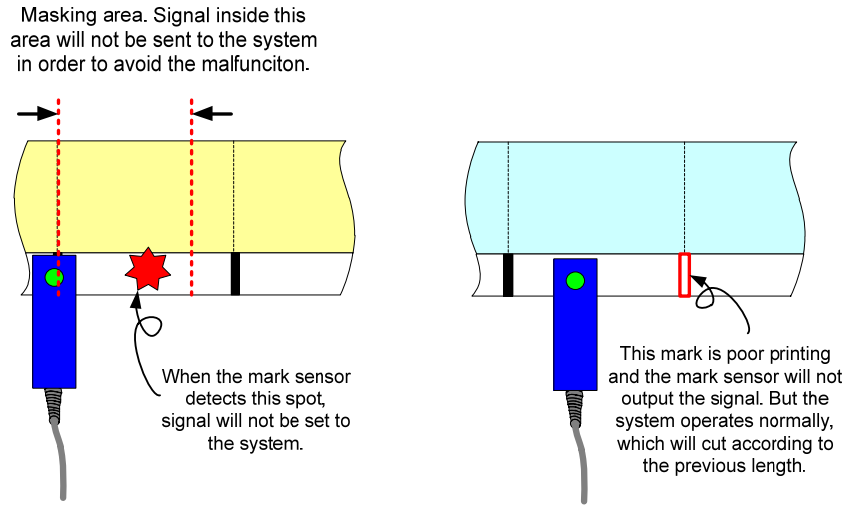

Diagram 3.6.6 Masking and cutting with missing marks

Function of initial position adjusting

When changing the packaging film, the system needs to adjust the position of cutter and mark. Synchronous capture axis function of ASDA-A2 can apply the synchronous error created manually to complete the function of position adjusting. Enter the pulse number into P5-79 and memorize the total correction amount in P5-87. After re-power on, the system will trim the packaging film according to the setup offset position before the previous power-off.

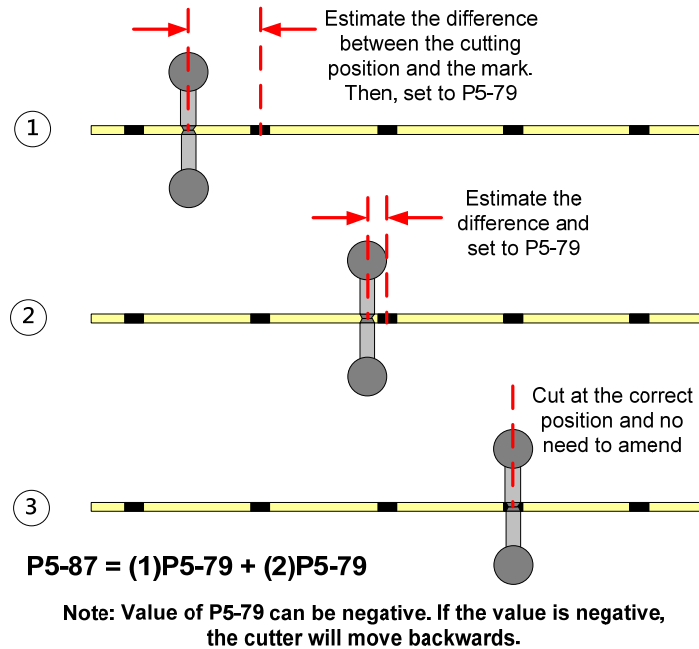

Diagram 3.6.7 Function of initial position adjusting

Empty pack skip function

ASDA-A2 uses the feature of motion command overlap. With the assistance of a PLC controller, it can skip the empty pack. The inertia produced by mechanism when stops instantaneously should be considered. Thus, when in high speed or heavy load, this function is not suitable for operation. See diagram 3.6.8. This function can deal with the problem of one empty pack or more than one empty pack. The prerequisite is to properly arrange the photoelectric switch of empty pack sensor 1 and 2. When the flying shear is at 0 degree or a proper position (the reference point for detection), empty pack sensor 1 might detect if there is any package on chain conveyor. If it is in situation 1, it means no empty pack. One empty pack is shown in situation 2. If there is more than one empty pack, then it is in situation 3. Thus, the condition of detecting empty pack should be:

No empty pack: (Signal of E-cam is at 0 degree) **AND** (Empty pack detection 1)
 One empty pack: (Signal E-cam is at 0 degree) **AND** (NOT Empty pack detection1)
 More than one empty pack: ((Situation 2) **OR** (Situation 3)) **AND** (Empty pack detection1)
AND (NOT Empty pack detection2)

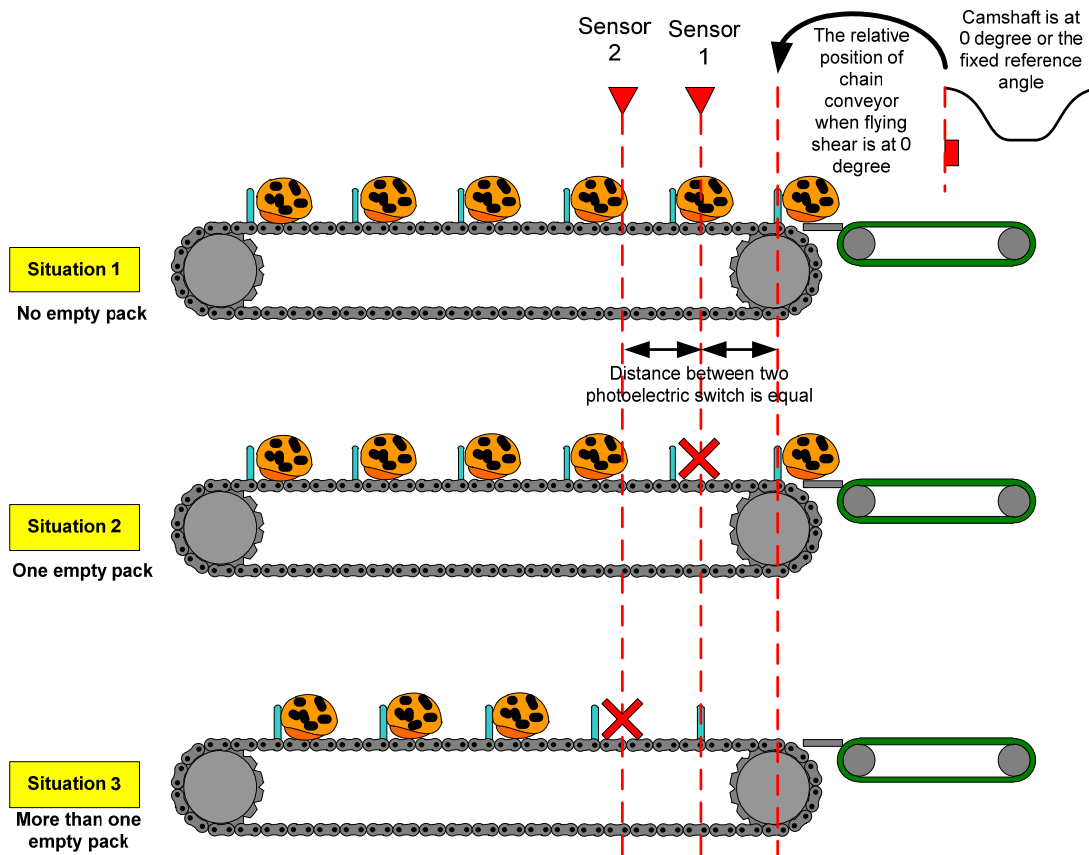

Diagram 3.6.8 Photoelectric switch for detecting empty pack

When empty pack is detected, the controller will trigger EV in a proper time and conduct offset compensation. Since ASDA-A2 has the feature of command overlap, skip empty pack can be done by this function. Base on the arrangement of sensors which shown in diagram 3.6.8, when the number of empty pack is more than one, the system could detect if the next pack exists or not before the previous command execution is completed. The continuous trigger event of the controller would cause command overlap. Meanwhile, when the number of empty pack is a lot, the controller could stop the master axis (film feeding axis) and keep all camshafts in engaging status after packing. After all empty pack is gone, operate the master axis again and the system will return to the original operation status. Diagram 3.6.9 shows the description of command overlap.

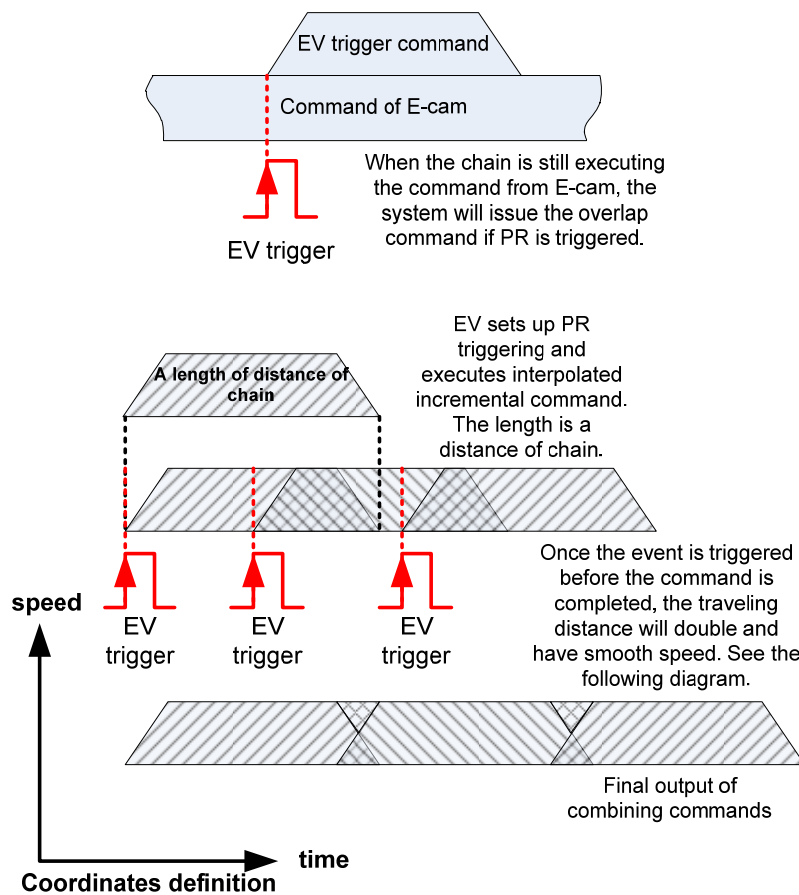

Diagram 3.6.9 The combination of empty pack command

Cutting skip with incorrect object position

Before cutting, if the package is in wrong position, in order to avoid the wrong cutting and damage the mechanism, proper defense mechanism is a must. See diagram 3.6.10.

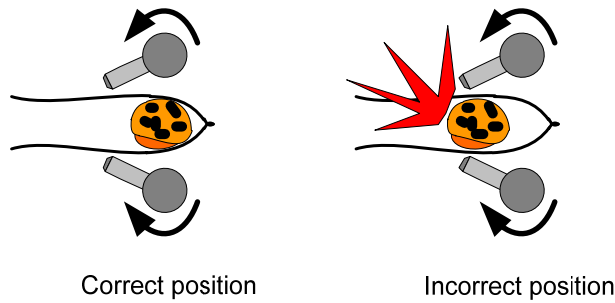

Diagram 3.6.10 Shift of package

Double-layer of protection is provided by ASDA-A2. If the wrong position of package is detected before entering the cutting area, the disengaged condition could be changed to periodically disengaging. (P5-88.U=C. If P5-88.U is set to 4 as the disengaged condition, when P5-92=0 and the camshaft is in high speed operation, it will cause non-continuous speed at 360 degrees of the curve. Set P5-88.U to C could avoid the situation and have the same function as P5-88.U=4, periodically disengage. Firmware version after V1.027 Sub.6 supports P5-88.U=C). It also can satisfy the demand of one or more cutting skips through adjusting lead pulse (P5-92). See diagram 3.6.11.

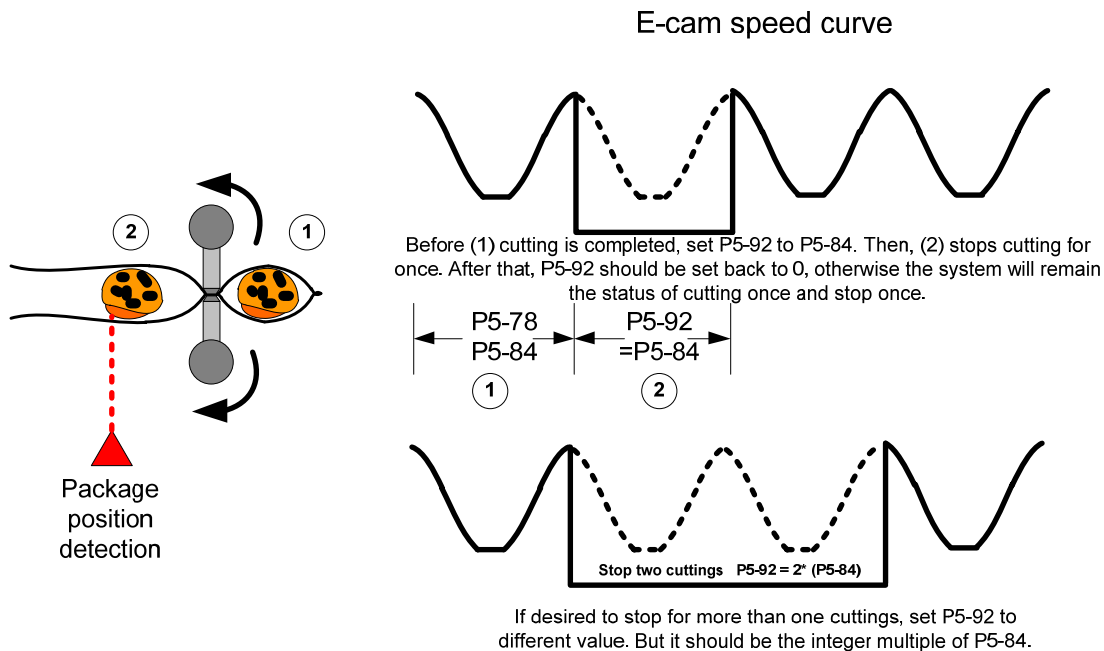

Diagram 3.6.11 Controls cutting by periodical lead pulse

If the system cannot detect the wrong position of the package before entering the cutting area, then users can apply torque limit function of the servo drive. It could limit the strength of cutter. When the cutter reaches the setting value of torque limit, the DO signal will be

issued to inform the controller to stop delivering the film. And the alarm will be cleared by the operator. The camshaft remains at engaging status at the moment and stops operation since the pulse stops issuing. After removing the package, the master axis will keep delivering the film and the system will continue the previous cycle. See diagram 3.6.12. Use torque limit as the mechanism protection when the package is in wrong position, the system program should be taken into consideration. If the system is in normal operation, and its torque value is close to the maximum value that servo drive can output, then this way is inappropriate.

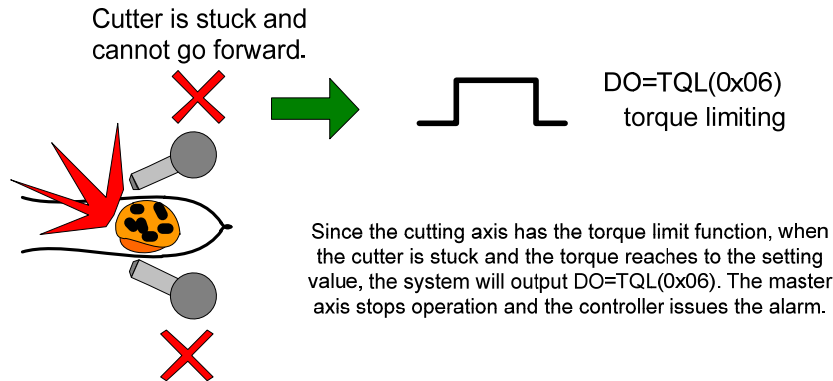

Diagram 3.6.12 Use the torque limit to protect the mechanism

3.6.3.3 Design of E-cam curve

Types of flying shear curve

A variety of flying shear curves is offered by ASDA-A2. See diagram 3.6.13. There are three kinds at the moment. One is to build the curve which has no synchronous zone by PC software. The other one is to build the curve which has synchronous zone and remains at 51 degrees by PC software or macro command. The last one is to build an adjustable curve that has synchronous zone but can only be done by macro command. The advantage of building the flying shear curve in servo drive is that when the cutting length changes, users only need to setup the relevant parameter on HMI interface. After issuing the macro command, the curve is built. This is a great design for multi-process recipes machine. The definition of the calculation in synchronous zone and cutting length proportion will be elaborated later.

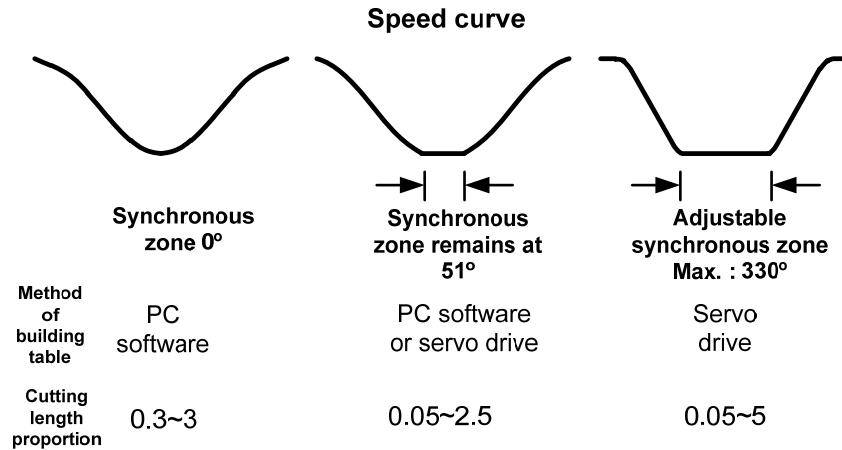

Diagram 3.6.13 Camshaft curve

Meaning and calculation of synchronous zone

The synchronous zone on flying shear curve is the sealing length of wrapping paper, which is the arc length of cutting action. (If the cutter is not wide enough, the cutter width and arc length of cutting action can be regarded as the same distance) During the cutting process, when it travels to the synchronous zone which is the position the cutter starts to seal, if the cutting speed does not equal to the film feeding speed, the packing film will be lengthen or squeezed. That proves that the synchronous zone is vital to flying shear application and has to be accurate. The calculation is shown in diagram 3.6.14.

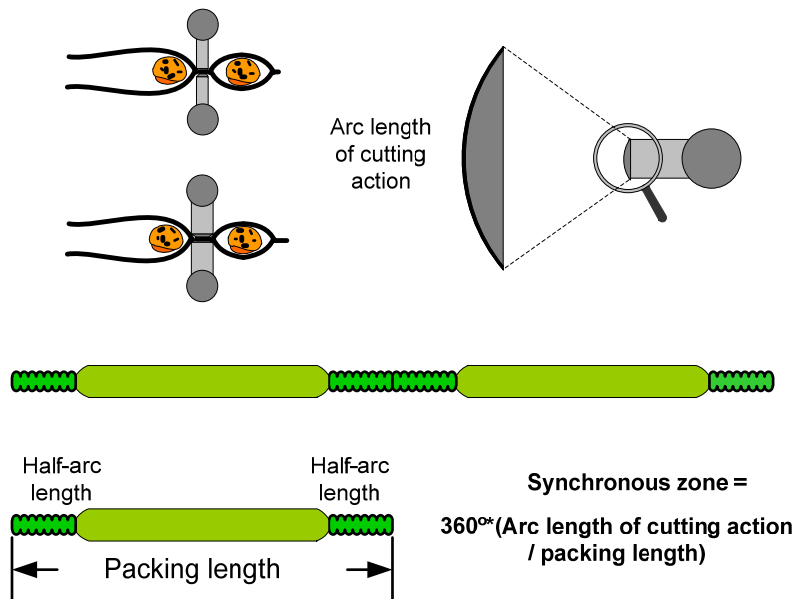

Diagram 3.6.14 Calculation of synchronous zone

Limit of cutting length

Diagram 3.6.13 indicates three kinds of cutting length proportion. The so called cutting length proportion represents the ratio of the wrapping length to the distance the cutter travels, see diagram 3.6.15. In diagram 3.6.13, synchronous zone remains at 51° degrees and the allowable cutting length proportion is 0.05 ~ 2.5 when using software to create the E-cam curve. When the cutting length is close to the minimum value, 0.05, the system will accelerate / decelerate dramatically during flying shear operation. As the result, it easily reaches the limit (The limit of motor operation). Thus, designing the mechanism should avoid the extreme condition during machine operation.

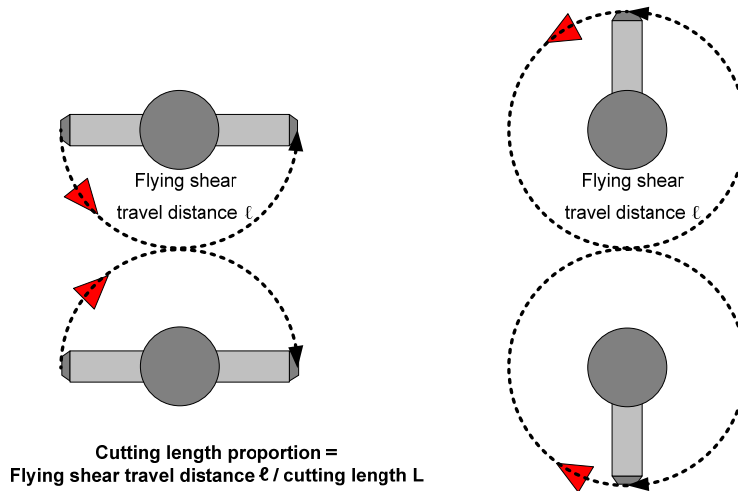

Diagram 3.6.15 Cutting length proportion

If the desired cutting length is 2.5 times greater than the cutting length proportion. Use parameter P5-92 (lead pulse) could make the cutter immobile. So it can cut as long as the user desired. See diagram 3.6.16.

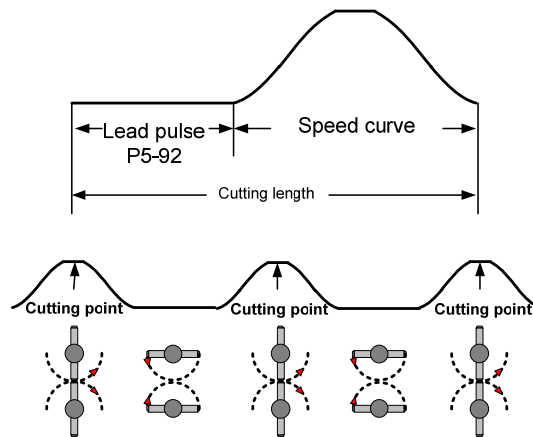

Diagram 3.6.16 Use lead pulse to lengthen the cutting length

Cutting speed compensation

While cutting, the cutting speed will be faster or slower than the film feeding speed base on some specific requirement. When the cutting speed is slower than the speed of synchronous zone, the film will be squeezed. If the cutting is faster, then it will lengthen the film. It is easy to do speed compensation by ASDA-A2. See diagram 3.6.17.

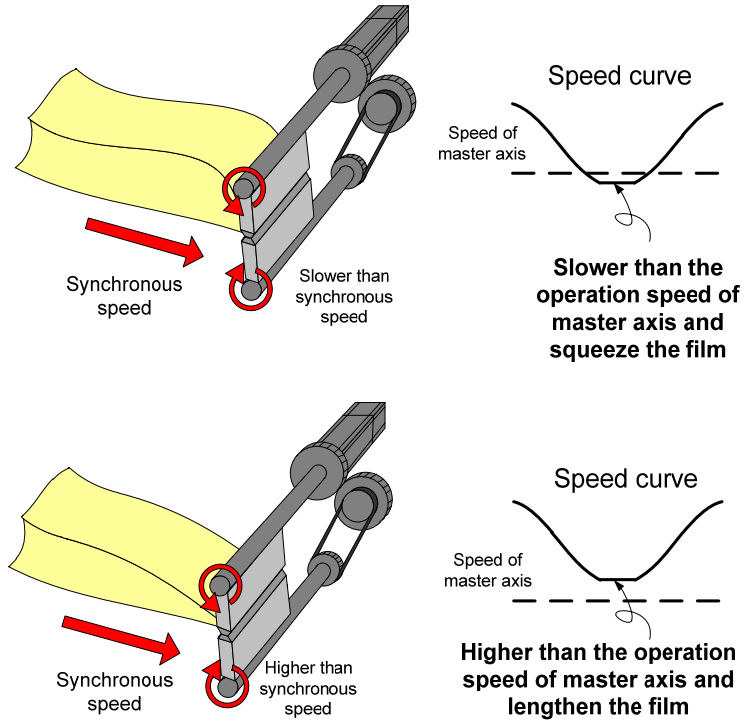

Diagram 3.6.17 Compensation of synchronous speed



Delta Products Corporation

Industrial Automation Business Group

5101 Davis Drive, RTP NC 27709

T: 919 767 3913

